

Original installation and operation manual

CLEARPOINT®

Coalescence filter
Activated carbon filter
Dust filter

- | | | | |
|--------|--------|--------|--------|
| > S040 | > S075 | > M018 | > M025 |
| > S050 | > M010 | > M020 | > M027 |
| > S055 | > M012 | > M022 | > M030 |
| | > M015 | > M023 | > M032 |

■ Table of contents

- 1. Notes about the documentation5**
 - 1.1 Contact5
 - 1.2 Information about this installation and operation manual.....5
 - 1.3 Other applicable documents.....6
- 2. Safety.....7**
 - 2.1 Use.....7
 - 2.1.1 Intended use7
 - 2.1.2 Reasonably foreseeable inappropriate use.....8
 - 2.2 Responsibility of the operating company8
 - 2.3 Target group and personnel9
 - 2.4 Explanation of the symbols used.....10
 - 2.5 Safety instructions and warning notices11
 - 2.5.1 Basic safety instructions.....11
 - 2.5.2 Safe operation.....11
 - 2.5.3 Sudden escape of pressurised fluids12
 - 2.5.4 Transport and storage.....12
 - 2.5.5 Installation.....13
 - 2.5.6 Maintenance13
 - 2.5.7 Handling hazardous substances14
 - 2.5.8 Use of spare parts, accessories or materials14
 - 2.6 Warning notices15
- 3. Product information 16**
 - 3.1 Product description16
 - 3.2 Product overview17
 - 3.3 Product identification18
 - 3.4 Function description20
 - 3.4.1 Condensate discharge through float drain22
 - 3.4.2 Automatic condensate discharge.....23
 - 3.5 Product marking.....23
 - 3.5.1 Maintenance label for filter element replacement23
 - 3.5.2 Type plate.....24
 - 3.5.3 Adhesive filter element label.....25
 - 3.6 Scope of delivery26
- 4. Technical data 27**
 - 4.1 Operating parameters27
 - 4.2 Materials30
 - 4.3 Performance data.....30
 - 4.3.1 Filter elements for coalescence filters and dust filters30
 - 4.3.2 Filter elements for activated carbon filters31
 - 4.4 Dimensions.....32
 - 4.5 Installation conditions34

5. Transport and storage.....	35
5.1 Warning notices	35
5.2 Transport.....	35
5.3 Storage.....	35
6. Installation	36
6.1 Warning notices	36
6.2 Preparatory tasks	37
6.3 Positioning the filter.....	38
6.4 Assembly work.....	39
6.5 Installing accessories	39
6.6 Final steps.....	39
7. Start-up procedure.....	40
7.1 Warning notices	40
7.2 Start-up steps.....	41
8. Maintenance	42
8.1 Warning notices	42
8.2 Maintenance schedule.....	42
8.3 Maintenance work	43
8.3.1 Cleaning.....	43
8.3.1.1 Warning notices.....	43
8.3.1.2 Cleaning work	43
8.3.2 Replace the float drain.....	44
8.3.3 Replacement of the filter element.....	48
8.3.4 Visual inspection.....	52
9. Shut-down procedure	53
9.1 Warning notices	53
9.2 Shutdown steps.....	53
10. Disassembly	55
10.1 Warning notices	55
10.2 Disassembly steps	55
11. Disposal.....	57
11.1 Warning notices	57
11.2 Disposal of operating and auxiliary materials	57
11.3 Disposal of components	57
12. Spare parts and accessories.....	58
12.1 Spare parts	58
12.2 Accessories.....	59

■ Table of contents

13. Troubleshooting.....	61
14. Appendices.....	62
14.1 Manufacturer Declaration	62
14.2 Declaration of Conformity	64

1. Notes about the documentation

This documentation contains all the necessary steps for use of the product and the accessories.

1.1 Contact

Manufacturer	Customer service and tools
BEKO TECHNOLOGIES GmbH Im Taubental 7 41468 Neuss Phone: +49 2131 988-1000 info@beko-technologies.com www.beko-technologies.com	BEKO TECHNOLOGIES GmbH Im Taubental 7 41468 Neuss Phone: +49 2131 988-1000 service-eu@beko-technologies.com www.beko-technologies.com

INFORMATION	Country-specific manufacturer representatives
	You can contact the country-specific manufacturer's representative via the address listed in the address section on the rear cover or by using the contact form on the manufacturer's website.

1.2 Information about this installation and operation manual

INFORMATION	Copyright protection
	The contents of the installation and operation manual in the form of text, figures, illustrations, photographs, technical drawings, diagrams and other representations are protected by the copyright of the manufacturer. The distribution as well as the duplication of this document, the exploitation and the communication of its contents are prohibited unless expressly authorised.

Publication date	Revision	Version	Reason for change	Scope of change
16 December 2024	00	00	Technical and editorial changes	New document

The installation and operation manual, hereinafter referred to as the manual, must always be kept close to the product and be in a permanently legible condition.

The manual must be handed over along with the product if it is sold or passed on.

NOTE	Follow the instructions given in the manual
	This manual contains all the basic information required for safe operation of the product and must be read before any actions are performed. Otherwise personal and material hazards as well as malfunction and device failure are possible.

1.3 Other applicable documents

This manual goes over all the steps required in order to install and operate **CLEARPOINT®** filters.

More detailed information about the installation and operation of the accessories is contained in the following installation and operation manuals:

- **BEKOMAT® 20 / 20 FM**
- **BEKOMAT® 31 / 32 / 33**
- **CLEARPOINT®** differential pressure gauge
- **CLEARPOINT®** oil indicator
- **CLEARPOINT®** filter replacement instruction leaflet

2. Safety

2.1 Use

2.1.1 Intended use

The various intended uses for the coalescence filters, activated carbon filters and dust filters, hereafter also referred to as the “filter” or “product,” are described below:

CLEARPOINT® 3eco coalescence filters are used to filter liquid and solid components from gas mixtures in pressurised systems.

CLEARPOINT® activated carbon filters are used to separate oil vapours and odorants from gas mixtures in pressurised systems.

CLEARPOINT® dust filters are used to separate particles in pressurised systems.

Any use of this system other than the use described in this manual is hereby deemed to be non-intended and can cause a hazard for the safety of people and the environment.

The following must be observed in order to ensure that the filters are used as intended:

- Read and follow the manual.
- Only use the product and accessories within the operating parameters given in the technical data and the agreed delivery conditions.
- Only operate the product and accessories with media which are free of caustic, aggressive, corrosive, toxic, flammable, oxidising or inorganic components. In cases of doubt an analysis must be carried out.
- Only use the product and accessories in areas which are free of toxic and corrosive chemicals and gases.
- Only use the product and accessories within the piping system designed for the technical data with appropriate connections, pipe diameters and assembly clearance.
- Only use the product and accessories outside potentially explosive atmospheres.
- Only use the product and accessories away from direct solar radiation and heat sources as well as areas subject to frost.
- Combine the product and the accessories only with the recommended manufacturer products and components indicated in this manual.
- Adhere to the prescribed maintenance schedule.

Applies exclusively to activated carbon filters and dust filters:

- Use the product and accessories exclusively with pre-dried fluids. Use preliminary filtration and water separation.

Before using the product and the accessories, the operating company must make sure that all conditions and prerequisites for intended use are given.

The product and the accessories have been exclusively designed for stationary use in a commercial or industrial area. All of the assembly, installation, operation, maintenance, disassembly and disposal work described may only be performed by qualified skilled technical personnel.

2.1.2 Reasonably foreseeable inappropriate use

Reasonably foreseeable inappropriate use is deemed to have occurred if the product or the accessories are used in any other way than that described in the section “Intended use”. Reasonably foreseeable inappropriate use includes the use of the product or the accessories in a manner not intended by the manufacturer or supplier but which may result from foreseeable human behaviour.

Reasonably foreseeable inappropriate use includes:

- The execution of any kind of modification, in particular constructive and process-technology related interventions.
- The suspension, bridging or non-application of existing or recommended safety equipment.

This list is not exhaustive as not all possible inappropriate use can be foreseen in advance. If the operating company is aware of any inappropriate use of the product or accessories which are not listed here, the manufacturer must be informed immediately.

2.2 Responsibility of the operating company

The responsible operating company must ensure the following to prevent accidents, incidents and adverse effects on the environment:

- Before all actions, check to ensure that the manual available does in fact belong to the product.
- The product and the accessories are used, serviced and repaired in accordance with the intended use.
- The product and accessories are only used with the recommended and fully operable safety equipment.
- All assembly, installation and maintenance work must be carried out exclusively by qualified skilled technical personnel.
- Personnel have the necessary personal protective equipment available and also use this equipment.
- Suitable technical safety measures are taken so that the permissible operating parameters are adhered to.
- Keep all safety symbols and the type plate on the product and accessories in a legible state. Replace damaged and illegible markings immediately.

2.3 Target group and personnel

This manual addresses the personnel listed below who are involved with work on the product or the accessories.

INFORMATION	Personnel requirements
	<ul style="list-style-type: none"> • Minors are strictly prohibited from working with and on the product and its accessories. • The personnel may not execute any actions on the product or the accessories when they are under the influence of drugs, medications, alcohol or other substances that may impair their consciousness.

Operating personnel

Operating personnel are persons who are able to operate the product and the accessories safely on the basis of knowledge of the manual and instruction at the product and accessories. Operating personnel can recognise possible malfunctions and dangerous situations independently and arrange for corresponding measures.

Skilled technical personnel - transport and storage

Skilled technical personnel - transport and storage are people who, due to their training, professional experience and qualifications, have all the necessary skills to safely carry out and direct all actions relating to the transport and storage of the product, to independently identify potentially hazardous situations and to take measures to avert danger.

The skills required include, in particular, experience operating hoists, forklifts and lifting equipment and familiarity with locally applicable laws, standards and guidelines relating to transport and storage.

Skilled technical personnel - pressure equipment and systems

Skilled technical personnel specialising in pressure equipment and systems consists of people who, due to their training, professional experience and qualifications, have all the necessary skills to safely carry out and direct all actions relating to pressurised fluids and systems, to independently identify potentially hazardous situations, and to implement appropriate measures to avert any danger.









The skills required include, in particular, experience using measuring equipment and control equipment, as well as familiarity with locally applicable laws, standards and regulations for pressurised systems.

Skilled technical personnel - product servicing

Skilled technical personnel - product servicing are people who have the skills and qualifications stated in all the skilled personnel definitions named above. Skilled technical personnel - product servicing must have documented proof of training and authorisation for all work on the product.

2.4 Explanation of the symbols used

The symbols used below indicate safety-relevant and important information which must be adhered to when handling the product and to ensure safe and optimum operation.

Symbol	Description / explanation
	General hazard symbol (danger, warning, caution)
	Pressurised system
	Read and follow the installation and operation manual
	General instruction symbol
	Wear safety footwear
	Use protective gloves (cut-proof and liquid-resistant)
	Wear hearing protection
	Wear safety goggles with side shields
	General information

2.5 Safety instructions and warning notices

This section provides an overview of all the important safety aspects for personal protection as well as for the safe and problem-free operation of the product and accessories.

The following sections list the dangers posed by this product and the accessories even with intended use. To minimise the risk of personal injury and damage to property and to avoid dangerous situations, observe the safety instructions listed and adhere to the warning notices in the other sections of this manual.

Basic warning notices and the necessary qualifications of skilled technical personnel are always listed at the beginning of the section in the “Warning notices” section.

Warning notices related to specific actions are printed directly before potentially hazardous procedures or sequences of actions.

Failure to observe safety instructions and warning notices can result not only in personal injury, but also in malfunctions, device failure and damage to property.

2.5.1 Basic safety instructions

- Before starting work, refer to the technical documentation for the entire system and observe the overall operating instructions.
- Carry out a risk assessment before starting work on site (last minute risk assessment).
- Use suitable personal protective equipment for all work.
- Set up a safety area around the working area during all installation, maintenance and repair work.
- Use existing system-specific protection procedures (e.g., LOTO procedure) in order to safely de-energise and isolate the system or system sections.

2.5.2 Safe operation

The following actions may result in serious injury or death:

- Start-up and operation of the product and accessories outside the permissible limit values and operating parameters
- Unauthorised interference and unauthorised modifications of the product and accessories

To guarantee the safe operation of the product and accessories, observe the following:

- Observe the limits and operating parameters specified on the type plate and in the manual.
- Check whether the permissible operating parameters have been changed or restricted by the use of accessories.
- Observe the requirements regarding installation location and ambient conditions.
- Adhere to the maintenance intervals.

2.5.3 Sudden escape of pressurised fluids

The following situations may result in serious injury or death:

- Contact with fast or suddenly escaping fluids
- Bursting system parts
- Whipping of pressurised hoses and pipes

For the safe handling of pressurised systems, observe the following:

- Observe the following safety rules during all work:
 1. Shut down the system or system section.
 2. Secure the system or system section against restarting.
 3. Reduce the pressure in the system or all system sections to the ambient pressure.
e.g. by slowly releasing the pressure in a controlled manner via relief valves
 4. Lock out and tag out the system or system section so that it cannot be pressurised again.
- Check the pressurised system or system section for safety, contamination and possible damage.
- Before pressurisation, check all system connections for leak tightness and tighten if necessary.
- Make absolutely sure to charge the system or system section with pressure slowly.
- Avoid pressure blows and high differential pressures.
- Compensate any vibrations occurring in the pipe network by using vibration dampers.

2.5.4 Transport and storage

Inappropriate transport or storage may result in personal injury or damage to property.

In order to ensure safety during the transport and storage of the product and accessories, observe the following:

- Use personal protective equipment during all work with packaging material.
- Handle packaging, the product and accessories carefully.
- Transport and handle the product and accessories according to the markings on the packaging.
- Use only proper transportation, lifting and lashing equipment that is in proper working order.
- Use only transportation, lifting and lashing equipment that are rated for the total weight of the product.
- Always adhere to the permissible transport and storage parameters.
- Store the product and accessories only outside of areas exposed to direct sunlight and heat sources.

2.5.5 Installation

Inappropriate assembly or electrical installation of the product and accessories may result in personal injury and damage to property as well as impair operation.

For safe assembly and electrical installation, observe the following:

- Install the product, the accessories, and all parts and materials used so that they are not subject to mechanical tension.
- Check all plug-type connections for a correct fit.
- Avoid a stumbling hazard by routing cables and hoses accordingly.
- Avoid mechanical strain on the cables.
- Fix and fasten hoses in such a way that they cannot flap around.
- Install the inlet and drain lines as fixed pipes.

2.5.6 Maintenance

Inappropriate completion of maintenance and repair work may result in serious personal injuries or death.

For safe maintenance and repairs, observe the following:

- Before starting work, depressurise the pressurised product and accessories and secure them against unintentional pressurisation.
- Only use materials approved for the respective application.
- Use only suitable tools that are in proper working order.
- Only use cleaned pipes and hoses that are free of dirt and corrosion.
- Never use abrasive or aggressive cleaning agents or solvents which could damage the outer coating (e.g. markings, type plate, corrosion protection, etc.).
- Never clean the device with hard or pointed implements.
- Use only the specified materials and media for cleaning.
- Observe statutory, local and in-house hygiene regulations.
- Pay attention to order and cleanliness during maintenance and repair work. Prevent contamination from entering the opened product or accessories. Put dismantled components and accessories aside in a safe place immediately after dismantling.
- After completing maintenance and repair work, remove all tools and cleaning agents used, as well as all parts that are no longer needed, from the work area.
- Only dispose of the product and accessories when cleaned and freed of any residue.
- Dispose of all components, parts, operating and auxiliary materials as well as cleaning agents professionally and in accordance with all locally applicable legal requirements and regulations.

2.5.7 Handling hazardous substances

Contact with condensate containing substances which endanger health and the environment can pose a health hazard, causing irritation and/or damage to the eyes, skin and mucous membranes. In addition, contaminated condensate must be prevented from entering the sewage system, bodies of water or the ground.

For the safe handling of contaminated condensate, observe the following:

- Use suitable protective equipment when handling condensate.
- Collect and dispose of any leaking or spilled condensate in accordance with locally applicable legal requirements and regulations.

2.5.8 Use of spare parts, accessories or materials

The use of incorrect spare parts, accessories or materials, as well as auxiliary and operating materials, may result in death or serious injury. Malfunction and device failure as well as material damage can occur.

- Only use undamaged original parts, auxiliary and operating materials which are specified by the manufacturer to complete all work.
- Only use the materials approved for the respective application and suitable tools in proper working order.
- Only use cleaned pipes that are free of dirt and corrosion.
- Only use electric components and materials that comply with locally applicable legal requirements and regulations (standards, directives etc.) for electrical safety.

2.6 Warning notices

Warning notices warn against dangers when handling the product and accessories.

Observe the warning notices in order to avoid personal injury, damage to property and impaired operation.

Elements used in warnings:

SIGNAL WORD	Type and source of danger
 Symbol	Possible consequences if the danger is ignored
	<ul style="list-style-type: none"> Measures to prevent the danger

Signal words:

DANGER	Imminent hazard Consequences of non-compliance: Death or serious personal injury
WARNING	Imminent hazard Consequences of non-compliance: Death or serious personal injury are possible
CAUTION	Potential hazard Consequences of non-compliance: Personal injury is possible
NOTE	Potential damage to property Consequences of non-compliance: Damage to property, malfunction and device failure are possible. No hazard to people or jeopardizing of safe operation.

3. Product information

Properly designing the system with preliminary filtration and drying systems will prevent the accretion of other particles and liquid components on the filter material, enabling the corresponding filter element to optimally fulfil its intended use.

3.1 Product description

CLEARPOINT® filters are used for the filtration applications listed below. Depending on the requirements in question, filter elements can be used with various filtration stages in order to achieve the desired compressed air purity class in conformity with ISO 8573-1.

The condensate that accumulates during filtration can be discharged manually or automatically from the filter.

CLEARPOINT® 3eco coalescence filters are used to filter liquid and solid components from gas mixtures in pressurised systems.

CLEARPOINT® activated carbon filters are used to separate oil vapours and odorants from gas mixtures in pressurised systems. The residual oil content in the corresponding gas mixture can be measured over a prolonged period of time ($t > \text{hundred hours}$) with an oil test indicator.

CLEARPOINT® dust filters are used to separate particles in pressurised systems.

3.2 Product overview

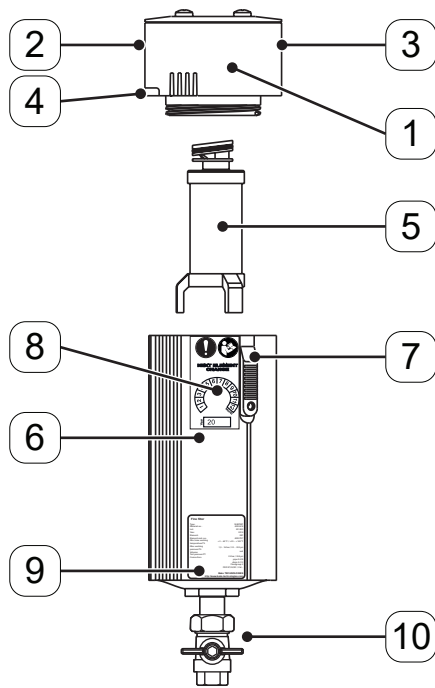

Coalescence filter
Activated carbon filter

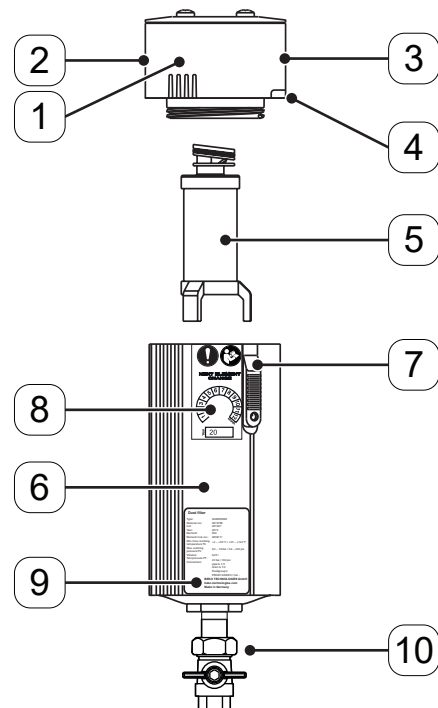

Dust filter

No.	Description / explanation
[1]	Filter head
[2]	Inlet at the filter head
[3]	Outlet at the filter head
[4]	Direction indicator
[5]	Filter element
[6]	Filter housing
[7]	Safety slide with locking screw
[8]	Adhesive maintenance label for filter element replacement
[9]	Type plate
[10]	Manual condensate drain

3.3 Product identification

The abbreviated product designation can be found on the type plate and is made up of numbers and letters. Each element of the abbreviated designation stands for one of the filter’s components. The elements are subdivided into the following categories accordingly:

- [1] = Size: Filter housing
- [2] = Filter elements
- [3] = Upper attachments
- [4] = Lower attachments

The way the product designation works is explained below using “S040FPB” as an example:

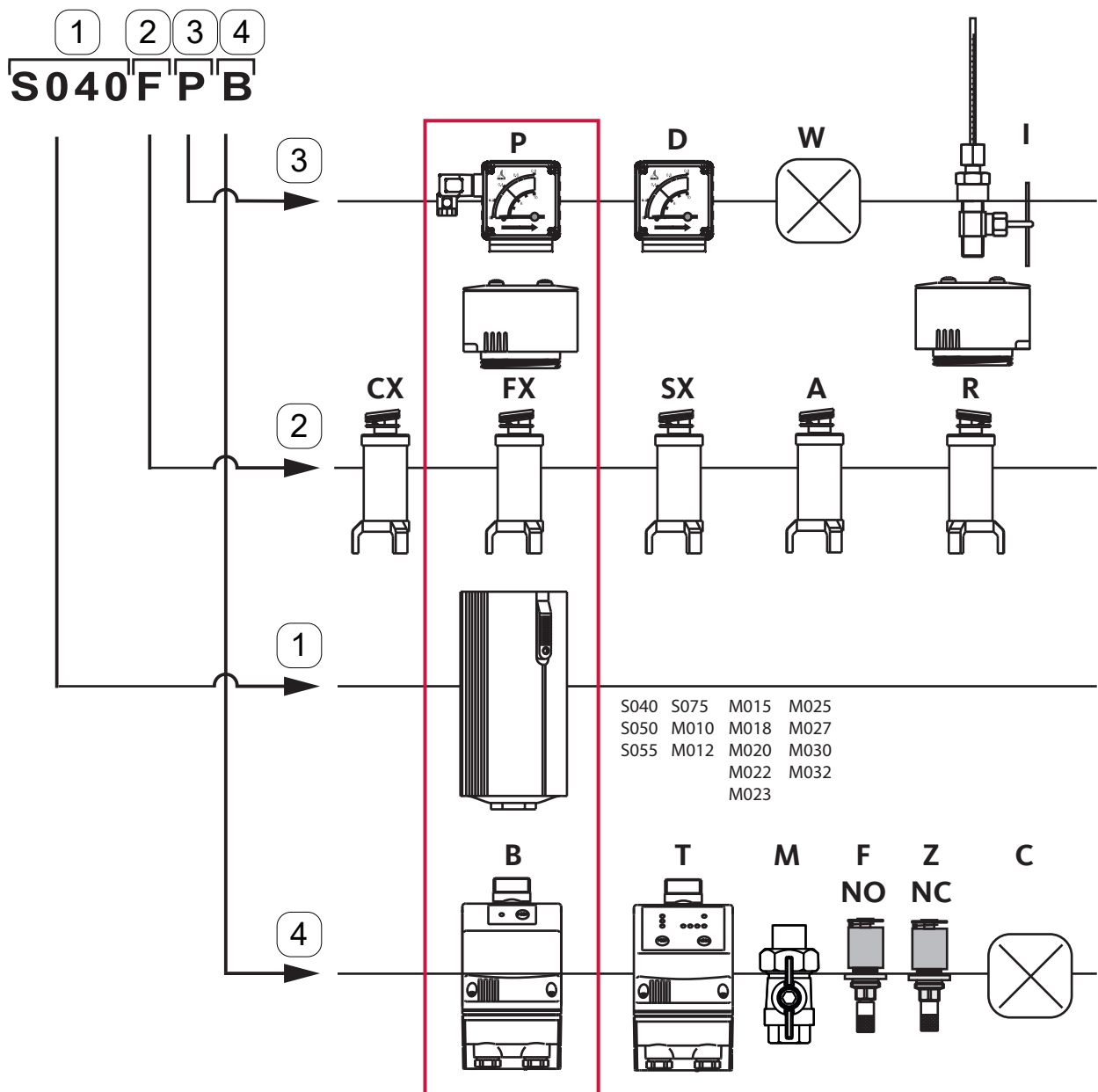

Upper attachments		
No.	Abbreviation	Description / explanation
[3]	P	Differential pressure gauge with dry contact
	D	Differential pressure gauge without dry contact
	W	No indicator
	I	Oil test indicator

Filter elements					
No.	Abbreviation	Description / explanation	99.9% separation rate solid particles [µm]	Residual oil content [mg/m ³]* ¹	Compressed air class in conformity with ISO 8573 - 1
[2]	CX ^{*2}	Coarse filter	2 ... 5	≤ 5	[4: - :4]
	FX ^{*2}	Fine filter	0.5 ... 1	≤ 0.05	[2: - :2]
	SX ^{*2}	Super fine filter	0.1 ... 0.3	≤ 0.005	[1: - :2]
	A	Activated carbon filter	--	≤ 0.003	[- : - :1]

Filter housing			
No.	Model series	Size	Volume l (gal)
[1]	S	040	0.25 (0.07)
	S	050	0.31 (0.08)
	S	055	0.42 (0.11)
	S	075	0.87 (0.23)
	M	010	1.12 (0.3)
	M	012	1.26 (0.33)
	M	015	2.52 (0.67)
	M	018	2.97 (0.78)
	M	020	3.4 (0.9)
	M	022	4.23 (1.12)
	M	023	5.24 (1.38)
	M	025	13.88 (3.67)
	M	027	16.49 (4.36)
	M	030	19.51 (5.15)
M	032	23.24 (6.14)	

*¹ Validation in conformity with ISO 12500-1, approx. inlet concentration of 10 mg/m³ for SX, FX; 30 mg/m³ for CX

*² Dust filters with an identical degree of filtration are abbreviated for coarse filters with RC, fine filters with RF and ultrafine filters with RS.

Lower attachments		
No.	Abbreviation	Description / explanation
[4]	B	BEKOMAT® 20 / 31 / 32 / 33
	T	BEKOMAT® 20 FM
	M	Manual condensate drain
	F	Float drain, open when not pressurised (NO – normally open)
	Z	Float drain, closed when not pressurised (NC - normally closed)
	C	No condensate drain

3.4 Function description

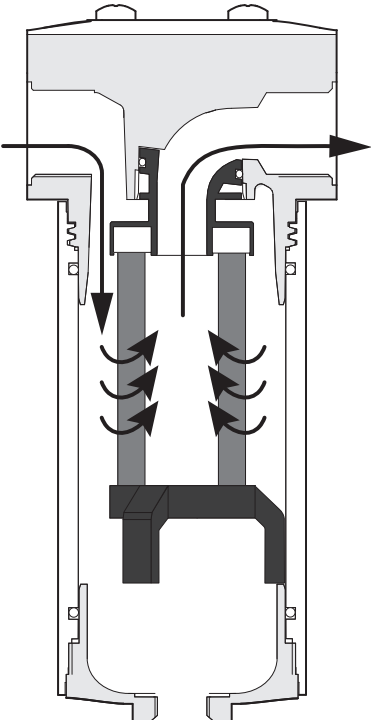
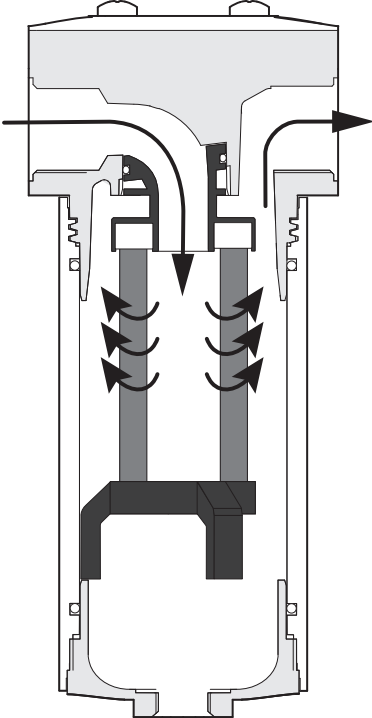

Illustration	Description / explanation
	<p>Dust filter</p> <p>In CLEARPOINT® dust filters, the direction of flow through the filter element is from the outside to the inside. The fluid enters the filter housing and flows from the outside through the filter element and into the inside of the element. The particles are separated in the non-woven filter material.</p> <p>The incoming fluid must be pre-dried so that it will be free of liquid components and the filter material will be able to absorb the particles. If there is no pre-drying, the filter material will be saturated with liquid components and will not be able to absorb particles as a result.</p> <p>The filter’s service life will depend on the size and quantity of particles in the fluid. The filter material’s void volume only has a limited capacity for absorbing particles.</p>

Illustration	Description / explanation
	<p>Coalescence filter</p> <p>In CLEARPOINT® 3eco coalescence filters, the direction of flow through the filter element is from the inside to the outside. The fluid enters the inner area of the filter element and from there flows through the filter element and into the filter housing. During this process, the filter material separates solids such as oil and water aerosols. Meanwhile, gravity causes the liquid components in the outer drainage layer to move downwards, drip down and collect at the bottom of the filter housing. The condensate at the bottom of the housing can then be drained manually or automatically. Over time, particles become deposited in the filter material. This results in an increase in the flow resistance of the filter element and, as a result, in an increase in the differential pressure in the system.</p> <p>Activated carbon filter</p> <p>In CLEARPOINT® activated carbon filters, the direction of flow through the filter element is from the inside to the outside. The fluid enters the inner area of the filter element and from there flows through the filter element and into the filter housing. During this process, oil vapours and odorants are separated by the activated carbon in the filter material.</p> <p>Please note that in order to ensure that the filter works efficiently, particles and aerosols must first be removed with preliminary filtration and the fluid must be pre-dried. The filter material's void volume only has a limited capacity for absorbing particles.</p> <p>Liquid components will reduce this void volume and, as a result, the available absorption capacity for particles and the element's service life. Accordingly, incoming fluid should be pre-dried.</p> <p>The filter's service life will depend on the fluid's load, since the filter material can only absorb a limited amount of hydrocarbons.</p>

3.4.1 Condensate discharge through float drain

INFORMATION	Float drain factory setting
	Both float drain versions come set for “automatic discharge” from the factory. The knurled screw is screwed downwards as far as it will go.

Two different float drains are used to discharge the condensate:

- Open when not pressurised [NO]: The float drain will open at an operating pressure ≤ 0.5 bar(g) (7.25 psi(g)).
- Closed when not pressurised [NC]: The float drain will be closed at an operating pressure of 0 bar(g) (0 psi(g)).

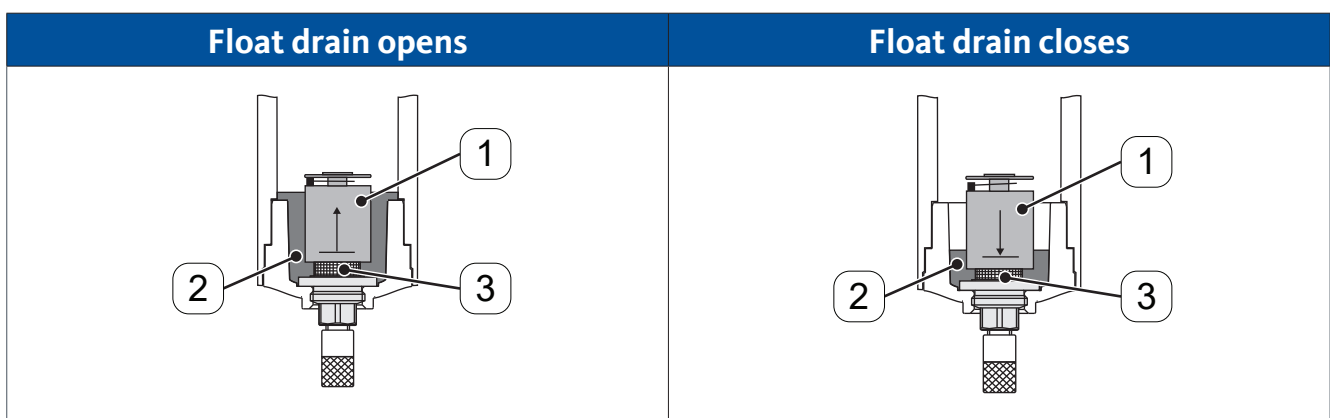

The float drains are mechanical automatic condensate drains with an operating mechanism that is triggered by the buoyant force of a float body **[1]**. When the condensate **[2]** in the container rises to a certain level, the buoyant force of the float body **[1]** opens the outlet channel **[3]** for the condensate. The float body closes again when the condensate **[2]** drops below a certain level. A small amount of condensate remains in the container.

To depressurise the filter for maintenance work, the float drain can be brought to the “mechanically open” position. Screw the knurled screw anti-clockwise upwards as far as it will go so that there is no visible gap above the knurled screw anymore.



3.4.2 Automatic condensate discharge

For level-controlled condensate discharge, you can install a **BEKOMAT®** at the condensate outlet.

For more information, consult the **BEKOMAT®** installation and operation manual (please refer to “1.3 Other applicable documents” on page 6).

3.5 Product marking

3.5.1 Maintenance label for filter element replacement

The next due filter element replacement date is entered on this adhesive label. To do so, mark the corresponding month **[1]** and write down the corresponding year **[2]** with a permanent marker. An adhesive maintenance label is included with every filter element.

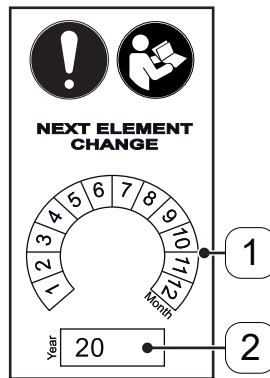

No.	Description / explanation
[1]	Specification of month for next filter element replacement
[2]	Specification of year for next filter element replacement

3.5.2 Type plate

The type plate, which contains the identification and operating parameters for the filter, is found on the housing. Please provide the corresponding information for product identification when contacting the manufacturer or supplier.

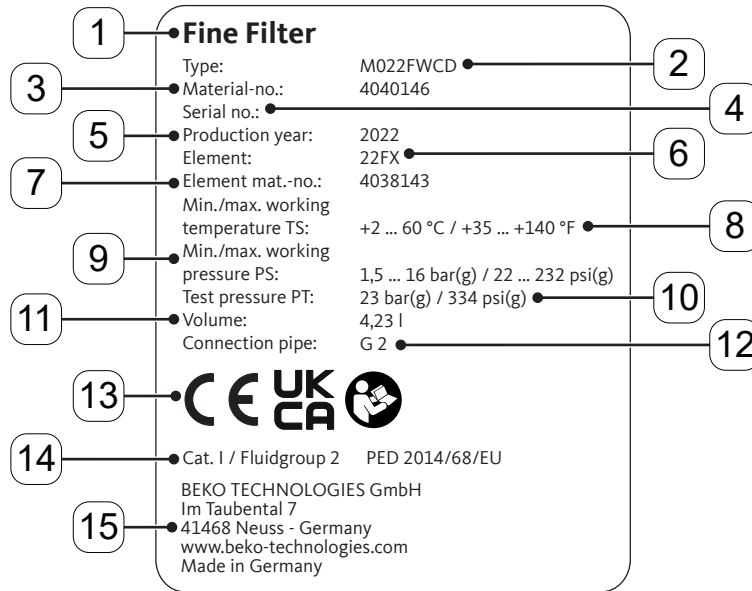



Sample coalescence filter type plate

No.	Description / explanation
[1]	Filter designation
[2]	Product name
[3]	Material number
[4]	Serial number
[5]	Year of production
[6]	Filter element designation
[7]	Filter element part number
[8]	Minimum / maximum operating temperature range
[9]	Maximum operating pressure range
[10]	Test pressure
[11]	Filter housing volume
[12]	Inlet and outlet threaded connections
[13]	Conformity markings
[14]	Fluid group and category in accordance with Pressure Equipment Directive 2014/68/EU
[15]	Manufacturer address

3.5.3 Adhesive filter element label

There are different filter elements for different applications and degrees of filtration.

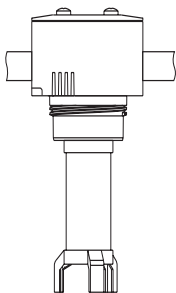
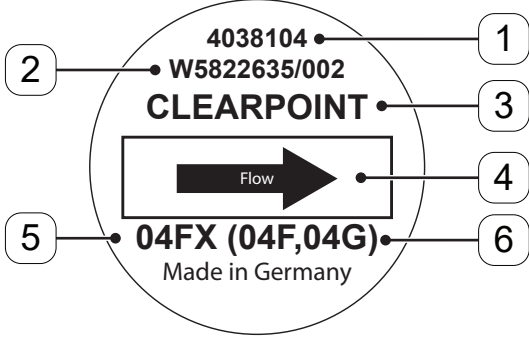
The filter element can be identified on the basis of an adhesive label on the base of the filter element.

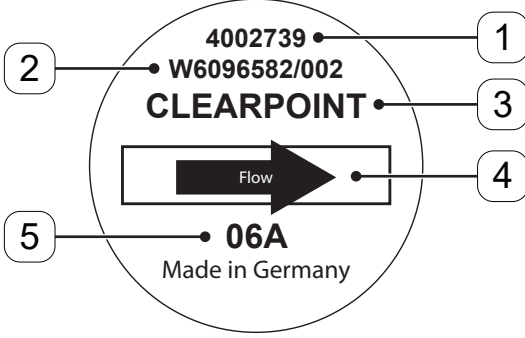
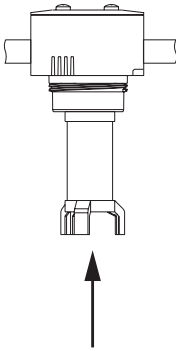
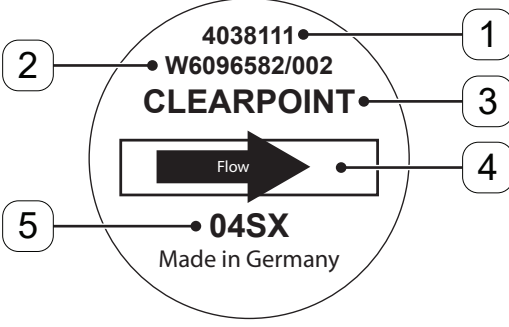
		View of filter element bottom
Coalescence filter		
Activated carbon filter		
Dust filter		

No.	Description / explanation
[1]	Material number
[2]	Lot number
[3]	Product group
[4]	Indication of the filter element's direction of flow
[5]	Filter element designation (e.g., 04FX: filter size 04, ultrafine filter) <ul style="list-style-type: none"> Filter element size (e.g., 04, 06) Filter element type (e.g., coarse filter – CX, fine filter – FX, ultrafine filter – SX, activated carbon filter – A)
[6]	Filter element designation for preceding model in parentheses (e.g., 04F, 04G)

3.6 Scope of delivery

The following table shows the scope of delivery of the filter:

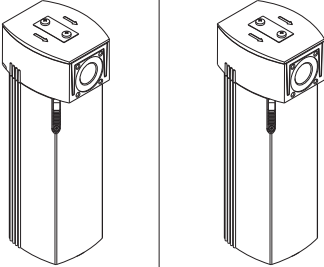
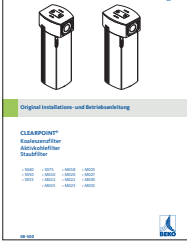
Illustration	Description / explanation
	<p>Filter (coalescence filter, activated carbon filter, or dust filter)</p>
	<p>Original installation and operation manual</p>

4. Technical data

4.1 Operating parameters

Abbreviated product code	Accessories	Minimum / maximum operating pressure	Minimum / maximum operating temperature
F	With float drain AM10-NO	1.5 ... 16 bar(g) 21.8 ... 232 psi(g)	+2 ... +60 °C +35 ... +140 °F
Z	With float drain AM10-NC	0.3 ... 16 bar(g) 4.4 ... 232 psi(g)	+2 ... +60 °C +35 ... +140 °F
C	Without drain	1.5 ... 16 bar(g) 21.8 ... 232 psi(g)	+2 ... +60 °C +35 ... +140 °F
M	With manual drain	0.3 ... 16 bar(g) 4.4 ... 232 psi(g)	+2 ... +60 °C +35 ... +140 °F
	Condensate outlet with blind plug	0.3 ... 16 bar(g) 4.4 ... 232 psi(g)	+2 ... +60 °C +35 ... +140 °F
B / T	With BEKOMAT ®	0.8 ... 16 bar(g) 11.6 ... 232 psi(g)	+2 ... +60 °C +35 ... +140 °F
P / D	With differential pressure gauge	0.3 ... 16 bar(g) 4.4 ... 232 psi(g)	+2 ... +50 °C +35 ... +122 °F
W	Without differential pressure gauge	0.3 ... 16 bar(g) 4.4 ... 232 psi(g)	+2 ... +60 °C +35 ... +140 °F

CLEARPOINT®	S040	S050	S055	S075	M010	M012	M015	M018	
Threaded connection	3/8 1/2*1	1/2	1/2	3/4 1*1	1	1	1 1/2 2*1	1 1/2 2*1	
Volumetric flow rate, energy-optimized, m ³ /h (ft ³ /min) ^{*2}	35 (21)	65 (38)	100 (59)	150 (88)	200 (118)	250 (147)	320 (188)	420 (247)	
Differential pressure in mbar (psi), saturated	C	~50 (~ 0.73)							
	F	80 (1.16)	115 (1.67)	150 (2.18)	185 (2.68)	120 (1.74)	165 (2.39)	80 (1.16)	90 (1.31)
	S	100 (1.45)	125 (1.81)	170 (2.47)	120 (1.74)	135 (1.96)	180 (2.61)	100 (1.45)	110 (1.60)
Volumetric flow rate, performance-oriented, m ³ /h (ft ³ /min) ^{*2}	46 (27)	85 (50)	130 (77)	195 (115)	260 (153)	325 (191)	415 (244)	545 (321)	
Differential pressure in mbar (psi), saturated	C	~ 70 (1.02)							
	F	105 (1.52)	160 (2.32)	230 (3.34)	150 (2.18)	180 (2.61)	230 (3.34)	110 (1.60)	125 (1.81)
	S	125 (1.81)	170 (2.47)	255 (3.70)	175 (2.54)	200 (2.90)	260 (3.77)	130 (1.89)	150 (2.18)
Category according to PED 2014/68/EU	-	-	-	-	-	-	-	-	
Load test in conformity with DIN EN 13445-3	10,000 load cycles - 1 load cycle corresponds to a pressure fluctuation ≥ 3.2 bar (46.41 psi) at 16 bar(g) (232 psi(g))								
Medium	Fluid from fluid group 2 in accordance with PED 2014/68/EU, free of aggressive and corrosive components								
Weight kg (lbs)	0.75 (1.65)	0.85 (1.87)	1.2 (2.65)	1.7 (3.75)	2.1 (4.63)	2.2 (4.85)	4.1 (9.04)	4.5 (9.92)	
Volume l (gal)	0.25 (0.07)	0.31 (0.08)	0.42 (0.11)	0.87 (0.23)	1.12 (0.3)	1.26 (0.33)	2.52 (0.67)	2.97 (0.78)	

*1 Optionally available

*2 Volumetric flow rate at 7 bar(g) (102 psi(g)) relative to +20 °C (+68 °F) and 1 bar(a) (14.5 psi(a)); reference values in conformity with DIN 7183

CLEARPOINT®	M020	M022	M023	M025	M027	M030	M032	
Threaded connection	2	2	2	2 1/2 3*1	2 1/2 3*1	3	3	
Volumetric flow rate, energy-optimized, m ³ /h (ft ³ /min) ^{*2}	600 (353)	780 (459)	1020 (600)	1300 (765)	1620 (954)	1940 (1142)	2400 (1412)	
Differential pressure in mbar (psi), saturated	C	~50 (~ 0.73)						
	F	120 (1.74)	150 (2.18)	200 (2.90)	100 (1.45)	115 (1.67)	120 (1.74)	145 (2.10)
	S	140 (2.03)	170 (2.47)	210 (3.05)	125 (1.81)	130 (1.89)	140 (2.03)	165 (2.39)
Volumetric flow rate, performance-oriented, m ³ /h (ft ³ /min) ^{*2}	780 (459)	1015 (597)	1325 (780)	1690 (995)	2100 (1236)	2520 (1483)	3120 (1836)	
Differential pressure in mbar (psi), saturated	C	~ 70 (1.02)						
	F	180 (2.61)	210 (3.05)	290 (4.21)	140 (2.03)	155 (2.25)	180 (2.61)	220 (3.19)
	S	210 (3.05)	250 (3.63)	320 (4.64)	170 (2.47)	185 (2.68)	210 (3.05)	250 (3.63)
Category according to PED 2014/68/EU	I	I	I	II	II	II	II	
Load test in conformity with DIN EN 13445-3	10,000 load cycles - 1 load cycle corresponds to a pressure fluctuation ≥ 3.2 bar (46.41 psi) at 16 bar(g) (232 psi(g))							
Medium	Fluid from fluid group 2 in accordance with PED 2014/68/EU, free of aggressive and corrosive components							
Weight kg (lbs)	5.1 (11.24)	6.1 (13.45)	7.1 (15.65)	19.9 (43.87)	22.6 (49.82)	25.9 (57.1)	29.9 (65.92)	
Volume l (gal)	3.40 (0.9)	4.23 (1.12)	5.24 (1.4)	13.9 (3.67)	16.5 (4.36)	19.5 (5.15)	23.2 (6.13)	

*1 Optionally available

*2 Volumetric flow rate at 7 bar(g) (102 psi(g)) relative to +20 °C and 1 bar(a) (14.5 psi(a)); reference values in conformity with DIN 7183

4.2 Materials

Component	Material
Filter head, filter housing	Aluminium, coated
Housing cover	Polyamide
Housing base	Aluminium, coated
M5 screws	Steel, galvanised
Slide	Zinc
O-rings	Standard: NBR Oil-free: FKM
Float drain	Stainless steel Plastic Brass NBR
Manual condensate drain	Brass, nickel-plated
Wall bracket	Steel, galvanised
Adhesive label	PVC and polyacrylate
Filter elements	Plastics, stainless steel, and borosilicate fibres

4.3 Performance data

4.3.1 Filter elements for coalescence filters and dust filters

The performance data for the filter elements is based on validation in conformity with ISO 12500-1 and ISO 12500-3.

Type	Description / explanation	Solid particles (µm)	Aerosol content (mg/m ³)	
			Inlet	Outlet
C	Coarse filter	Separation rate 99.9 % for particles 2.0 ...5.0	30	5
F	Fine filter	Separation rate 99.9 % for particles 0.5 ...1.0	10	0.05
S	Super fine filter	Separation rate 99.99 % for particles 0.1 ... 0.3	10	0.005

Filter element service life in coalescence filters and dust filters			
Parameter	Coalescence filter	Dust filter	Filter element service life
Differential pressure	≥ 0.4 bar (5.8 psi)		Replace the filter element when the differential pressure is ≥ 0.4 bar(g) (5.8 psi(g)) or after one year of use at the latest.

4.3.2 Filter elements for activated carbon filters

The filter elements for activated carbon filters were validated based on ISO 12500-2 using measuring equipment that conforms to the standard and with a load of 10 mg/m³.

Based on empirical data, a residual oil content value corresponding to class 1 in conformity with ISO 8573-1 can be achieved with upstream filtration and fluid drying at the outlet.

Filter element service life in activated carbon filters		
Parameter Reference conditions	Activated carbon filter	Filter element service life
Differential pressure	≥ 0.4 bar / 5.8 psi	Replace the filter element when the differential pressure is ≥ 0.4 bar(g) (5.8 psi(g)) or after six months of use at the latest.
Percentage of activated carbon with absorption capacity in the filter element	< 15%	<p>With the reference conditions listed in the first column, a service life of approx. 2,000 operating hours is achievable.</p> <ul style="list-style-type: none"> Absorbing 100% of the hydrocarbons in the fluid with the activated carbon is not possible: The absorption capacity for hydrocarbons depends not only on the activated carbon properties (raw materials, grain size, pore size, etc.), but also, and above all, on the molecular structure and polarity of the gas fractions being absorbed.
Compressed air temperature	+20 °C (+68 °F)	
Actual proportion of hydrocarbons	0.01 mg/m ³	
Compressed air degree of dryness (relative humidity)	Maximum 30%	

4.4 Dimensions

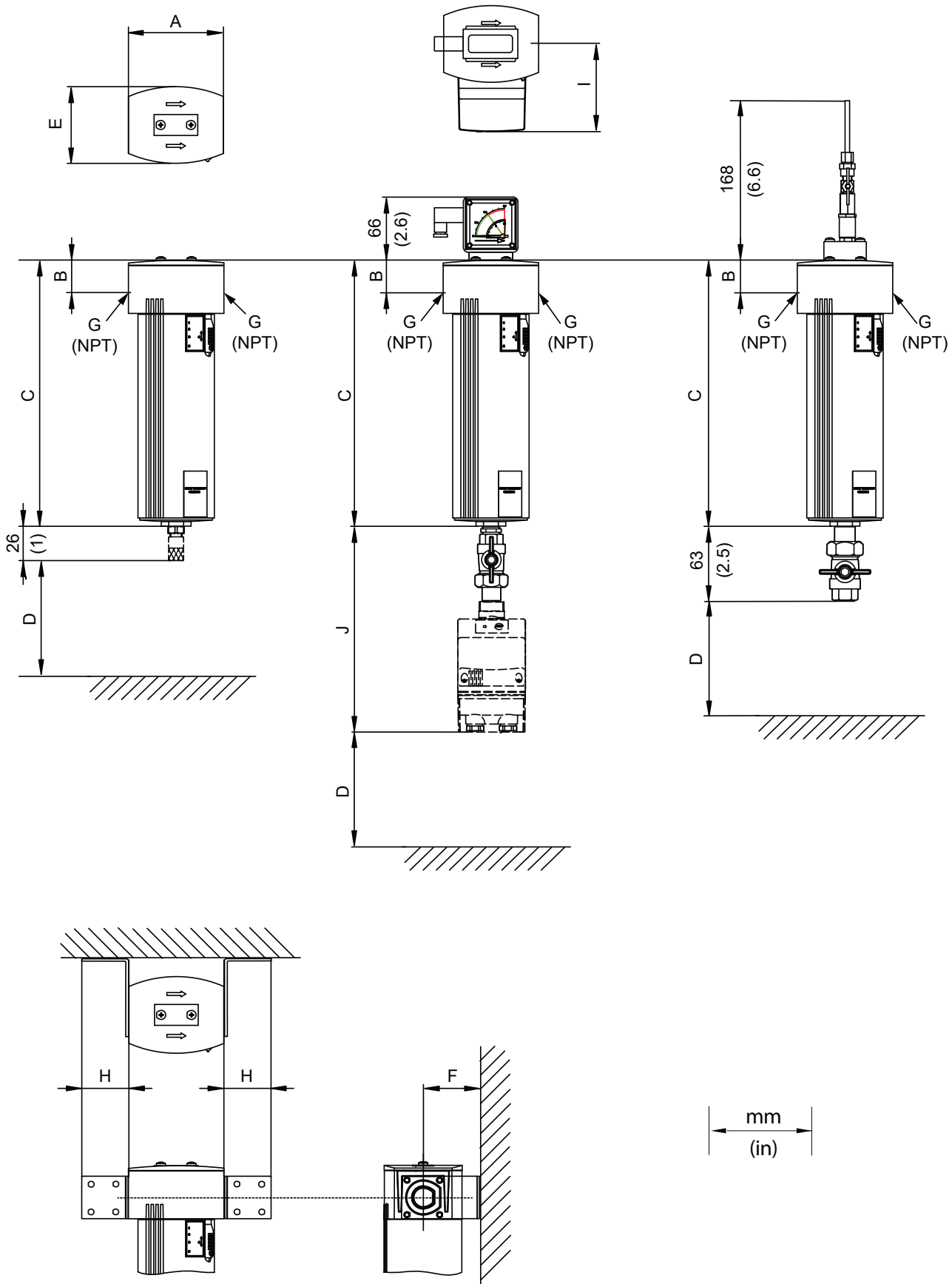

Filter (Size)	A	B	C	D	E	F	H	Filter element
	mm (in)							
S040	75 (2.95)	28 (1.10)	182 (7.17)	150 (5.91)	61 (2.40)	64.5 (2.54)	39.5 (1.56)	04
S050	75 (2.95)	28 (1.10)	212 (8.35)	150 (5.91)	61 (2.40)	64.5 (2.54)	39.5 (1.56)	05
S055	75 (2.95)	28 (1.10)	267 (10.51)	150 (5.91)	61 (2.40)	64.5 (2.54)	39.5 (1.56)	06
S075	100 (3.94)	33 (1.29)	282 (11.10)	150 (5.91)	81 (3.18)	63 (2.48)	45 (1.77)	06
M010	100 (3.94)	33 (1.29)	352 (13.86)	150 (5.91)	81 (3.18)	63 (2.48)	45 (1.77)	10
M012	100 (3.94)	33 (1.29)	387 (15.24)	150 (5.91)	81 (3.18)	63 (2.48)	45 (1.77)	12
M015	146 (5.75)	47 (1.85)	363 (14.29)	200 (7.87)	119 (4.68)	78.5 (3.09)	60 (2.36)	15
M018	146 (5.75)	47 (1.85)	416 (16.39)	200 (7.87)	119 (4.68)	78.5 (3.09)	60 (2.36)	18
M020	146 (5.75)	47 (1.85)	466 (18.35)	200 (7.87)	119 (4.68)	78.5 (3.09)	60 (2.36)	20
M022	146 (5.75)	47 (1.85)	563 (22.17)	200 (5.91)	119 (4.68)	78.5 (3.09)	60 (2.36)	22
M023	146 (5.75)	47 (1.85)	681 (26.81)	200 (7.87)	119 (4.68)	78.5 (3.09)	60 (2.36)	23
M025	260 (10.24)	77 (3.03)	670 (26.38)	300 (11.81)	201 (7.91)	130 (5.12)	120 (4.72)	25
M027	260 (10.24)	77 (3.03)	774 (30.47)	300 (11.81)	201 (7.91)	130 (5.12)	120 (4.72)	27
M030	260 (10.24)	77 (3.03)	894 (35.20)	300 (11.81)	201 (7.91)	130 (5.12)	120 (4.72)	30
M032	260 (10.24)	77 (3.03)	1042 (41.02)	300 (11.81)	201 (7.91)	130 (5.12)	120 (4.72)	32

Accessories	I	J
BEKOMAT® 20 / 20FM connection set	93 (3.67)	211 (8.31)
BEKOMAT® 31 connection set	135 (5.32)	186 (7.32)
BEKOMAT® 32 connection set	150 (5.91)	188 (7.4)
BEKOMAT® 33 connection set	170 (6.69)	218 (8.58)

4.5 Installation conditions

- The place of installation must be within a building used for industrial purposes.
- Install the product at an adequate distance from potential sources of vibration and pulsation (e.g., machinery).
- There must be enough space at the place of installation for all work to be performed with and on the product (e.g., installation, maintenance, retrofitting accessories).
- Install the product in a clean and dry area outside of areas exposed to direct sunlight, frost, sources of heat and/or potential sources of fire.
- Install the product outside traffic routes and install bumper guards around the product.
- Install a manually operated shut-off valve at the inlet and outlet of the **CLEARPOINT®** in order to be able to carry out maintenance work.
- In order to ensure that fluid will be continuously supplied even during maintenance work, the manufacturer recommends installing a bypass line **[3]** with fluid treatment equipment and shut-off valves **[1, 2]**, as well as a condensate discharge line that can be separated from the manual condensate drain.
- The pipes must be able to bear the additional weight of the filter. Additional mounts must be installed if necessary.

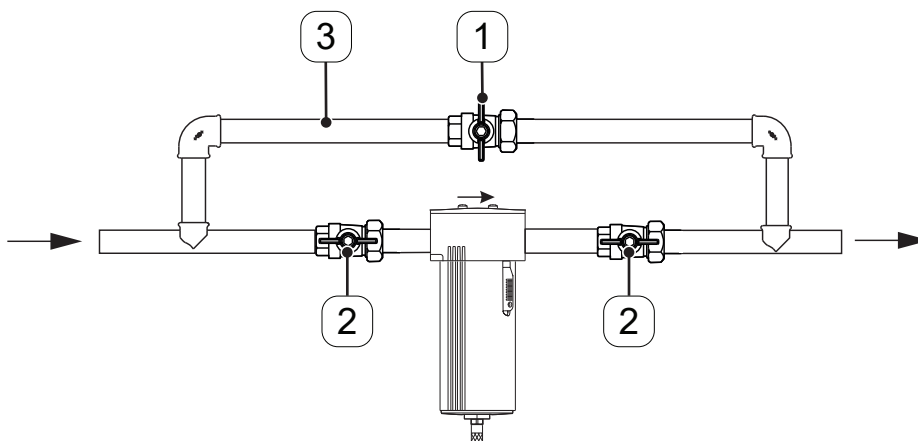



5. Transport and storage

Personnel

Skilled technical personnel - transport and storage
(see section “2.3 Target group and personnel” on page 9)

5.1 Warning notices

CAUTION	Inappropriate transport or storage
	<p>Inappropriate transport or storage may result in personal injury.</p> <ul style="list-style-type: none"> • Use personal protective equipment during all work with packaging material. • Use only proper transportation, lifting and lashing equipment that is in proper working order. • Use only transportation, lifting and lashing equipment that are rated for the total weight of the product. • Always adhere to the permissible transport and storage parameters.
NOTE	Handling packaging material
	<p>Inappropriate disposal of packaging materials can cause environmental damage.</p> <ul style="list-style-type: none"> • Dispose of the packaging material in accordance with the applicable legal requirements and provisions of the country and place of use.

5.2 Transport

- Transport and handle the product and accessories according to the markings on the packaging.
- Pack all parts using suitable shockproof material.
- Handle packaging, the product and accessories carefully.

5.3 Storage



- Store the product and accessories only outside of areas exposed to direct sunlight and heat sources.

6. Installation

Personnel

Skilled technical personnel - pressure equipment and systems
(see section “2.3 Target group and personnel” on page 9)

6.1 Warning notices

<p>DANGER</p>	<p>Sudden escape of pressurised fluids</p>
	<p>There is a danger of death or serious personal injury resulting from contact with fast or suddenly escaping fluids or through bursting system parts.</p> <ul style="list-style-type: none"> • Before starting work, depressurise the pressurised system and secure it against unintentional pressurisation. • Assemble all pipes and hoses free of mechanical stress.
<p>NOTE</p>	<p>Mechanical damage</p>
	<p>Connecting more than three filters will result on excessive strain on the wall bracket and can lead to the deformation of the wall bracket and connected components.</p> <ul style="list-style-type: none"> • Use one wall bracket for securing a maximum of three connected CLEARPOINT® filters.

6.2 Preparatory tasks

Prerequisites		
Tools	Material	Protective equipment
<ul style="list-style-type: none"> Screwdriver - cross-head size PZ1 	<ul style="list-style-type: none"> Additional installation and operation manuals for the accessories used Sealing materials such as e.g. PTFE tape (EN 837-2) Leak detector spray 	

Preparatory tasks	
1.	Remove the plugs from the following threads: <ul style="list-style-type: none"> Inlet and outlet on the filter head Condensate drain on the filter base
2.	Depressurise the piping system or relevant pipe section.
3.	Pipes must be free of contamination and corrosion. <ul style="list-style-type: none"> → Check the pipe thread for damage. → Replace faulty pipes immediately.
4.	Implement the condensate drain in such a way that no fluid or condensate can escape into the filter's surroundings. Convey the condensate being discharged to a legally compliant treatment system.

6.3 Positioning the filter

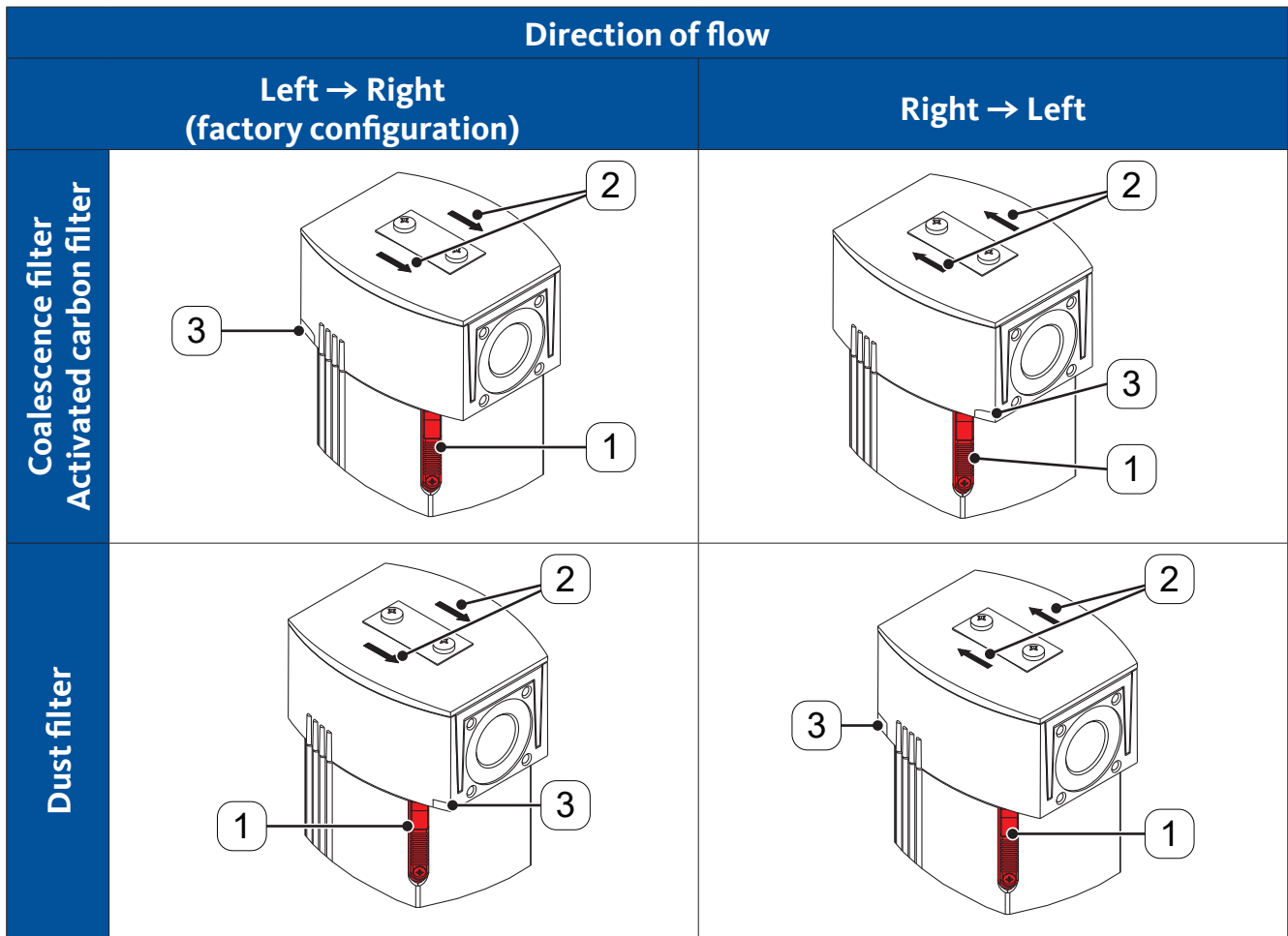

Make sure that the direction of flow matches the pipe's direction of flow and position the filter in the pipe accordingly:

- The filter head and the filter housing have a double-start trapezoidal thread.
- You can adjust the filter's direction of flow to match the pipe's direction of flow by turning the filter head 180°.
- The direction of flow is indicated with arrows [2] and a raised marking [3] on the filter head.
- Position the safety slide [1] on the operator side (front side) in such a way that it is accessible.

The direction indicator marks the fluid inlet from the operator's view of the filter as described below.

Type of filter	Direction of flow	Position Direction indicator	Position Safety slide
Coalescence filter	From left to right	Left	Right
Activated carbon filter		Left	Right
Dust filter		Right	Right
Coalescence filter	From right to left	Right	Right
Activated carbon filter		Right	Right
Dust filter		Left	Right

6.4 Assembly work

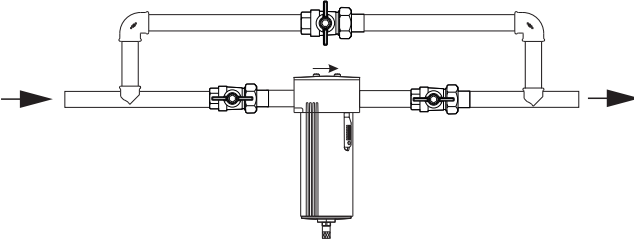
Illustration	Description / explanation
	<ol style="list-style-type: none"> 1. Apply the sealing material e.g., Teflon tape (EN 837-2), to the pipe ends. 2. Screw the pipe thread into the filter inlet until the connection is firm and leak-tight. 3. Screw the pipe thread into the filter outlet until the connection is firm and leak-tight.

6.5 Installing accessories

Accessory installation procedures are described in the corresponding applicable documents; refer to “1.3 Other applicable documents” on page 6.

6.6 Final steps

Final steps	
1.	The filter housing is screwed into the filter head correctly.
2.	The safety slide has been slid all the way up.
3.	The locking screw has been tightened.
4.	<p>Carry out a leak test after finishing all installation work.</p> <ul style="list-style-type: none"> → Fix any leaks you find and seal the corresponding thread again. → If you hear any whistling, this means that the safety slide is not closed correctly. Slide the safety slide all the way up and tighten the locking screw.

7. Start-up procedure

Personnel

Skilled technical personnel - pressure equipment and systems and skilled technical personnel - electrical
(refer to section “2.3 Target group and personnel” on page 9)

7.1 Warning notices

DANGER	Sudden escape of pressurised fluids
	<p>There is a danger of death or serious personal injury resulting from contact with fast or suddenly escaping fluids or through bursting system parts.</p>
	<ul style="list-style-type: none"> • Before pressurisation, check all system connections for leak tightness and tighten if necessary. • Slowly pressurise the system.

7.2 Start-up steps

Prerequisites		
Tools	Material	Protective equipment
<ul style="list-style-type: none"> No tool necessary. 	<ul style="list-style-type: none"> No materials necessary. 	<ul style="list-style-type: none"> No protective equipment required.

Preparatory tasks	
1.	The filter has been fully installed.

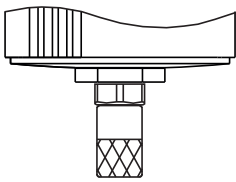
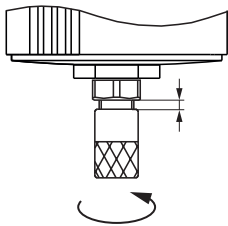
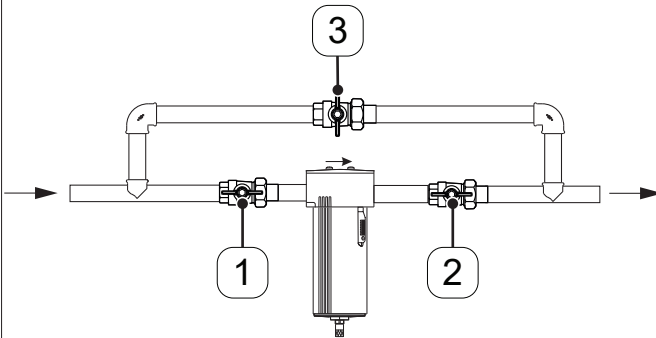
Start-up steps		
Illustration		Description / explanation
Mechanically open	Automatic discharge	
		<ol style="list-style-type: none"> Turn the knurled screw on the float drain from the MECHANICALLY OPEN position to the AUTOMATIC DISCHARGE position. <ul style="list-style-type: none"> → Unscrew the knurled screw clockwise until you can see a gap above the knurled screw.
		<ol style="list-style-type: none"> Slowly open the shut-off valve [1] on the inlet side. Slowly open the shut-off valve [2] on the outlet side. Close the shut-off valve for the bypass line [3], if any.

8. Maintenance

Personnel
Skilled technical personnel - product servicing (see section “2.3 Target group and personnel” on page 9)

8.1 Warning notices

DANGER	Sudden escape of pressurised fluids
	There is a danger of death or serious personal injury resulting from contact with fast or suddenly escaping fluids or through bursting system parts.
	<ul style="list-style-type: none"> Before starting work, depressurise the pressurised system and secure it against unintentional pressurisation.



8.2 Maintenance schedule

Maintenance work	Interval
Cleaning work	At regular intervals, depending on the degree of contamination
Visual inspection	Weekly
Replace the float drain	Annually
Replacement of the filter element	Refer to section “4.3 Performance data” on page 30
Leakage test	At the end of all assembly and maintenance work on the product
Checking the inside of the filter housing for damage and corrosion	Every time the filter element is replaced

8.3 Maintenance work

8.3.1 Cleaning

8.3.1.1 Warning notices

CAUTION	Personal injury due to inappropriate use of cleaning media
	Inappropriate use of cleaning media may result in minor injuries and damage to health.
	<ul style="list-style-type: none"> • Use personal protective equipment. • Use cleaning media in accordance with the manufacturer's instructions.
NOTE	Observe local hygiene regulations
	In addition to the cleaning instructions listed, any regionally applicable or company-specific hygiene regulations must be observed.

8.3.1.2 Cleaning work

Prerequisites		
Tools	Material	Protective equipment
<ul style="list-style-type: none"> • No tool necessary. 	<ul style="list-style-type: none"> • Mild cleaning agent • Cotton or disposable cloth 	

Cleaning work	
1.	Spray cleaning agent onto an unused cotton cloth or disposable tissue until it is damp (not wet).
2.	Wipe down the entire surface of the component.
3.	Finally, dry the component with a dry cloth or let it air-dry.

8.3.2 Replace the float drain

Prerequisites		
Tools	Material	Protective equipment
<ul style="list-style-type: none"> Screwdriver - cross-head size PZ 	<ul style="list-style-type: none"> New float drain with enclosed adapter (width across flats: 13 mm) 	

Preparatory tasks	
1.	Open the shut-off valve on the bypass line, if any.

Replacing the float drain		Description / explanation
		<ol style="list-style-type: none"> Close the shut-off valves [1] upstream and downstream of the filter or the relevant system section.
Automatic discharge 	Mechanically open 	<ol style="list-style-type: none"> Relieve the pressure in the filter. <ul style="list-style-type: none"> → Turn the knurled screw on the float drain from the AUTOMATIC DISCHARGE position to the MECHANICALLY OPEN position. Screw in the knurled screw all the way anticlockwise.
		<ol style="list-style-type: none"> Loosen the locking screw on the safety slide. Push the safety slide downwards.

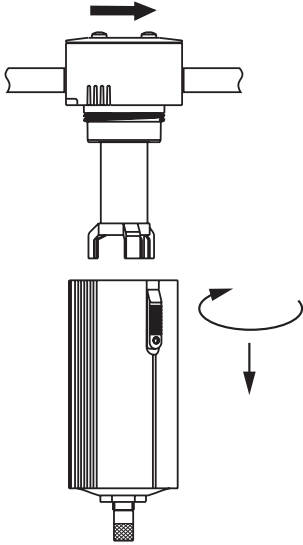
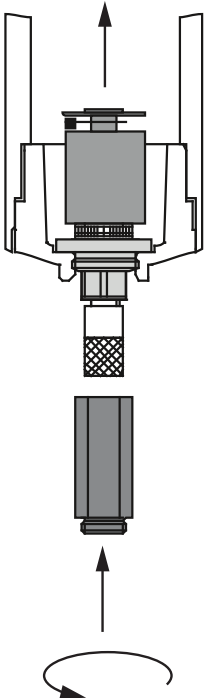
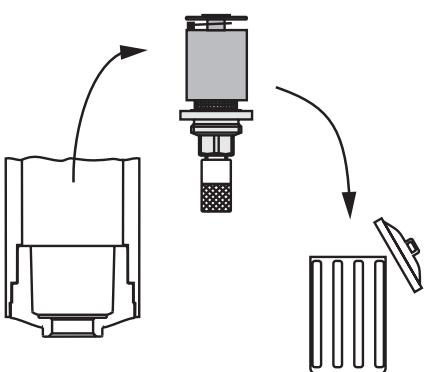
Replacing the float drain	
Illustration	Description / explanation
	<ol style="list-style-type: none"> 5. Unscrew the filter housing. 6. Remove the filter housing downwards.
	<ol style="list-style-type: none"> 7. Use the adapter to unscrew the float drain anti-clockwise. 8. Remove the float drain by lifting it out of the filter housing.
	<ol style="list-style-type: none"> 9. Dispose of the float drain properly and in compliance with all locally applicable legal requirements and regulations. <ul style="list-style-type: none"> → For more information, see “11. Disposal” on page 57.

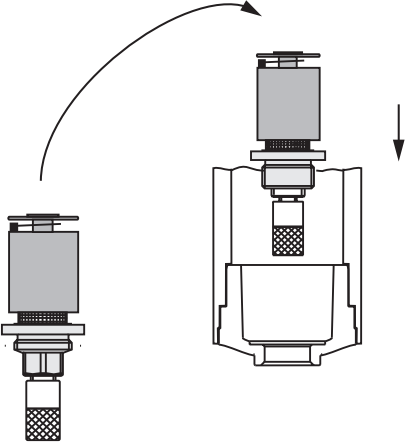
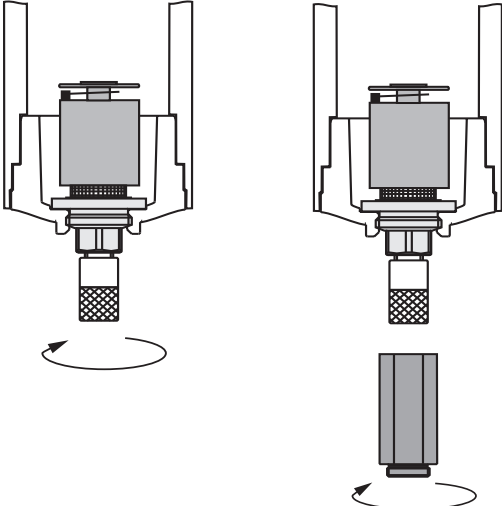
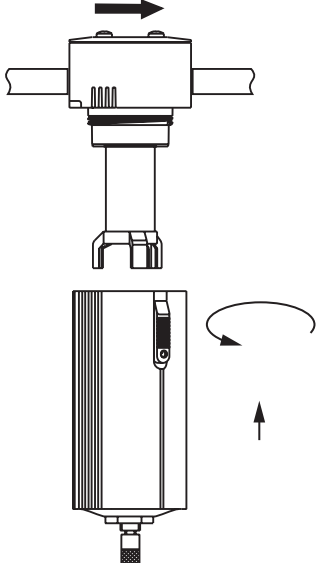
Replacing the float drain	
Illustration	Description / explanation
	<p>10. Insert the new float drain into the filter housing.</p>
	<p>11. Screw the float drain into the filter housing clockwise by hand. 12. Screw the float drain into place with the adapter.</p>
	<p>13. Screw the filter housing into place on the filter head. → Position the safety slide in such a way that it will be accessible on the operator side after installation.</p>

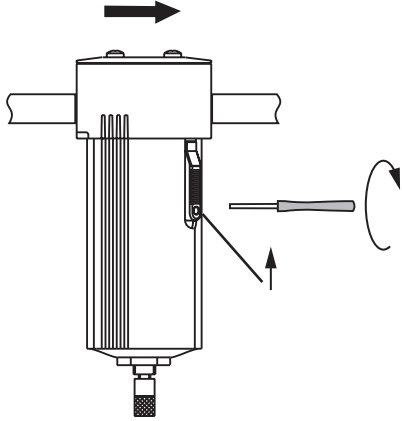
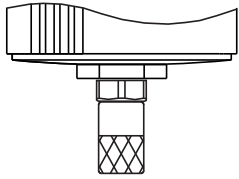
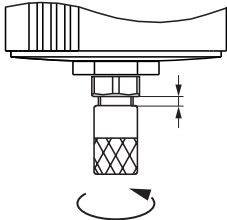
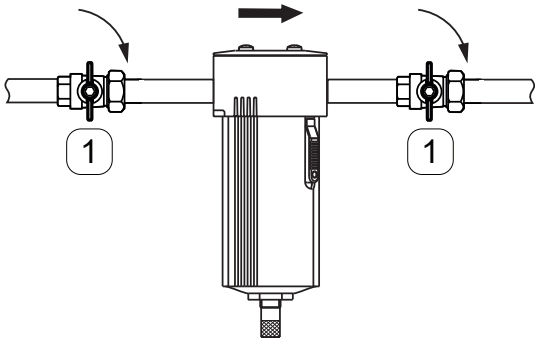
Replacing the float drain	
Illustration	Description / explanation
	<p>14. Push the safety slide upwards.</p> <p>15. Tighten the locking screw on the safety slide.</p>
Mechanically open	Automatic discharge
	
<p>16. Turn the knurled screw on the float drain from the MECHANICALLY OPEN position to the AUTOMATIC DISCHARGE position.</p> <p>→ Unscrew the knurled screw clockwise until you can see a gap above the knurled screw.</p>	
	<p>17. Slowly open the shut-off valves [1] upstream and downstream of the filter or the relevant system section.</p>

Final steps	
1.	Slowly close the shut-off valve for the bypass line, if any.
2.	During pressurisation, check all system connections for leak tightness and tighten if necessary.
3.	Slowly pressurise the system.

8.3.3 Replacement of the filter element

Prerequisites		
Tools	Material	Protective equipment
<ul style="list-style-type: none"> Screwdriver - cross-head size PZ1 	<ul style="list-style-type: none"> New filter element 	

Preparatory tasks	
1.	Open the shut-off valve on the bypass line, if any.

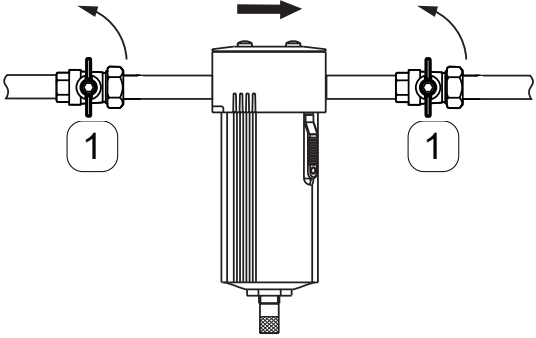
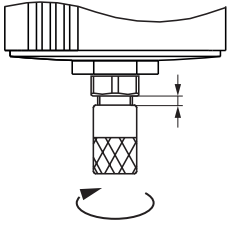
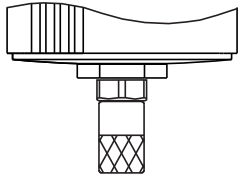
Replacement of the filter element		Description / explanation
Illustration		
		<p>1. Close the shut-off valves [1] upstream and downstream of the filter or the relevant system section.</p>
<p>Automatic discharge</p> 	<p>Mechanically open</p> 	<p>2. Relieve the pressure in the filter.</p> <ul style="list-style-type: none"> When using a float drain: <ul style="list-style-type: none"> → Turn the knurled screw on the float drain from the AUTOMATIC DISCHARGE position to the MECHANICALLY OPEN position. Screw in the knurled screw all the way anticlockwise. When using a BEKOMAT®: <ul style="list-style-type: none"> → Briefly press the TEST button multiple times. When using a manual condensate drain: <ul style="list-style-type: none"> → Carefully open the manual condensate drain.

Replacement of the filter element

Illustration	Description / explanation
	<p>When using a BEKOMAT® or a manual condensate drain:</p> <ol style="list-style-type: none"> 3. Loosen the union nut [1]. 4. Pull the BEKOMAT® or the manual condensate drain downwards.
	<ol style="list-style-type: none"> 5. Loosen the locking screw on the safety slide. 6. Push the safety slide downwards.
	<ol style="list-style-type: none"> 7. Unscrew the filter housing. 8. Remove the filter housing downwards.

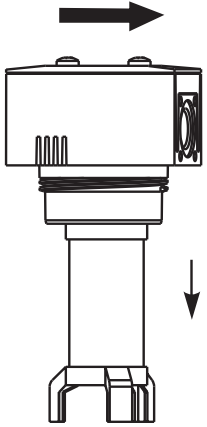
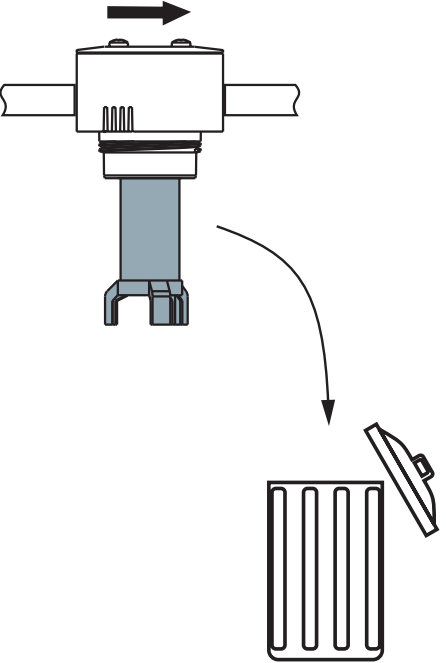
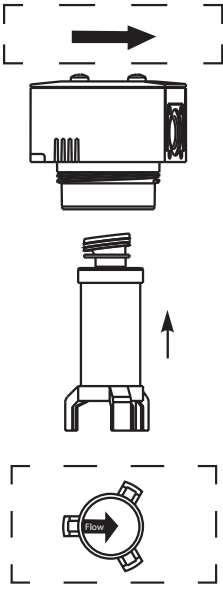
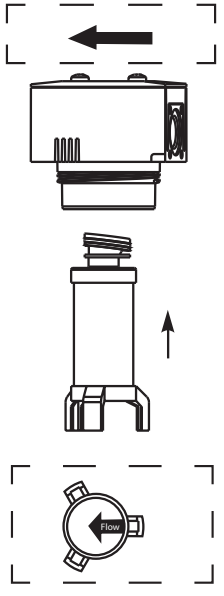
Replacement of the filter element	
Illustration	Description / explanation
	<p>9. Pull the used filter element down and out of the filter head.</p>
	<p>10. Dispose of the filter element properly and in compliance with all locally applicable regulations.</p> <p>→ For more information, see “11. Disposal” on page 57.</p>
<div style="display: flex; justify-content: space-around;"> <div style="text-align: center;">  <p>Activated carbon filter Coalescence filter</p> </div> <div style="text-align: center;">  <p>Dust filter</p> </div> </div>	<p>11. Insert the new filter element into the filter head. The marking at the bottom of the filter element indicates the element’s direction of flow.</p> <p>→ In the case of coalescence filters and activated carbon filters, the direction of flow of the pipe and the filter element should match.</p> <p>→ In the case of dust filters, the direction of flow of the filter element should be opposite to the direction of flow of the pipe.</p>

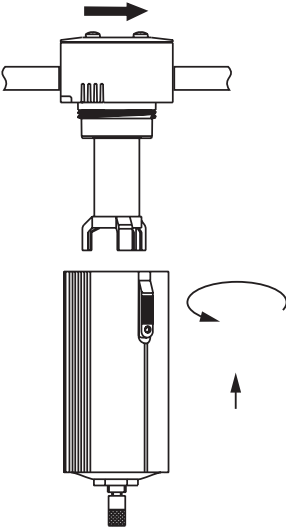
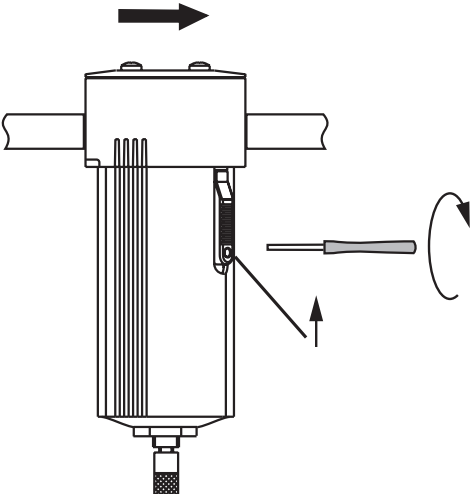
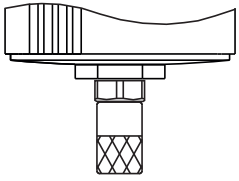
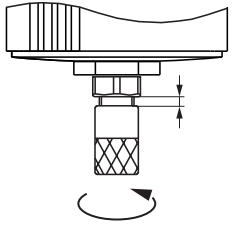
Replacement of the filter element		
Illustration	Description / explanation	
	<p>12. Screw the filter housing onto the filter head. → Make sure that the safety slide is facing the front.</p>	
	<p>13. Push the safety slide upwards. 14. Tighten the locking screw on the safety slide.</p>	
Mechanically open	Automatic discharge	
		<p>15. Turn the knurled screw on the float drain from the MECHANICALLY OPEN position to the AUTOMATIC DISCHARGE position. → Unscrew the knurled screw clockwise until you can see a gap above the knurled screw.</p>

Replacement of the filter element	
Illustration	Description / explanation
	<p>When using a BEKOMAT® or a manual condensate drain:</p> <p>16. Securely tighten the union nut [1] (maximum of 10 Nm).</p> <p>17. Connect the BEKOMAT® or the manual condensate drain.</p>
	<p>18. Slowly open the shut-off valves [1] upstream and downstream of the filter or the relevant system section.</p>

Final steps	
1.	Close the shut-off valve for the bypass line, if any.
2.	During pressurisation, check all system connections for leak tightness and tighten if necessary.
3.	Slowly pressurise the system.

8.3.4 Visual inspection

During the visual inspection of the filter, all components must be inspected for mechanical damage and corrosion. Replace damaged components immediately.

9. Shut-down procedure

Personnel	
Skilled technical personnel - product servicing (see section “2.3 Target group and personnel” on page 9)	

9.1 Warning notices

DANGER	Sudden escape of pressurised fluids
	<p>There is a danger of death or serious personal injury resulting from contact with fast or suddenly escaping fluids or through bursting system parts.</p> <ul style="list-style-type: none"> Before starting work, depressurise the pressurised system and secure it against unintentional pressurisation.

9.2 Shutdown steps

Preparatory tasks	
1.	Open the shut-off valve for the bypass line [3] , if any.

Illustration	Description / explanation
	<ol style="list-style-type: none"> Close the shut-off valves [1] upstream and downstream of the filter or the relevant system section.

Illustration		Description / explanation
Automatic discharge	Mechanically open	<p>2. Relieve the pressure in the filter.</p> <ul style="list-style-type: none"> • When using a float drain: <ul style="list-style-type: none"> → Turn the knurled screw on the float drain from the AUTOMATIC DISCHARGE position to the MECHANICALLY OPEN position. Screw in the knurled screw all the way anticlockwise. • When using a BEKOMAT®: <ul style="list-style-type: none"> → Briefly press the TEST button multiple times. • When using a manual condensate drain: <ul style="list-style-type: none"> → Carefully open the manual condensate drain.
		

10. Disassembly

Personnel

Skilled technical personnel - product servicing (see section “2.3 Target group and personnel” on page 9)

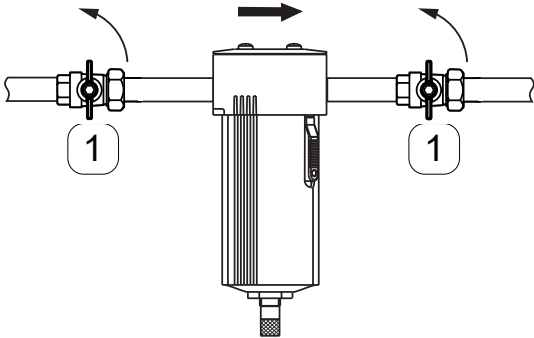
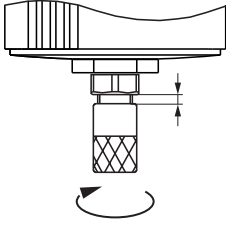
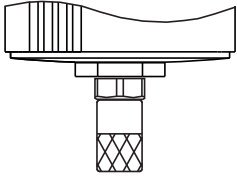
10.1 Warning notices

DANGER	Sudden escape of pressurised fluids
	<p>There is a danger of death or serious personal injury resulting from contact with fast or suddenly escaping fluids or through bursting system parts.</p> <ul style="list-style-type: none"> Before starting work, depressurise the pressurised system and secure it against unintentional pressurisation.

10.2 Disassembly steps

Prerequisites		
Tools	Material	Protective equipment
<ul style="list-style-type: none"> Screwdriver - cross-head size 2.5 mm 	<ul style="list-style-type: none"> No material necessary 	

Preparatory tasks

- The product has been completely removed from service and is depressurised.

Disassembly

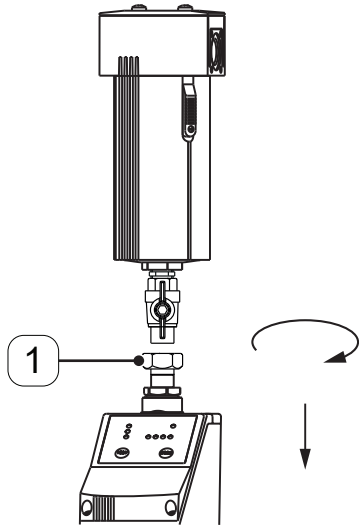
Illustration	Description / explanation
	<p>When using a BEKOMAT® or a manual condensate drain:</p> <ol style="list-style-type: none"> Loosen the union nut [1]. Pull the BEKOMAT® or the manual condensate drain downwards.

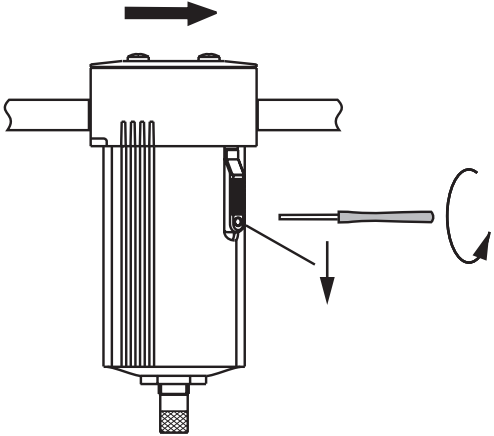
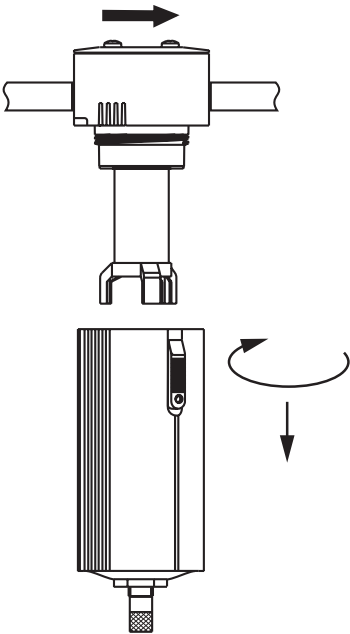
Disassembly	
Illustration	Description / explanation
	<ol style="list-style-type: none">3. Loosen the locking screw on the safety slide.4. Push the safety slide downwards.
	<ol style="list-style-type: none">5. Unscrew the filter housing.6. Remove the filter housing downwards.7. Remove the filter element:8. Remove the filter head from the pipe and seal the pipe ends properly.9. Dispose of the components properly.

11. Disposal

At the end of their useful life the product and the accessories must be sent for disposal e.g. by a specialist company. Materials such as glass, plastics and some chemical compounds are mostly recoverable, reusable or recyclable.

11.1 Warning notices

NOTE	Improper disposal
	<p>Inappropriate disposal of parts, components, operating and auxiliary materials as well as cleaning media can cause environmental damage.</p> <ul style="list-style-type: none"> • Dispose of all components, parts, operating and auxiliary materials as well as cleaning agents professionally and in accordance with all locally applicable legal requirements and regulations. • In case of doubt regarding disposal, consult a local disposal company.

11.2 Disposal of operating and auxiliary materials

Operating material / auxiliary material	EU waste code
Adsorption materials, filter materials, cleaning wipes and protective clothing - contaminated by oils or other hazardous substances	15 02 02
Adsorption materials, filter materials, cleaning wipes and protective clothing - with the exception of those classified by 15 02 02	15 02 03
Packaging - paper and cardboard	15 01 01
Packaging - plastic material	15 01 02
Waste oil - mineral	13 02 05
Waste oil - synthetic	13 02 06

11.3 Disposal of components

Prerequisites	
1.	The product and the accessories have been shut down and dismantled.
2.	The product and the accessories have been cleaned and any fluid residue has been removed.

Components	EU waste code
Plastic material	20 01 39
Metals	20 01 40

12. Spare parts and accessories

12.1 Spare parts

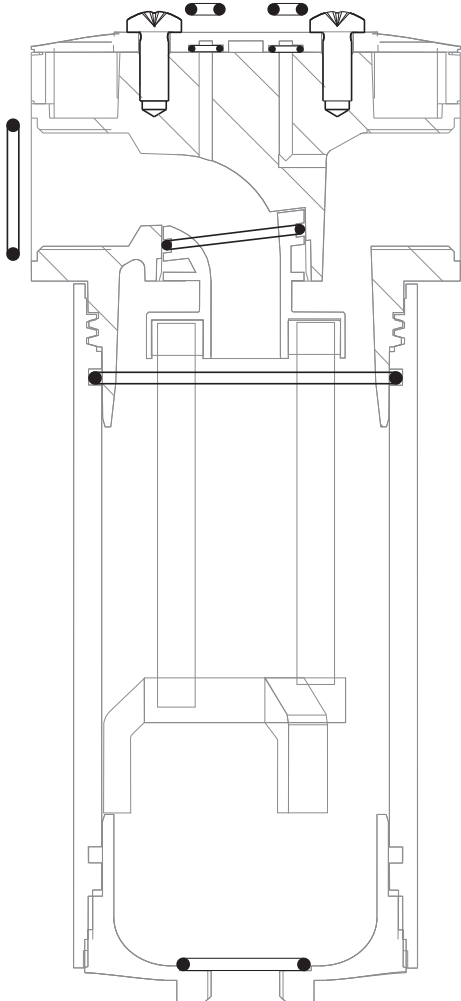
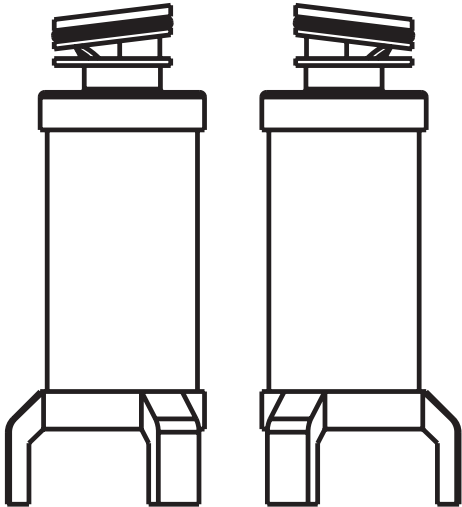
Illustration	Description / explanation	Material no.
	O-ring set for S040, S050, S055	4026562
	O-ring set for S075, M010, M012	4026563
	O-ring set for M015, M018, M020, M022, M023	4026564
	O-ring set for M025, M027, M030, M032	4026565
	Filter element	See type plate

12.2 Accessories

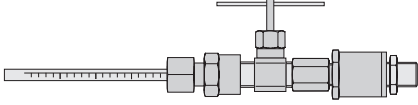
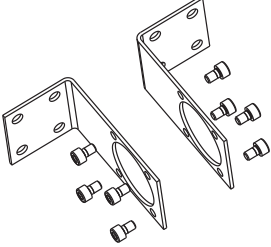
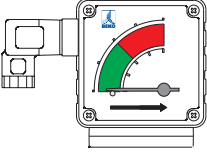
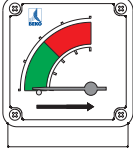
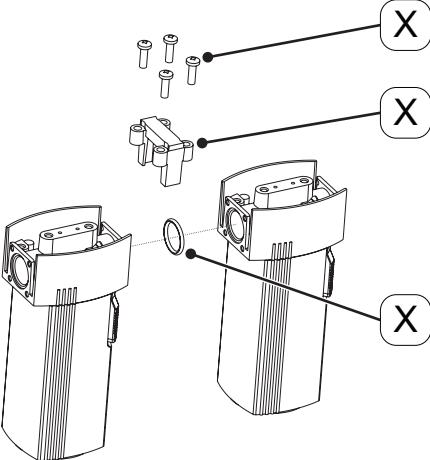
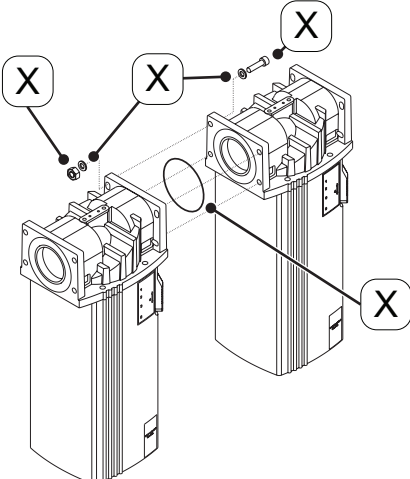
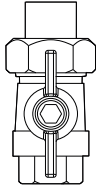
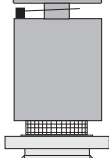

Illustration	Description / explanation	Material no.
	Oil test indicator for activated carbon filters	4005900
	Wall bracket for S040, S050, S055	4003328
	Wall bracket for S075, M010, M012	4003329
	Wall bracket for M015, M018, M020, M022, M023	4003330
	Wall bracket for M025, M027, M030, M032	4003331
	Differential pressure gauge with dry contact	4001481
	Differential pressure gauge without dry contact	4001491
	Connection kit [X] for S040, S050, S055	403332
	Connection kit [X] for S075, M010, M012	403333
	Connection kit [X] for M015, M018, M020, M022, M023	403334
	Connection kit [X] for M025, M027, M030, M032	403335

Illustration	Description / explanation	Material no.
	Manual condensate drain	2000039
	Float drain (open when not pressurised)	4025536
	Float drain (closed when not pressurised)	4025537
	BEKOMAT® 20	4001841
	BEKOMAT® 20 FM	4003051
	BEKOMAT® 31	4025098
	BEKOMAT® 32	4025088
	BEKOMAT® 33	4025091

13. Troubleshooting

Error or fault pattern	Possible causes	Troubleshooting
Inadequate filtration performance	Excessive load, load surges	<ul style="list-style-type: none"> Change the operating method Avoid pressure surges Observe the prescribed operating parameters, particularly during start-up processes
	Non-functioning condensate discharge	<ul style="list-style-type: none"> Check the condensate drain and replace it if necessary
	Incorrect dimensioning	<ul style="list-style-type: none"> Replace the current filter with a properly sized filter
	Filter element installed incorrectly	<ul style="list-style-type: none"> Observe the direction of flow of the pipe and the filter element
	O-ring has been damaged during installation	<ul style="list-style-type: none"> Replace the filter element and O-ring with new ones
High differential pressure	Incorrect dimensioning	<ul style="list-style-type: none"> Replace the current filter with a properly sized filter
	Excessive contamination	<ul style="list-style-type: none"> Shorten the maintenance interval for filter element replacements Check whether filtration in stages is required
	Damaged filter elements	<ul style="list-style-type: none"> Check whether a change in operating method or filtration in stages is required
Condensate in downstream components	Condensate drain defective or malfunctioning	<ul style="list-style-type: none"> Replace float drain or carry out maintenance on the BEKOMAT®
	Cooling downstream of filtration section	<ul style="list-style-type: none"> Drying upstream of filtration required
Leakage	Ageing seals	<ul style="list-style-type: none"> Replace seals
	Mechanical damage	<ul style="list-style-type: none"> Send in the filter for repair or replace with a new one

14. Appendices

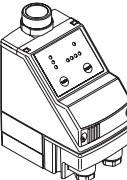
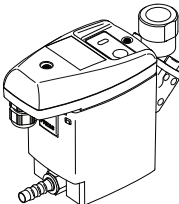
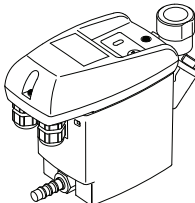
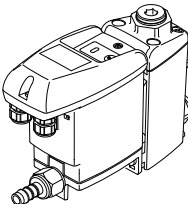
14.1 Manufacturer Declaration

BEKO TECHNOLOGIES GMBH
Im Taubental 7
41468 Neuss

GERMANY

Tel: +49 2131 988-0
ww.beko-technologies.com



Herstellererklärung

Wir erklären hiermit, dass die nachfolgend bezeichneten Produkte, in den von uns gelieferten Ausführungen gemäß Druckgeräterichtlinie 2014/68/EU Artikel 4 Absatz 3 in Übereinstimmung mit der geltenden guten Ingenieurpraxis ausgelegt und hergestellt werden.

Produktbezeichnung:	Behälter für Gewindefilter
Typbezeichnung:	CLEARPOINT®
Baugröße:	S040, S045, S050, S055, S075, S100, M010, M012, M015, M018
Max. Betriebsdruck:	16 bar (ü)

Beschreibung der Druckgeräte: Druckgeräte für Fluide der Gruppe 2

Druckgeräte nach Artikel 4 Absatz 3 der Druckgeräterichtlinie 2014/68/EU dürfen nicht die in Artikel 19 genannte CE-Kennzeichnung tragen.

Die Behälter wurden einer hydraulischen Druckprüfung mit 23 bar (ü), und einer Dichtheitsprüfung mit dem Medium Druckluft, bei 7,0 bar (ü) unterzogen. Bei den durchgeführten Prüfungen zeigten sich keine Mängel.

Neuss, 26.02.2020

BEKO TECHNOLOGIES GMBH

A handwritten signature in black ink, appearing to read "Christian Riedel".

i.V. Christian Riedel
Leiter Qualitätsmanagement International

BEKO TECHNOLOGIES GMBH
Im Taubental 7
41468 Neuss

GERMANY

Phone: +49 2131 988-0
www.beko-technologies.com



Manufacturer Declaration

We hereby declare that the products indicated hereafter, in the condition in which they have been placed into circulation, have been designed and manufactured according to sound engineering practice, in compliance with Article 4, Paragraph 3 of the European Pressure Equipment Directive 2014/68/EU.

Product designation:	Vessel for threaded filter
Model designation:	CLEARPOINT®
Construction size:	S040, S045, S050, S055, S075, S100, M010, M012, M015, M018
Max. operating pressure:	16 bar(g)
Description of the pressure equipment:	Pressure equipment for fluids of Group 2

Pressure equipment according to Article 4, Paragraph 3 of the European Pressure Equipment Directive 2014/68/EU must not bear the CE marking referred to in Article 19 of the above Directive.

The vessel was subjected to a hydraulic pressure test with 23 bar(g) and a leakage test with a compressed air media at 7.0 bar(g). The vessels passed both tests successfully and no defects were detected.

Neuss, 26.02.2020

BEKO TECHNOLOGIES GMBH

i.V. Christian Riedel
Head of International Quality Management

14.2 Declaration of Conformity

BEKO TECHNOLOGIES GMBH
Im Taubental 7
41468 Neuss

GERMANY

Tel: +49 2131 988-0
www.beko-technologies.com



EU-Konformitätserklärung

Wir erklären hiermit, dass das nachfolgend bezeichnete Produkt den Anforderungen der einschlägigen Richtlinien und technischen Normen entspricht. Diese Erklärung bezieht sich nur auf das Produkt in dem Zustand, in dem das Produkt von uns in Verkehr gebracht wurde. Nicht vom Hersteller angebrachte Teile und/oder nachträglich vorgenommene Eingriffe bleiben unberücksichtigt.

Produktbezeichnung:	Behälter für Gewindefilter CLEARPOINT® ...
Modelle:	M019, M020, M022, M023
Max. Betriebsdruck:	16 bar(ü)
Produktbeschreibung und Funktion:	Behälter für CLEARPOINT® Gewindefilter

Druckgeräte-Richtlinie 2014/68/EU

Angewandtes Konformitätsbewertungsverfahren:	Modul A
Kategorie:	I
Beschreibung der Druckgeräte:	Behälter für Fluide der Gruppe 2

Der Hersteller trägt die alleinige Verantwortung für die Ausstellung dieser Konformitätserklärung.

Neuss, 21.03.2022

Unterzeichnet für und im Namen von:

BEKO TECHNOLOGIES GMBH

(Handwritten Signature)
i.V. Christian Riedel

Leiter Qualitätsmanagement International

BEKO TECHNOLOGIES GMBH
 Im Taubental 7
 41468 Neuss

GERMANY

Phone: +49 2131 988-0
 www.beko-technologies.com



EU Declaration of Conformity

We hereby declare that the product specified below complies with the requirements of the applicable directives and technical standards. This declaration only refers to the product in the condition in which it has been placed on the market by us. Parts which have not been installed by the manufacturer and/or modifications which have been implemented subsequently remain unconsidered.

Product designation:	Container for threaded filter CLEARPOINT® ...
Models:	M019, M020, M022, M023
Max. operating pressure:	16 bar(g)
Product description and function:	Container for CLEARPOINT® threaded filter

Pressure Equipment Directive 2014/68/EU

Conformity assessment process applied:	Module A
Category:	I
Description of pressure equipment:	Container device for fluids of Group 2

The manufacturer bears sole responsibility for issuing this Declaration of Conformity.

	Signed for and on behalf of:
Neuss, 03/21/2022	BEKO TECHNOLOGIES GMBH

i.V. Christian Riedel
 Head of International Quality Management

BEKO TECHNOLOGIES GMBH
Im Taubental 7
41468 Neuss

GERMANY

Tel: +49 2131 988-0
www.beko-technologies.com



EU-Konformitätserklärung

Wir erklären hiermit, dass die nachfolgend bezeichneten Produkte den Anforderungen der einschlägigen Richtlinien und technischen Normen entsprechen. Diese Erklärung bezieht sich nur auf die Produkte in dem Zustand, in dem sie von uns in Verkehr gebracht wurden. Nicht vom Hersteller angebrachte Teile und/oder nachträglich vorgenommene Eingriffe bleiben unberücksichtigt.

Produktbezeichnung:	Behälter für Gewindefilter CLEARPOINT® ...
Modelle:	M025, M027, M030, M032
Max. Betriebsdruck:	16 bar (ü)
Produktbeschreibung und Funktion:	Behälter für CLEARPOINT® Gewindefilter

Druckgeräte-Richtlinie 2014/68/EU

Angewandtes Konformitätsbewertungsverfahren:	Modul A2
Kategorie:	II
Beschreibung der Druckgeräte:	Druckgeräte für Fluide der Gruppe 2
Notifizierte Stelle:	TÜV NORD Systems GmbH & Co. KG Große Bahnstraße 31 22525 Hamburg
Zertifikatsnummer:	07/202/1410/Z/0237/17/D/0035

Die Produkte sind mit dem abgebildeten Zeichen gekennzeichnet:

CE 0045

Der Hersteller trägt die alleinige Verantwortung für die Ausstellung dieser Konformitätserklärung.

Unterzeichnet für und im Namen von:

Neuss, 26.02.2020

BEKO TECHNOLOGIES GMBH

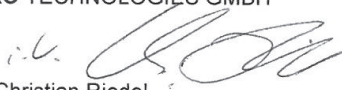
i.V. Christian Riedel
Leiter Qualitätsmanagement International

BEKO TECHNOLOGIES GMBH
Im Taubental 7
41468 Neuss

GERMANY

Phone: +49 2131 988-0
www.beko-technologies.com



EU Declaration of Conformity

We hereby declare that the products named below comply with the stipulations of the relevant directives and technical standards. This declaration only refers to products in the condition in which they have been placed into circulation. Parts which have not been installed by the manufacturer and/or modifications which have been implemented subsequently remain unconsidered.

Product designation:	Vessel for threaded filters CLEARPOINT®
Types:	M025, M027, M030, M032
Max. operating pressure:	16 bar(g)
Product description and function:	Vessel for CLEARPOINT® threaded filters

Pressure Equipment Directive 2014/68/EU

Applied conformity assessment procedure:	Module A2
Category:	II
Description of the pressure equipment:	Pressure equipment for fluids of Group 2
Notified body	TÜV NORD Systems GmbH & Co. KG Große Bahnstraße 31 22525 Hamburg Germany
Certificate number:	07/202/1410/Z/0237/17/D/0035

The products bear the CE Mark:

CE0045

The manufacturer shall have sole responsibility for issuing this declaration of conformity.

Neuss, 26.02.2020

Signed for and on behalf of:

BEKO TECHNOLOGIES GMBH

i.V. Christian Riedel
Head of International Quality Management

BEKO TECHNOLOGIES GmbH

Im Taubental 7
 D - 41468 Neuss
 Tel. +49 2131 988 0
 Fax +49 2131 988 900
 info@beko-technologies.com
 service-eu@beko-technologies.com

DE**BEKO TECHNOLOGIES LTD.**

Unit 11-12 Moons Park
 Burnt Meadow Road
 North Moons Moat
 Redditch, Worcs, B98 9PA
 Tel. +44 1527 575 778
 info@beko-technologies.co.uk

GB**BEKO TECHNOLOGIES S.à.r.l.**

Zone Industrielle
 1 Rue des Frères Rémy
 F - 57200 Sarreguemines
 Tél. +33 387 283 800
 info@beko-technologies.fr
 service@beko-technologies.fr

FR**BEKO TECHNOLOGIES B.V.**

Veenen 12
 NL - 4703 RB Roosendaal
 Tel. +31 165 320 300
 benelux@beko-technologies.com
 service-bnl@beko-technologies.com

NL**BEKO TECHNOLOGIES
(Shanghai) Co. Ltd.**

Rm.715 Building C, VANTONE Center
 No.333 Suhong Rd.Minhang District
 201106 Shanghai
 Tel. +86 (21) 50815885
 info.cn@beko-technologies.cn
 service1@beko.cn

CN**BEKO TECHNOLOGIES s.r.o.**

Na Pankraci 58
 CZ - 140 00 Praha 4
 Tel. +420 24 14 14 717 /
 +420 24 14 09 333
 info@beko-technologies.cz

CZ**BEKO Tecnológica España S.L.**

Torruella i Urpina 37-42, nave 6
 E - 08758 Cervelló
 Tel. +34 93 632 76 68
 Mobil +34 610 780 639
 info.es@beko-technologies.es

ES**BEKO TECHNOLOGIES LIMITED**

Room 2608B, Skyline Tower,
 No. 39 Wang Kwong Road
 Kwloon Bay Kwloon, Hong Kong
 Tel. +852 2321 0192
 Raymond.Low@beko-technologies.com

HK**BEKO TECHNOLOGIES INDIA Pvt. Ltd.**

Plot No.43/1 CIEEP Gandhi Nagar
 Balanagar Hyderabad
 IN - 500 037
 Tel. +91 40 23080275 /
 +91 40 23081107
 Madhusudan.Masur@bekoindia.com
 service@bekoindia.com

IN**BEKO TECHNOLOGIES S.r.l**

Via Peano 86/88
 I - 10040 Leinì (TO)
 Tel. +39 011 4500 576
 Fax +39 0114 500 578
 info.it@beko-technologies.com
 service.it@beko-technologies.com

IT**BEKO TECHNOLOGIES K.K**

KEIHIN THINK Building 8 Floor
 1-1 Minamiwatarida-machi
 Kawasaki-ku, Kawasaki-shi
 JP - 210-0855
 Tel. +81 44 328 76 01
 info@beko-technologies.jp

JP**BEKO TECHNOLOGIES Sp. z o.o.**

ul. Pańska 73
 PL - 00-834 Warszawa
 Tel. +48 22 314 75 40
 info.pl@beko-technologies.pl

PL**BEKO TECHNOLOGIES S. de R.L. de C.**

BEKO Technologies, S de R.L. de C.V.
 Blvd. Vito Alessio Robles 4602 Bodega 10
 Zona Industrial
 Saltillo, Coahuila, 25107
 Mexico
 Tel. +52(844) 218-1979
 informacion@beko-technologies.com

MX**BEKO TECHNOLOGIES, CORP.**

900 Great Southwest Pkwy SW
 Atlanta, GA 30336
 USA
 Tel. +1 404 924-6900
 beko@bekousa.com

US