

Original installation and operating manual

CLEARPOINT® V

Activated Carbon Filter with Cartridge

- > S055
- > M010X
- > M018

■ Table of contents

- 1. Information on documentation4**
 - 1.1 Contact4
 - 1.2 Information regarding installation and operating manual.....4
 - 1.3 Additional valid documents..... 5
- 2. Safety.....6**
 - 2.1 Use.....6
 - 2.1.1 Intended use6
 - 2.1.2 Foreseeable misuse7
 - 2.2 Responsibility of the operator7
 - 2.3 Target group and personnel8
 - 2.4 Explanation of the symbols used.....9
 - 2.5 Safety instructions and warning notices10
 - 2.5.1 Basic safety instructions.....10
 - 2.5.2 Safe operation.....10
 - 2.5.3 Sudden escape of pressurized fluids11
 - 2.5.4 Transportation and storage11
 - 2.5.5 Installation12
 - 2.5.6 Maintenance12
 - 2.5.7 Handling hazardous substances13
 - 2.5.8 Use of spare parts, accessories, and materials.....13
 - 2.6 Warning notices14
- 3. Product information 15**
 - 3.1 Product description15
 - 3.2 Product overview16
 - 3.3 Product identification17
 - 3.4 How it works19
 - 3.5 Product designation20
 - 3.5.1 Maintenance sticker for cartridge replacements20
 - 3.5.2 Type plate.....21
 - 3.5.3 Scope of delivery22
- 4. Technical data 23**
 - 4.1 Operating parameters23
 - 4.2 Materials24
 - 4.3 Dimensions.....25
 - 4.4 Installation conditions26
- 5. Transportation and storage 27**
 - 5.1 Warning notices27
 - 5.2 Transportation27
 - 5.3 Storage.....27

6. Installation	28
6.1 Warning notices	28
6.2 Preparation work	29
6.3 Positioning the filter	30
6.4 Installation work	31
6.5 Installing accessories	31
6.6 Concluding work	31
7. Commissioning	32
7.1 Warning notices	32
7.2 Commissioning work	32
8. Maintenance	33
8.1 Warning notices	33
8.2 Maintenance plan	33
8.3 Maintenance work	34
8.3.1 Cleaning	34
8.3.1.1 Warning notices	34
8.3.1.2 Cleaning work	34
8.4 Replacing the cartridge	35
8.4.1 Visual inspection	39
9. Removal from service	40
9.1 Warning notices	40
9.2 Removal from service	40
10. Disassembly	41
10.1 Warning notices	41
10.2 Disassembly work	41
11. Disposal	43
11.1 Warning notices	43
11.2 Disposal of components	43
12. Spare parts and accessories	44
12.1 Spare parts	44
12.2 Accessories	45
13. Troubleshooting	47
14. Appendices	48
14.1 Manufacturer declaration	48
15. Notes	50

1. Information on documentation

This documentation contains all the necessary steps for use of the product and the accessories.

1.1 Contact

Manufacturer	Service and tools
<p>BEKO TECHNOLOGIES GmbH</p> <p>Im Taubental 7 41468 Neuss Phone: +49 2131 988-1000 info@beko-technologies.com www.beko-technologies.com</p>	<p>BEKO TECHNOLOGIES GmbH</p> <p>Im Taubental 7 41468 Neuss Phone: +49 2131 988-1000 service-eu@beko-technologies.com www.beko-technologies.com</p>

INFORMATION	Country specific manufacturer representation
	<p>You can contact the country-specific manufacturer's representative via the address listed in the address section on the rear cover or by using the contact form on the manufacturer's website.</p>

1.2 Information about this installation and operating manual

INFORMATION	Copyright protection
	<p>The contents of the installation and operating manual in the form of text, figures, illustrations, photographs, technical drawings, diagrams and other representations are protected by the copyright of the manufacturer. The distribution as well as the duplication of this document, the exploitation and the communication of its contents are prohibited unless expressly authorized.</p>

Publication date	Revision	Version	Reason for change	Scope of change
October 22, 2020	01	00	Technical and editorial changes	Amendment
May 20, 2025	02	00	Technical and editorial changes	Amendment

The installation and operating manual, hereinafter referred to as the manual, must always be kept close to the product and be in a permanently legible condition.

The manual must be handed over along with the product if it is sold or passed on.

NOTICE	Follow the instructions given in the manual
	This manual contains all the basic information required for safe operation of the product and must be read before any actions are performed. Otherwise personal and material hazards as well as malfunction and device failure are possible.

1.3 Other applicable documents

This manual describes all steps required to install and operate **CLEARPOINT® V** activated carbon filters with a cartridge.

More detailed information about the installation and operation of the accessories is contained in the following installation and operating manuals:

- **CLEARPOINT®** Oil test indicator

2. Safety

2.1 Use

2.1.1 Intended use

The **CLEARPOINT® V** activated carbon filter with a cartridge, hereafter also referred to as the “filter” or “product,” is used to adsorb oil vapors and odors in pressurized gas systems.

Any use of this system other than the use described in this manual is hereby deemed to be non-intended and can cause a hazard for the safety of people and the environment.

The following must be noted for intended use:

- Read and follow the manual.
- Use the product and the accessories exclusively within the operating parameters specified in the “Technical data” section and in accordance with the agreed terms of supply.
- Only operate the product and accessories with media which are free of caustic, aggressive, corrosive, toxic, flammable, oxidizing and inorganic components. In cases of doubt an analysis must be carried out.
- Only use the product and accessories in areas which are free of toxic and corrosive chemicals and gases.
- Use the product and accessories exclusively within a pipeline system designed for the operating parameters specified in the ““Technical data”” section. The system must feature appropriate connections, pipe diameters, and assembly clearances.
- Only use the product and accessories outside potentially explosive atmospheres.
- Only use the product and accessories outside of areas exposed to direct sunlight and heat sources, as well as outside of areas at risk of frost.
- Combine the product and the accessories only with the recommended manufacturer products and components indicated in this manual.
- Adhere to the specified maintenance plan.

Before using the product and the accessories, the operating company must make sure that all conditions and prerequisites for intended use are given.

The product and the accessories have been exclusively designed for stationary use in a commercial or industrial area. All of the assembly, installation, operation, maintenance, disassembly and disposal work described may only be performed by qualified skilled technical personnel.

2.1.2 Foreseeable misuse

Foreseeable misuse is deemed to have occurred if the product or the accessories are used in any other way than that described in the section “Intended use”. Foreseeable misuse includes using the product or accessories in a manner that is not intended by the manufacturer or suppliers but that may occur due to foreseeable human behavior.

Foreseeable misuse includes:

- The execution of any kind of modification, in particular constructive and process-technology related interventions.
- The suspension, bridging or non-application of existing or recommended safety equipment.

This list is not exhaustive as not all possible inappropriate use can be foreseen in advance. If the operating company is aware of any inappropriate use of the product or accessories which are not listed here, the manufacturer must be informed immediately.

2.2 Responsibility of the operating company

The responsible operating company must ensure the following to prevent accidents, incidents and adverse effects on the environment:

- Before all actions, check to ensure that the manual available does in fact belong to the product.
- The product and the accessories are used, serviced and repaired in accordance with the intended use.
- The product and accessories are only used with the recommended and fully operable safety equipment.
- All assembly, installation and maintenance work is carried out by qualified skilled technical personnel only.
- Personnel have the required personal protective equipment, and this equipment is used.
- Suitable technical safety measures are taken to ensure that the permissible operating parameters are observed.
- Keep all safety symbols and the type plate on the product and accessories in a legible state. Replace damaged and illegible markings immediately.

2.3 Target group and personnel

This manual is intended for the personnel listed below that is involved with work on the product or its accessories.

INFORMATION	Personnel requirements
	<ul style="list-style-type: none"> • Minors are strictly prohibited from working with and on the product and its accessories. • The personnel may not execute any actions on the product or the accessories when they are under the influence of drugs, medications, alcohol or other substances that may impair their consciousness.

Operating personnel

Operating personnel are persons who are able to operate the product and the accessories safely on the basis of knowledge of the manual and instruction in the use of the product and accessories. Operating personnel can recognize possible malfunctions and dangerous situations independently and arrange for corresponding measures.

Skilled technical personnel specialized in transportation and storage

Skilled technical personnel specialized in transportation and storage are people who, due to their training, professional experience and qualifications, have all the necessary skills to safely execute all actions in connection with the transportation and storage of the product, to instruct, to recognize possible dangerous situations independently and to execute measures to avoid danger.

The skills required include, in particular, experience operating hoists, forklifts and lifting equipment and familiarity with locally applicable laws, standards and guidelines relating to transportation and storage.

Skilled technical personnel specialized in pressure equipment and systems

Skilled technical personnel specialized in pressure equipment and systems are people who, as a result of their training, professional experience and qualifications, have all the necessary capabilities to safely carry out and order all activities related to pressurized fluids and systems, to independently identify potentially hazardous situations, and to implement appropriate measures to avert any danger.









The skills required include, in particular, experience using measuring equipment and control equipment, as well as familiarity with locally applicable laws, standards and regulations for pressurized systems.

Qualified service technicians

Qualified service technicians are persons who have the skills and qualifications as defined in all the aforementioned definitions concerning skilled technical personnel. Qualified service technicians must be verifiably trained and authorized for all work on the product.

2.4 Explanation of the symbols used

The symbols used below indicate safety-relevant and important information which must be adhered to when handling the product and to ensure safe and optimum operation.

Symbol	Description / explanation
	General hazard symbol (danger, warning, caution)
	Pressurized system
	Read and follow the installation and operating manual
	General instruction symbol
	Wear safety footwear
	Use protective gloves (cut-proof and liquid-resistant)
	Wear hearing protection
	Wear safety goggles with side shields
	General information

2.5 Safety instructions and warning notices

This section provides an overview of all the important safety aspects for personal protection as well as for the safe and problem-free operation of the product and accessories.

The following sections list the dangers posed by this product and the accessories even with intended use. To minimize the risk of personal injury and property damage and to avoid dangerous situations, observe the safety instructions listed and adhere to the warning notices in the other sections of this manual.

Basic warning notices and the necessary qualifications of skilled technical personnel are always listed at the beginning of the section in the “Warning notices” section.

Warning notices related to specific actions are printed directly before potentially hazardous procedures or sequences of actions.

As well as causing personal injury, failure to observe safety instructions and warning notices may result in malfunctions, disruption to operations, and property damage.

2.5.1 Basic safety instructions

- Before starting work, refer to the technical documentation for the entire system and observe the overall operating instructions.
- Carry out a risk assessment before starting work on site (last minute risk assessment).
- Use suitable personal protective equipment for all work.
- Set up a safety area around the working area during all installation, maintenance and repair work.
- Use existing system-specific protection procedures (e.g., LOTO procedure) to safely de-energize and isolate the system or system sections.

2.5.2 Safe operation

The following actions may result in serious injury or death:

- Setting up and operating the product and accessories outside the permissible limits and operating parameters
- Unauthorized interference and unauthorized modifications of the product and accessories

To guarantee the safe operation of the product and accessories, observe the following:

- Observe the limits and operating parameters specified on the type plate and in the manual.
- Check whether the permissible operating parameters have been changed or restricted by the use of accessories.
- Observe the installation conditions and the ambient conditions.
- Adhere to the maintenance intervals.

2.5.3 Sudden escape of pressurized fluids

The following situations may result in serious injury or death:

- Contact with fast or suddenly escaping fluids
- Bursting system components
- Whipping of pressurized hoses and pipes

For the safe handling of pressurized systems, observe the following:

- Observe the following safety rules during all work:
 1. Shut down the system or system section.
 2. Secure the system or system section against restarting.
 3. Reduce the pressure in the system or all system sections to the ambient pressure.
e.g. by slowly releasing the pressure in a controlled manner via relief valves
 4. Lock out and tag out the system or system section so that it cannot be pressurized again.
- Check the pressurized system or system section for safety, contamination and possible damage.
- Before pressurization, check all system connections for leak tightness and tighten if necessary.
- Make absolutely sure to charge the system or system section with pressure slowly.
- Avoid pressure blows and high differential pressures.
- Compensate any vibrations occurring in the pipe network by using vibration dampers.

2.5.4 Transportation and storage

Improper transportation and improper storage may result in personal injury or property damage.

In order to ensure safety during the transportation and storage of the product and accessories, observe the following:

- Use personal protective equipment for all work with packaging material.
- Handle packaging, the product and accessories carefully.
- Transport and handle the product and accessories according to the markings on the packaging.
- Use only proper transportation, lifting and lashing equipment that is in proper working order.
- Use only transportation, lifting and lashing equipment that are rated for the total weight of the product.
- Always adhere to the permissible transportation and storage parameters.
- Store the product and accessories only outside of areas exposed to direct sunlight and heat sources.

2.5.5 Installation

Improper physical or electrical installation of the product and accessories may result in personal injury and property damage as well as impair operation.

For safe physical and electrical installation, observe the following:

- Install the product, the accessories, and all parts and materials used so that they are not subject to mechanical tension.
- Check all plug-type connections for a correct fit.
- Prevent trip hazards by routing hoses appropriately.
- Fix and fasten hoses in such a way that they cannot flap around.
- Install the inlet and drain lines as fixed pipes.

2.5.6 Maintenance

Improper performance of maintenance and repair work can result in serious injury or death.

For safe maintenance and repairs, observe the following:

- Before starting work, depressurize the pressurized product and accessories and secure them against unintentional pressurization.
- Only use materials approved for the respective application.
- Use only suitable tools that are in proper working order.
- Only use cleaned pipes and hoses that are free of dirt and corrosion.
- Never use abrasive or aggressive cleaning agents or solvents which could damage the outer coating (e.g. markings, type plate, corrosion protection, etc.).
- Never clean the device with hard or pointed tools.
- Use only the specified materials and media for cleaning.
- Observe statutory, local and in-house hygiene regulations.
- Pay attention to order and cleanliness during maintenance and repair work. Prevent contamination from entering the opened product or accessories. Store disassembled components and accessories directly in a safe place.
- After completing maintenance and repair work, remove all tools and cleaning agents used, as well as all parts that are no longer needed, from the work area.
- Only dispose of the product and accessories when cleaned and freed of any residue.
- Dispose of all components, parts, operating and auxiliary materials as well as cleaning agents professionally and in accordance with all locally applicable legal requirements and regulations.

2.5.7 Handling hazardous substances

Contact with condensate containing substances which endanger health and the environment can pose a health hazard, causing irritation and/or damage to the eyes, skin and mucous membranes. In addition, polluted condensate must be prevented from entering the sewage system, waters or the ground.

For the safe handling of polluted condensate, observe the following:

- Use suitable protective equipment when handling condensate.
- Collect and dispose of any leaking or spilled condensate in accordance with locally applicable legal requirements and regulations.

2.5.8 Use of spare parts, accessories or materials

The use of incorrect spare parts, accessories or materials, as well as auxiliary and operating materials, may result in death or serious injury. Malfunction and device failure as well as material damage can occur.

- Only use undamaged original parts, auxiliary and operating materials which are specified by the manufacturer to complete all work.
- Only use the materials approved for the respective application and suitable tools in proper working order.
- Only use cleaned pipes that are free of dirt and corrosion.
- Only use electric components and materials that comply with locally applicable legal requirements and regulations (standards, directives, etc.) for electrical safety.

2.6 Warning notices

Warning notices warn against dangers when handling the product and accessories.

Failure to observe warning notices may result in personal injury, damage to property, and impairment to operations.

Structural set up:

SIGNAL WORD	Type and source of danger
 Symbol	Possible consequences if the danger is ignored <ul style="list-style-type: none"> • Measures to prevent the danger

Signal words:

DANGER	Imminent hazard Consequences of non-compliance: Death or serious personal injury
WARNING	Imminent hazard Consequences of non-compliance: Death or serious personal injury are possible
CAUTION	Potential hazard Consequences of non-compliance: Personal injury is possible
NOTICE	Possible damage to property Consequences of non-compliance: Damage to property, malfunction and device failure are possible. No hazard to people or endangerment of safe operation.

3. Product information

3.1 Product description

CLEARPOINT® V activated carbon filters with a cartridge are used to separate oil vapors and odorants from gas mixtures in pressurized systems. The residual oil content in the corresponding gas mixture can be measured over an extended period of time ($t > \text{hundred hours}$) with an oil test indicator.

The compressed air's moisture content and temperature must not exceed 30% and +45 °C respectively. If these limits are exceeded, the cartridge will have a shorter service life!

The activated carbon filter's service life will depend on the following factors:

- Oil content
- Relative humidity
- Pressure
- Temperature:

3.2 Product overview

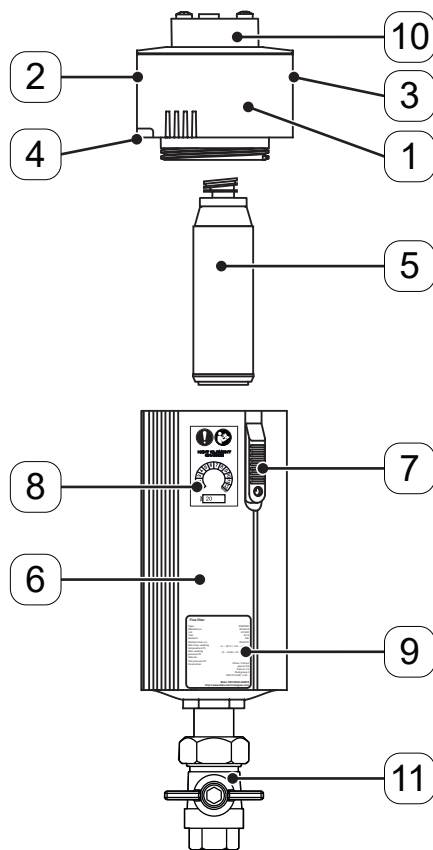

Position no.	Description / explanation
[1]	Housing head
[2]	Inlet on housing head
[3]	Outlet on housing head
[4]	Direction indicator
[5]	Activated carbon cartridge
[6]	Housing
[7]	Safety slide with locking screw
[8]	Maintenance sticker for cartridge replacements
[9]	Type plate
[10]	Adapter
[11]	Manual drain

Top attachments		
Position no.	Abbreviation	Description / explanation
[3]	W	No display device
	I	Oil test indicator

Cartridge		
Position no.	Size: Housing	Cartridge
[2]	S055	06V
	M010X	10V
	M018	18V

Housing			
Position no.	Model series	Size	Volume l (gal)
[1]	S	055	0.42 (0.11)
	M	010X	1.12 (0.3)
	M	018	2.97 (0.78)

Bottom attachments		
Position no.	Abbreviation	Description / explanation
[4]	M	Manual drain

3.4 Function description

In **CLEARPOINT® V** systems, fluid flows from top to bottom through the cartridge. This fluid enters from above through a small filter element that separates coarse particles. From there, the fluid enters the inside of the cartridge and then passes through the cartridge and into the container. During this process, the activated carbon in the adsorption material adsorbs oil vapors and odors.

Among other things, the cartridge's service life depends on the oil content in the fluid, since the adsorption material can only adsorb a limited amount of oil vapors and odors.

Please note that the hydrocarbons in the fluid will not be adsorbed 100% by the activated carbon: The adsorption capacity for hydrocarbons depends not only on the properties of the activated carbon (raw materials, grain size, pore size, etc.), but also, and above all, on the structure and polarity of the gas fractions being adsorbed.

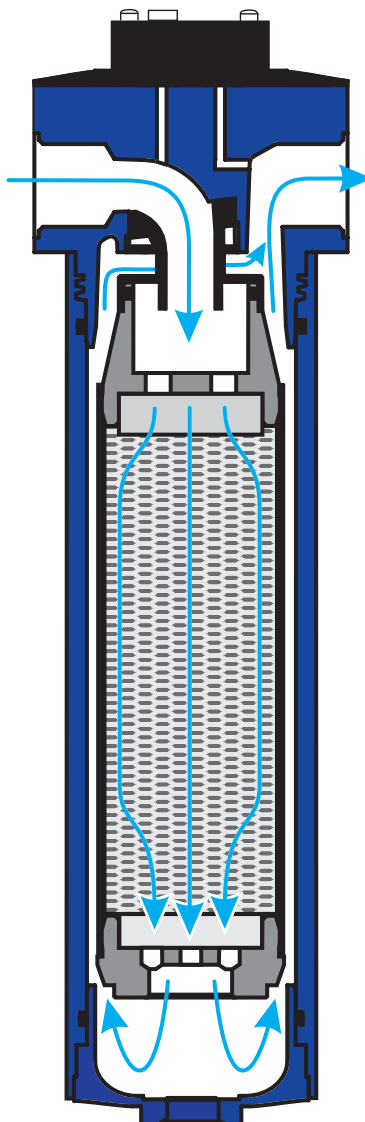

3.5 Product designation

3.5.1 Maintenance sticker for cartridge replacements

The maintenance sticker is used to write down the next cartridge replacement date. To do this, mark the corresponding month **[1]** and write down the year **[2]** with a permanent marker.

Every cartridge comes with a maintenance sticker included.

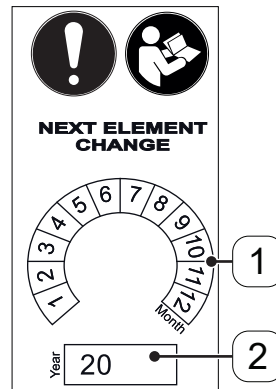

Position no.	Description / explanation
[1]	Month of next cartridge replacement date
[2]	Year of next cartridge replacement date

3.5.2 Type plate

The type plate is located on the housing, and provides identification and operating parameters for the filter. Please have this information ready when contacting the manufacturer or supplier so that it is possible to quickly identify your product.

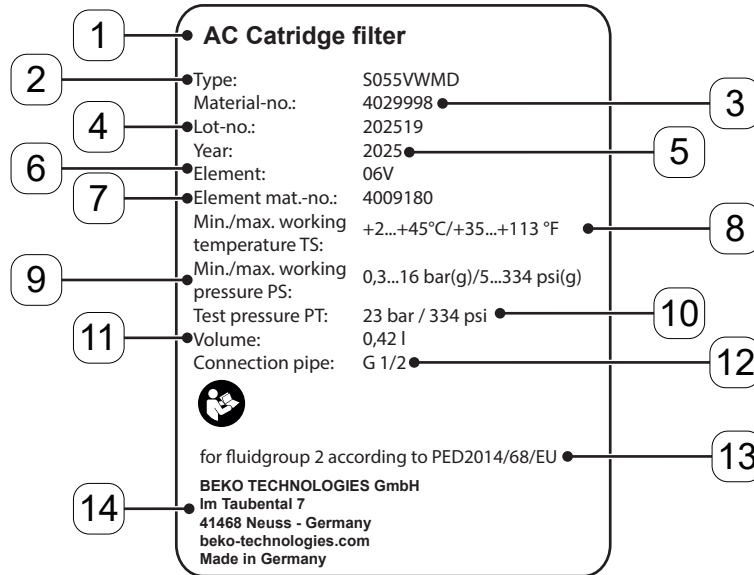

Type plate example

Position no.	Description / explanation
[1]	Product name
[2]	Product designation
[3]	Material number
[4]	Batch number
[5]	Production year
[6]	Cartridge designation
[7]	Cartridge part number
[8]	Min. / max. operating temperature
[9]	Min. / max. operating pressure
[10]	Test pressure
[11]	Housing volume
[12]	Inlet and outlet threaded connections
[13]	Fluid group and category according to Pressure Equipment Directive 2014/68/EU
[14]	Manufacturer's address

3.5.3 Scope of delivery

The following table shows the scope of delivery for the filter:

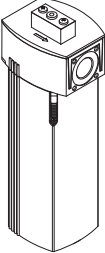
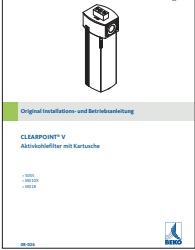
Figure	Description / explanation
	<p>Activated Carbon Filter with Cartridge</p>
	<p>Original installation and operating manual</p>

4. Technical data

4.1 Operating parameters

CLEARPOINT® V	S055	M010X	M018
Threaded connection	1/2"	3/4"	1 1/2"
Volumetric flow rate, energy-optimized ^{*1}	50 m ³ /h 29.5 ft ³ /min	100 m ³ /h 59 ft ³ /min	200 m ³ /h 118 ft ³ /min
Category according to PED 2014/68/EU	-	-	-
Min. / max. operating pressure PS	0.3 ... 16 bar(g) 4.4 ... 232 psi(g)		
Min. / max. operating temperature TS	+2 ... +45 °C 35 ... 113 °F		
Maximum relative humidity of fluid	30% at +20 °C (+68 °F)		
Recommended operating temperature	25 °C 77 °F		
Fluid class at inlet (in conformity with ISO 8573-1)	[2:2:1]		
Fluid	Compressed gases in fluid group 2 in accordance with PED 2014/68/EU, free from aggressive and corrosive components		
Load test in accordance with DIN EN 13445-3	Full load cycles with $\Delta p = PS$: 10000 Partial load cycles with $\Delta p < PS$: 10000 x $(PS/\Delta p)^3$		
Cartridge service life ^{*1, *2}	2000 h	3500 h	3500 h
Weight	1.5 kg 3.3 lbs	2.5 kg 5.5 lbs	6 kg 13.23 lbs
Volume	0.42 l 0.11 gal	1.12 l 0.3 gal	2.97 l 0.78 gal

^{*1} Volumetric flow rate with 7 bar(g) (102 psi(g)) based on +20 °C (+68 °F) and 1 bar(a) (14.5 psi(a)); reference values in conformity with DIN 7183

^{*2} Service life with a fluid temperature of +25 °C (+77 °F), 30% relative humidity, and a maximum oil inlet concentration of approx. 0.08 mg/m³

4.2 Materials

Filter	
Component	Material
Housing head, housing	Aluminum, coated
Housing lid	Polyamide
Housing base	Aluminum, coated
M5 screws	Steel, galvanized
Safety slide	Zinc
O-rings	Standard: NBR Oil-free: FKM
Manual drain	Brass, nickel-plated
Wall bracket	Steel, galvanized
Sticker	PVC and polyacrylate

Cartridge	
Component	Material
Cartridge head	Aluminum
Cylindrical mesh screen	Stainless steel
Cartridge body	Aluminum, anodized
Cartridge bottom	Aluminum, anodized
O-rings	Elastomer
Filter foam	Polyurethane foam
BGR filter element head	Polyamide and fiberglass
Activated carbon fill	Activated carbon

4.3 Dimensions

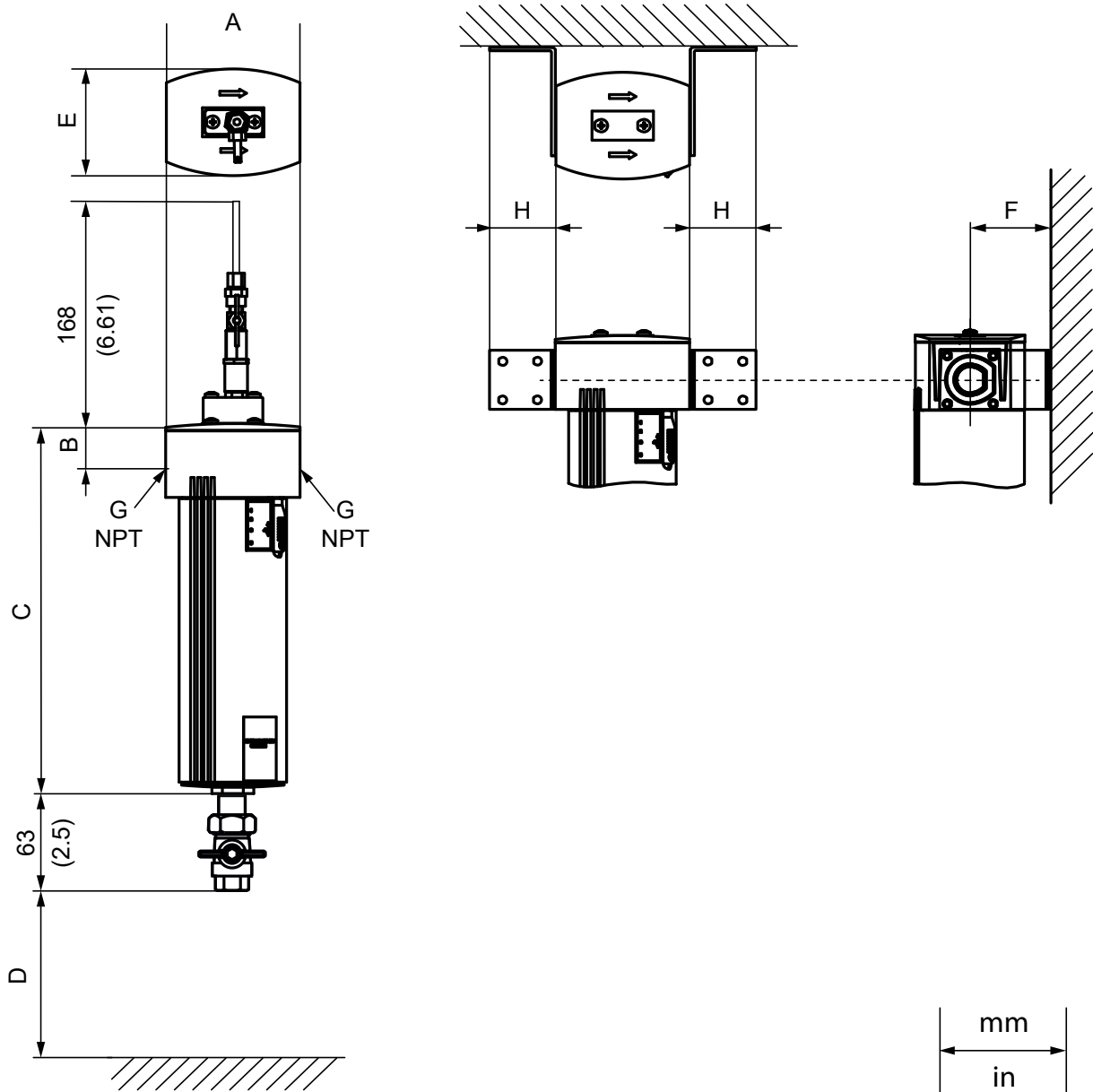

Filter (Size)	A	B	C	D	E	F	H	Cartridge
	mm (in)							
S055	75 (2.95)	28 (1.10)	267 (10.51)	150 (5.91)	61 (2.40)	64.5 (2.54)	39.5 (1.56)	06V
M010X	100 (3.94)	33 (1.29)	352 (13.86)	150 (5.91)	81 (3.18)	63 (2.48)	45 (1.77)	10V
M018	146 (5.75)	47 (1.85)	416 (16.39)	200 (7.87)	119 (4.68)	78.5 (3.09)	60 (2.36)	18V

4.4 Installation conditions

- Install an upstream fluid treatment system (filtration and drying).
- The set-up location must be inside of a building used for industrial purposes.
- Set up the product at an adequate distance from potential sources of vibration and pulsation (e.g., machines).
- The setup location must ensure that there is sufficient clearance for working with and on the product (e.g., installation, maintenance, retrofitting accessories).
- Install the product in a clean and dry area that is not exposed to direct sunlight, frost, heat sources, and/or potential sources of fire.
- Set up the product outside of traffic routes, and attach collision protection to the product.
- In order to be able to carry out maintenance work, install a manual shutoff valve both at the product's inlet and outlet.
- In order to ensure that the general system can continue to be supplied with fluid even during maintenance and servicing work, the manufacturer recommends installing a bypass line **[3]** with a fluid treatment unit and shutoff valves **[1, 2]**, as well as a condensate drain line that can be disconnected from the manual drain.
- The pipes must be able to support the additional weight of the product.
Install any additional necessary fasteners or mounts.

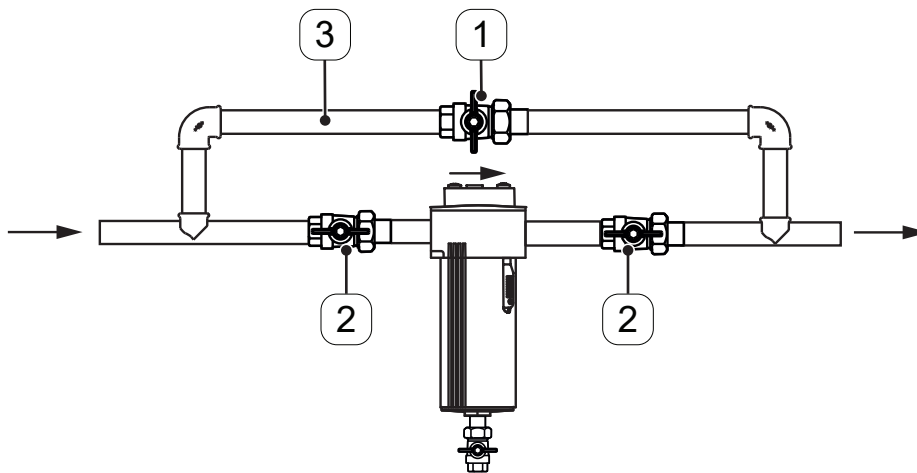



5. Transportation and storage

Personnel

Skilled technical personnel specialized in transportation and storage
(see section “2.3 Target group and personnel” on page 8)

5.1 Warning notices

CAUTION	Improper transportation or storage
	Improper transportation or storage may result in personal injury.
	<ul style="list-style-type: none"> • Use personal protective equipment for all work with packaging material. • Use only proper transportation, lifting and lashing equipment that is in proper working order. • Use only transportation, lifting and lashing equipment that are rated for the total weight of the product. • Always adhere to the permissible transportation and storage parameters.
NOTICE	Handling packaging materials
	The improper disposal of packaging materials may result in environmental damage.
	<ul style="list-style-type: none"> • Dispose of the packaging material in accordance with the applicable legal requirements and regulations of the country and place of use.

5.2 Transportation

- Transport and handle the product and accessories according to the markings on the packaging.
- Pack all parts impact-proof using suitable material.
- Handle packaging, the product and accessories carefully.



5.3 Storage

- Store the product and accessories only outside of areas exposed to direct sunlight and heat sources.
- Store the product and accessories exclusively in their original packaging.

6. Installation

Personnel
Skilled technical personnel - pressure equipment and systems (see section “2.3 Target group and personnel” on page 8)

6.1 Warning notices

DANGER	Sudden escape of pressurized fluids
	There is a danger of death or serious personal injury resulting from contact with fast or suddenly escaping fluids or through bursting system parts.
	<ul style="list-style-type: none"> • Before starting work, depressurize the pressurized system and secure it against unintentional pressurization. • Assemble all pipes and hoses free of mechanical stress.
NOTICE	Mechanical damage
	Connecting more than 3 products will overload the wall bracket and can result in deformation of the wall bracket and connected components.
	<ul style="list-style-type: none"> • Use a wall bracket for mounting a maximum of three connected filter products.

6.2 Preparation work

Prerequisites		
Tools	Material	Protective equipment
<ul style="list-style-type: none"> Screwdriver – PH1 Pozidriv head 	<ul style="list-style-type: none"> Additional installation and operating manuals for accessories used Sealing material such as Teflon tape (EN 837-2) Leak detector spray 	

Preparation work	
1.	Remove the plugs from the following threads: <ul style="list-style-type: none"> Inlet and outlet on the housing head Condensate drain at the bottom of the housing
2.	Depressurize the pipeline system or relevant pipe section.
3.	Pipes must be free from contamination and corrosion. <ul style="list-style-type: none"> → Check the pipe threads for damage. → Immediately replace faulty pipes.
4.	Design the condensate drain in such a way that no fluid or condensate can escape into the area around the product. Convey the drained condensate into a legally compliant treatment system.

6.3 Positioning the filter

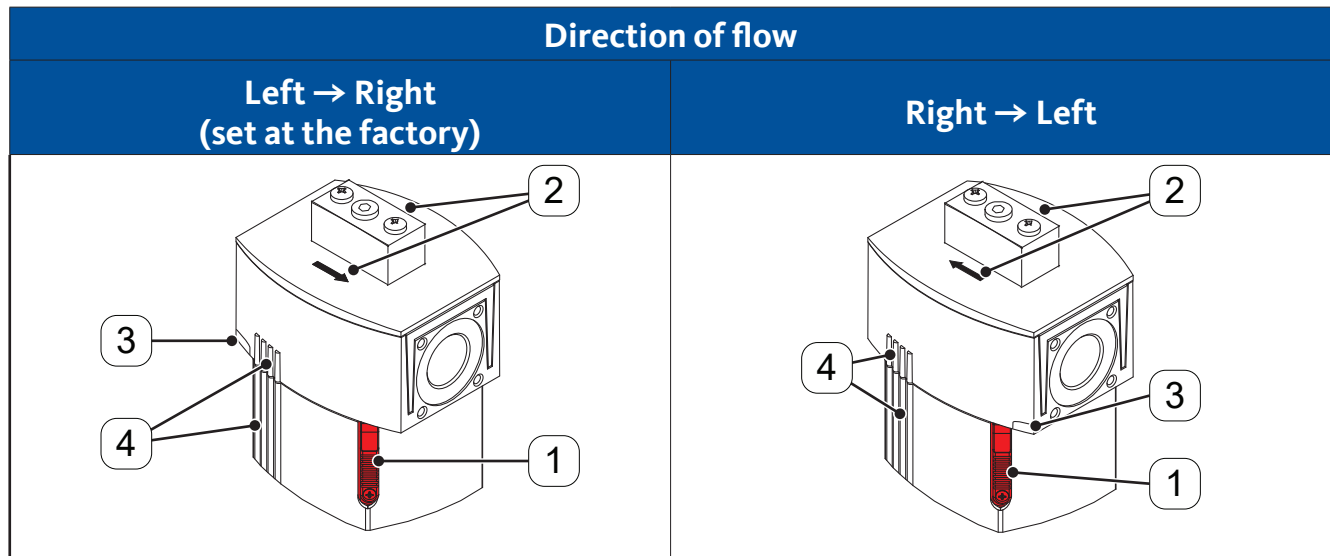

Align the direction of flow with the pipe's direction of flow and position the filter accordingly in the pipe:
The housing head and the housing feature a double-start trapezoidal thread.

- Screw the housing onto the housing head as far as it will go.
- Turn the housing back until the markings **[4]** on the housing and the housing head are aligned with each other.

The direction of flow through the product can be adjusted to that of the pipeline by turning the housing head 180°.

The direction of flow is indicated with arrows **[2]** and a recessed marking **[3]** on the housing head.

- In addition, make sure to position the safety slide **[1]** in such a way that it is accessible from the operator side (front side).

6.4 Installation work

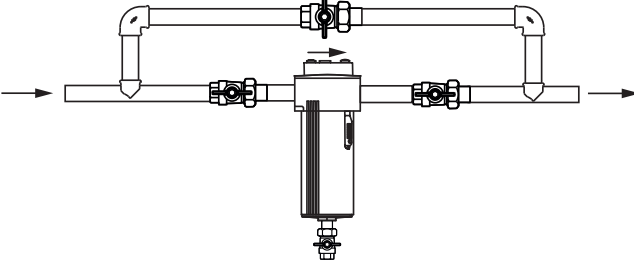
Figure	Description / explanation
	<ol style="list-style-type: none"> 1. Apply the sealing material, such as Teflon tape (EN 837-2) to the pipe ends. 2. Screw the pipe thread into the inlet on the housing head until the connection is solid and tight. 3. Screw the pipe thread into the outlet on the housing head until the connection is solid and tight.

6.5 Installing accessories

The steps for installing the various accessories are described in the corresponding applicable document (please refer to section “1.3 Other applicable documents” on page 5).

6.6 Concluding work

Concluding work	
1.	The housing must be correctly screwed into the housing head.
2.	The safety slide must have been slid all the way up.
3.	The locking screw must have been tightened.
4.	<p>Carry out a leak test after finishing all installation work.</p> <ul style="list-style-type: none"> → If there are any leaks, fix them and then seal the corresponding thread again. → If you hear a whistling sound, this means that the safety slide is not closed correctly. Slide the safety slide all the way up and tighten the locking screw.

7. Commissioning

Personnel
Skilled technical personnel specializing in pressure equipment and systems and trained electricians (please refer to section “2.3 Target group and personnel” on page 8)

7.1 Warning notices

DANGER	Sudden escape of pressurized fluids
	<p>There is a danger of death or serious personal injury resulting from contact with fast or suddenly escaping fluids or through bursting system parts.</p> <ul style="list-style-type: none"> • Before pressurization, check all system connections for leak tightness and tighten if necessary. • Slowly pressurize the system.

7.2 Commissioning work

Prerequisites		
Tools	Material	Protective equipment
<ul style="list-style-type: none"> • No tools required. 	<ul style="list-style-type: none"> • No material necessary. 	<ul style="list-style-type: none"> • No protective equipment required.

Preparation work	
1.	The product’s installation must have been completed.

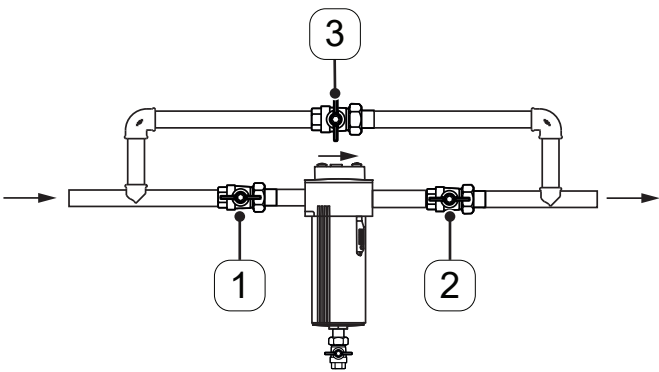
Commissioning work		
Figure		Description / explanation
Mechanically open	Automatic drainage	
		<ol style="list-style-type: none"> 1. Slowly open the shut-off valve [1] on the inlet side. 2. Slowly open the shut-off valve [2] on the outlet side. 3. Close the shutoff valve for the bypass valve [3], if any.

8. Maintenance

Personnel

Qualified service technicians (see section “2.3 Target group and personnel” on page 8)

8.1 Warning notices

DANGER	Sudden escape of pressurized fluids
	<p>There is a danger of death or serious personal injury resulting from contact with fast or suddenly escaping fluids or through bursting system parts.</p> <ul style="list-style-type: none"> Before starting work, depressurize the pressurized system and secure it against unintentional pressurization.



8.2 Maintenance plan

Maintenance work	Interval
Cleaning work	At regular intervals, depending on contamination
Visual inspection	Weekly
Replace the cartridge	For details, see section “4.1 Operating parameters” on page 23.
Leak test	At the end of all installation, maintenance, and servicing work on the product
Check the inside of the housing for damage and corrosion	Every time you replace the cartridge

8.3 Maintenance work

8.3.1 Cleaning

8.3.1.1 Warning notices

CAUTION	Personal injury caused by the improper use of cleaning agents
	<p>Improper use of cleaning agents may result in minor injuries and damage to health.</p> <ul style="list-style-type: none"> • Use personal protective equipment. • Use cleaning agents in accordance with the manufacturer’s instructions.
NOTICE	Observe all local hygiene regulations
	In addition to the cleaning instructions listed, any regionally applicable or company-specific hygiene regulations must be observed.

8.3.1.2 Cleaning work

Prerequisites		
Tools	Material	Protective equipment
<ul style="list-style-type: none"> • No tools required. 	<ul style="list-style-type: none"> • Mild cleaning agent • Cotton cloth or disposable cloth 	

Cleaning work	
1.	Spray cleaning agent onto an unused cotton cloth or disposable cloth until it is damp (not wet).
2.	Rub over the entire component
3.	Finally, dry the component with a clean cloth or let it air-dry.

8.4 Replacing the cartridge

Prerequisites		
Tools	Material	Protective equipment
<ul style="list-style-type: none"> Screwdriver – PH1 Pozidriv head 	<ul style="list-style-type: none"> New cartridge 	

Preparation work	
1.	Open the shutoff valve for the bypass valve, if any.

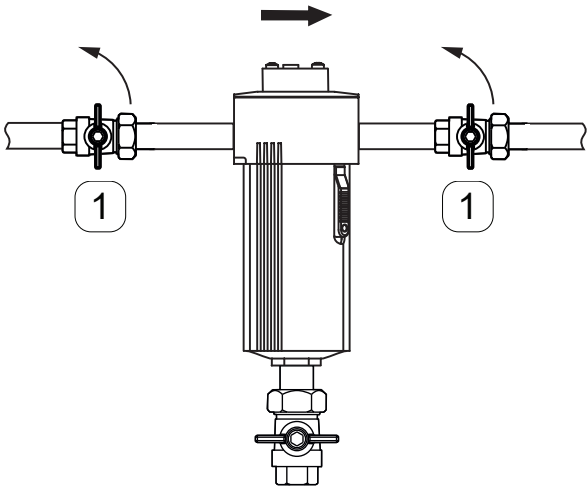
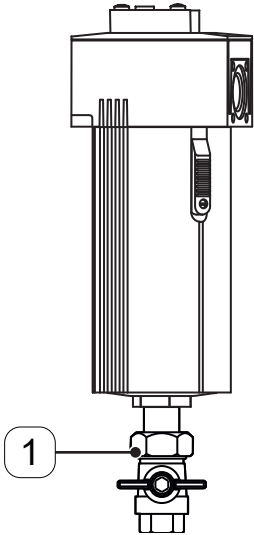
Replacing the cartridge	
Figure	Description / explanation
	<ol style="list-style-type: none"> 1. Close the shut-off valves [1] upstream and downstream of the filter or relevant system section.
	<ol style="list-style-type: none"> 2. Relieve the pressure in the filter. → Carefully open the manual drain. 3. Loosen the union nut [1]. 4. Pull the manual drain downwards.

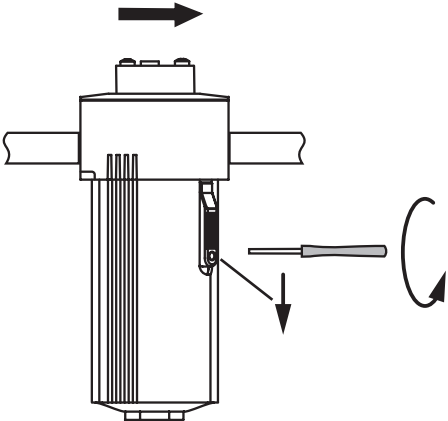
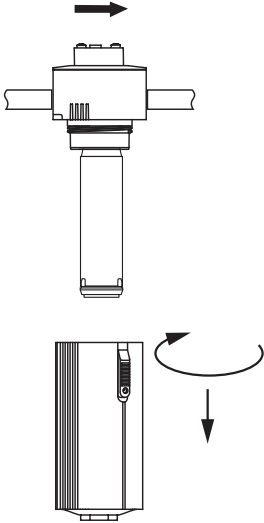
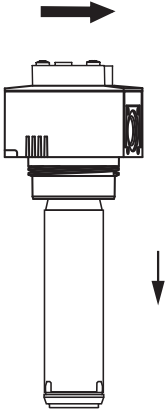
Replacing the cartridge	
Figure	Description / explanation
	<ol style="list-style-type: none"> 5. Loosen the locking screw on the safety slide. 6. Slide the safety slide down.
	<ol style="list-style-type: none"> 7. Unscrew the housing. 8. Remove the housing downwards.
	<ol style="list-style-type: none"> 9. Pull the used cartridge down and out of the housing head.

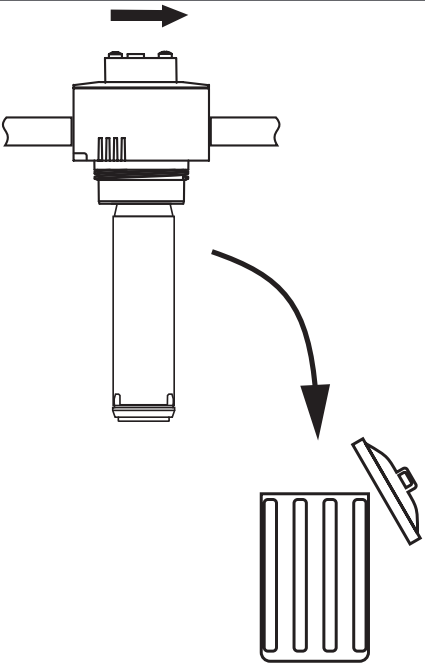
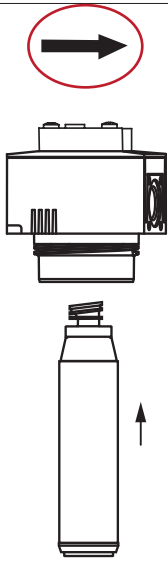
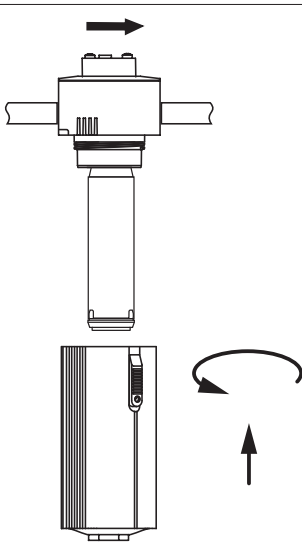
Replacing the cartridge	
Figure	Description / explanation
	<p>10. Dispose of the cartridge appropriately in accordance with all applicable local regulations. → (see section “11. Disposal” on page 43)</p>
	<p>11. Insert the new cartridge into the housing head. → When doing so, make sure to pay attention to the product’s direction of flow.</p>
	<p>12. Screw the housing onto the housing head. → Ensure that the safety slide points forward.</p>

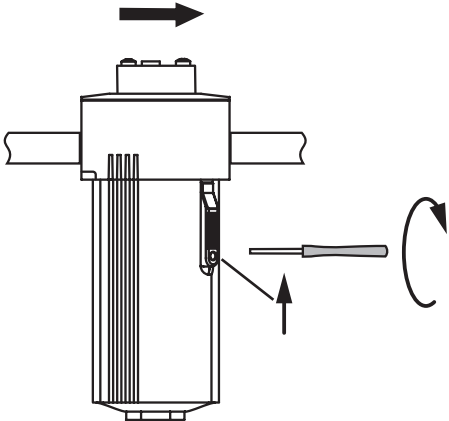
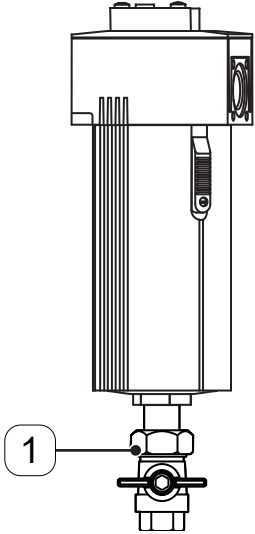
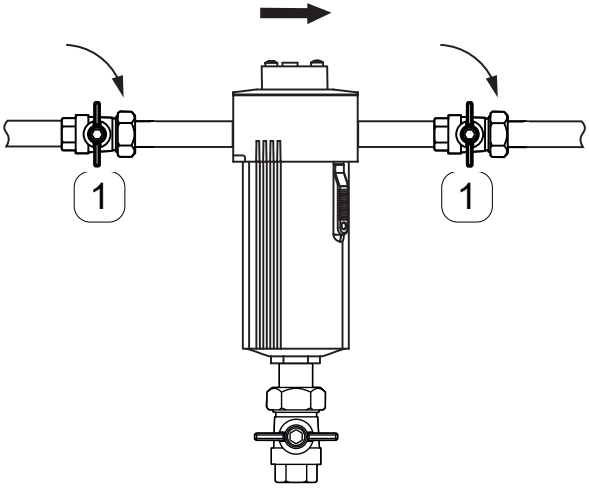
Replacing the cartridge	
Figure	Description / explanation
 <p>The diagram shows a top-down view of the filter housing. A black arrow points to the right above the housing. A safety slide is shown being moved upwards, indicated by a curved arrow. A screwdriver is shown tightening a locking screw on the side of the safety slide, also indicated by a curved arrow.</p>	<p>13. Slide the safety slide up.</p> <p>14. Tighten the locking screw on the safety slide.</p>
 <p>The diagram shows a side view of the filter housing. A manual drain is connected to the side. A union nut at the bottom is labeled with a circled '1'.</p>	<p>15. Connect the manual drain.</p> <p>16. Tighten the union nut [1] (max. 10 Nm (7.4 ft-lb)).</p>
 <p>The diagram shows a front view of the filter housing. Two shut-off valves on the side are labeled with circled '1's. Arrows indicate they should be turned clockwise to close. A black arrow points to the right above the housing.</p>	<p>17. Close the manual drain.</p> <p>18. Slowly open the shut-off valves [1] upstream and downstream of the filter or relevant system section.</p>

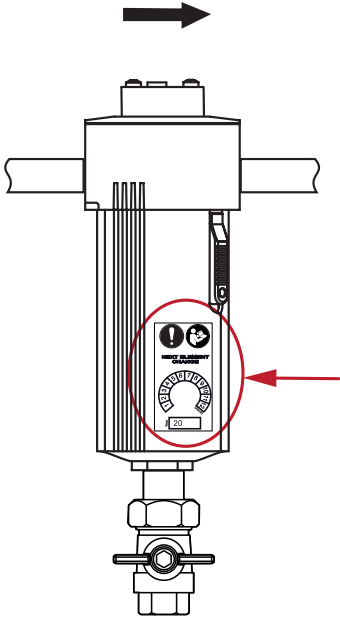
Replacing the cartridge	
Figure	Description / explanation
	<p>19. Affix the new maintenance sticker to the housing.</p> <p>20. Mark the next maintenance date.</p>

Concluding work	
1.	Close the shutoff valve for the bypass valve, if any.
2.	During pressurization, check all system connections for leaks and tighten them as necessary.
3.	Slowly pressurize the system.

8.4.1 Visual inspection

During the visual inspection of the product, check all components for mechanical damage and corrosion. Replace damaged components immediately.

9. Removal from service

Personnel	
Qualified service technicians (see section “2.3 Target group and personnel” on page 8)	

9.1 Warning notices

DANGER	Sudden escape of pressurized fluids
	<p>There is a danger of death or serious personal injury resulting from contact with fast or suddenly escaping fluids or through bursting system parts.</p> <ul style="list-style-type: none"> Before starting work, depressurize the pressurized system and secure it against unintentional pressurization.

9.2 Removal from service

Prerequisites		
Tools	Material	Protective equipment
<ul style="list-style-type: none"> No tools required. 	<ul style="list-style-type: none"> No material necessary 	

Preparation work	
1.	Open the shutoff valve for the bypass valve, if any.

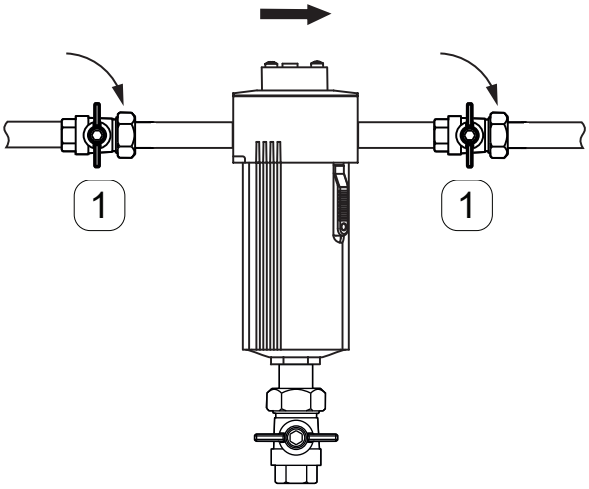
Figure	Description / explanation
	<ol style="list-style-type: none"> Close the shut-off valves [1] upstream and downstream of the filter or relevant system section. Relieve the pressure in the filter. <ul style="list-style-type: none"> → Carefully open the manual drain.

10. Disassembly

Personnel	
Qualified service technicians (see section “2.3 Target group and personnel” on page 8)	

10.1 Warning notices

DANGER	Sudden escape of pressurized fluids
	<p>There is a danger of death or serious personal injury resulting from contact with fast or suddenly escaping fluids or through bursting system parts.</p> <ul style="list-style-type: none"> Before starting work, depressurize the pressurized system and secure it against unintentional pressurization.

10.2 Disassembly steps

Prerequisites		
Tools	Material	Protective equipment
<ul style="list-style-type: none"> Screwdriver – PH1 Pozidriv head 	<ul style="list-style-type: none"> No material necessary 	

Preparation work	
1.	The product must have been fully removed from service and must be depressurized.

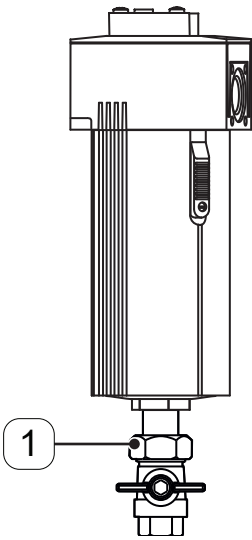
Disassembly	
Figure	Description / explanation
	<ol style="list-style-type: none"> Loosen the union nut [1]. Pull the manual drain downwards.

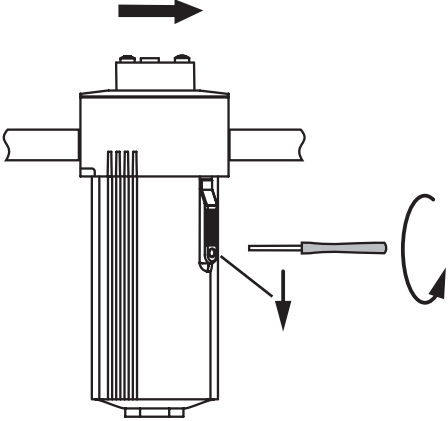
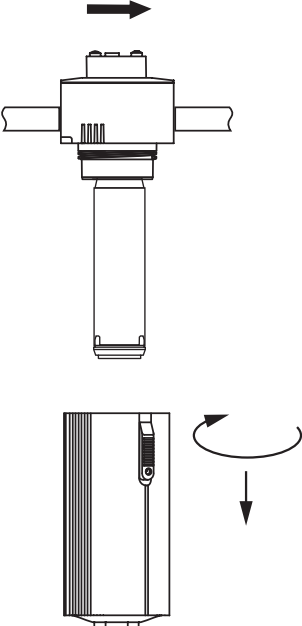
Disassembly	
Figure	Description / explanation
	<ol style="list-style-type: none"> 3. Loosen the locking screw on the safety slide. 4. Slide the safety slide down.
	<ol style="list-style-type: none"> 5. Unscrew the housing. 6. Remove the housing downwards. 7. Remove the cartridge. 8. Remove the housing head from the pipe and seal off the ends of the pipe appropriately. 9. Dispose of the components properly.

11. Disposal

The product and accessories must be properly disposed of at the end of their useful life, e.g., by a specialized company. Materials such as glass, plastics and some chemical compounds are mostly recoverable, reusable or recyclable.

11.1 Warning notices

NOTICE	Improper disposal
	<p>The improper disposal of parts, components, operating and auxiliary materials, and cleaning agents can cause environmental damage.</p> <ul style="list-style-type: none"> • Dispose of all components, parts, operating and auxiliary materials as well as cleaning agents professionally and in accordance with all locally applicable legal requirements and regulations. • In case of doubt, consult regional disposal companies before disposal.

11.2 Disposal of components

Prerequisites	
1.	The product and the accessories have been taken out of operation and disassembled.
2.	The product and the accessories have been cleaned and any fluid residue has been removed from them.

12. Spare parts and accessories

12.1 Spare parts

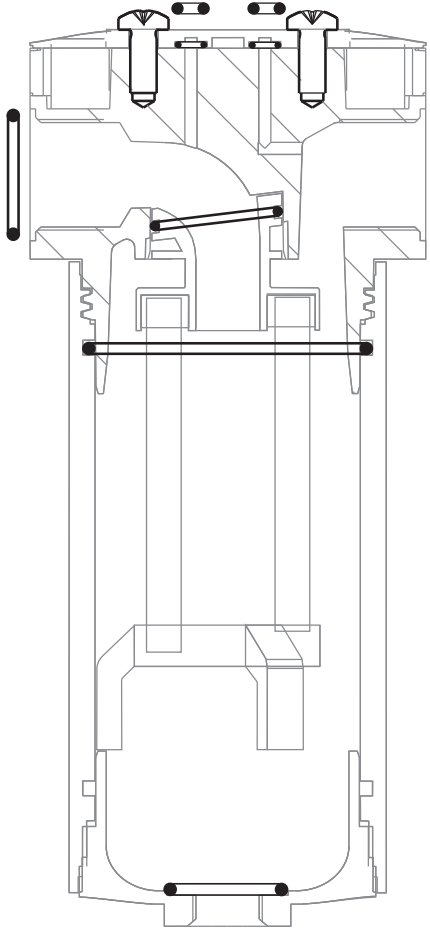
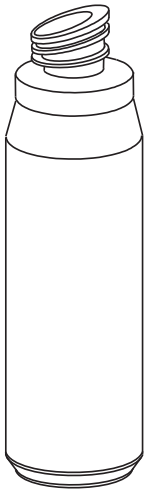
Figure	Description / explanation	Material no.
	O-ring set for S055	4026562
	O-ring set for M010X	4026563
	O-ring set for M018	4026564
	Cartridge	4009180
	Cartridge	4009181
	Cartridge	4009182

12.2 Accessories

Figure	Description / explanation	Material no.
	Oil test indicator with adapter	4008728
	Replacement tube for oil test indicator	4025989
	Wall bracket for S055	4003328
	Wall bracket for M010X	4003329
	Wall bracket for M018	4003330
	Adapter for oil test indicator S055	4008713
	Adapter for oil test indicator M010X	4008725
	Adapter for oil test indicator M018	4008726
	Connection set [X] for S055	4003332

Figure	Description / explanation	Material no.
	<p>Connection set [X] for M010X</p>	<p>4003333</p>
	<p>Connection set [X] for M018</p>	<p>4003334</p>
	<p>Manual drain</p>	<p>2000039</p>

13. Troubleshooting

Error or fault pattern	Possible causes	Troubleshooting
Inadequate filtration performance	Load too high, intermittent load	<ul style="list-style-type: none"> • Change operating method • Avoid pressure surges • Comply with the specified operating parameters, in particular during start-up
	Non-functional condensate drain	<ul style="list-style-type: none"> • Check the condensate drain and replace if necessary
	Incorrect dimensioning	<ul style="list-style-type: none"> • Replace the current filter with an adequately sized filter
	Cartridge installed incorrectly	<ul style="list-style-type: none"> • Check the direction of flow of the pipe and the cartridge
	O-ring was damaged during installation	<ul style="list-style-type: none"> • Replace the cartridge and O-ring
High pressure differential	Incorrect dimensioning	<ul style="list-style-type: none"> • Replace the current filter with an adequately sized filter
	High level of contamination	<ul style="list-style-type: none"> • Shorten the maintenance interval for the upstream filters • Check whether filtration in stages is required
	Ruined cartridge	<ul style="list-style-type: none"> • Check whether changing the operating method or filtration in stages is required
Leaks	Aging of seals	<ul style="list-style-type: none"> • Replace seals
	Mechanical damage	<ul style="list-style-type: none"> • Send in filter for repairs or replace with a new one

14. Appendices

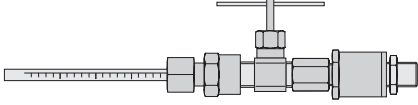
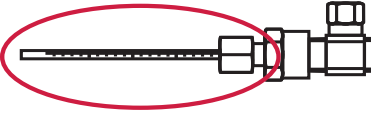
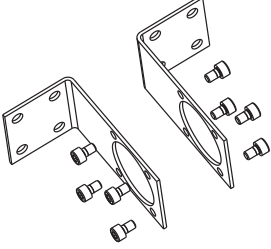
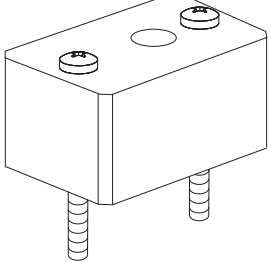
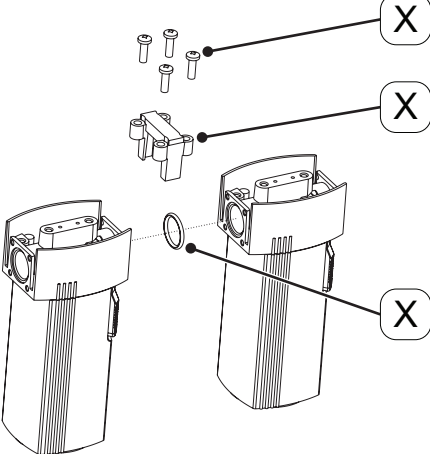
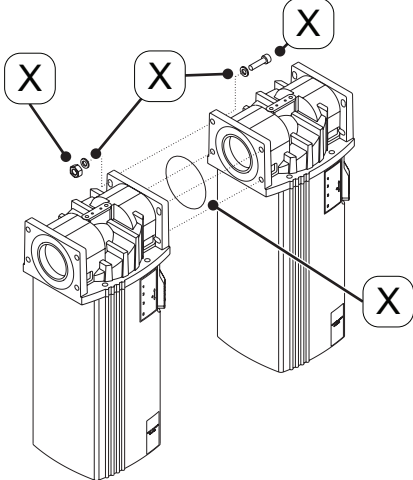
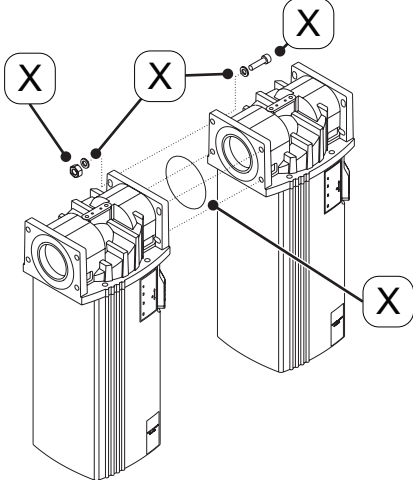
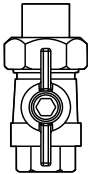
14.1 Manufacturer declaration

BEKO TECHNOLOGIES GMBH
Im Taubental 7
41468 Neuss

GERMANY

Tel: +49 2131 988-0
ww.beko-technologies.com



Herstellererklärung

Wir erklären hiermit, dass die nachfolgend bezeichneten Produkte, in den von uns gelieferten Ausführungen gemäß Druckgeräterichtlinie 2014/68/EU Artikel 4 Absatz 3 in Übereinstimmung mit der geltenden guten Ingenieurpraxis ausgelegt und hergestellt werden.

Produktbezeichnung:	Behälter für Gewindefilter
Typbezeichnung:	CLEARPOINT®
Baugröße:	S040, S045, S050, S055, S075, S100, M010, M012, M015, M018
Max. Betriebsdruck:	16 bar (ü)

Beschreibung der Druckgeräte: Druckgeräte für Fluide der Gruppe 2

Druckgeräte nach Artikel 4 Absatz 3 der Druckgeräterichtlinie 2014/68/EU dürfen nicht die in Artikel 19 genannte CE-Kennzeichnung tragen.

Die Behälter wurden einer hydraulischen Druckprüfung mit 23 bar (ü), und einer Dichtheitsprüfung mit dem Medium Druckluft, bei 7,0 bar (ü) unterzogen. Bei den durchgeführten Prüfungen zeigten sich keine Mängel.

Neuss, 26.02.2020

BEKO TECHNOLOGIES GMBH

A handwritten signature in black ink, appearing to read "Christian Riedel".

i.V. Christian Riedel
Leiter Qualitätsmanagement International

BEKO TECHNOLOGIES GMBH
Im Taubental 7
41468 Neuss

GERMANY

Phone: +49 2131 988-0
www.beko-technologies.com



Manufacturer declaration

We hereby declare that the following products have been designed and manufactured in the versions delivered by us according to Pressure Directive 2014/68/EU, article 4 paragraph 3 and in accordance with good general engineering practice.

Product designation:	Container for threaded filter
Type designation:	CLEARPOINT®
Size:	S040, S045, S050, S055, S075, S100, M010, M012, M015, M018
Max. Operating Pressure:	16 bar(g)
Description of pressure equipment:	Pressure equipment for group 2 fluids

Pressure equipment according to article 4 paragraph 3 of Pressure Directive 2014/68/EU may not bear the CE mark indicated in article 19.

Containers are subject to a hydraulic pressure test at 23 bar(g) and a leak test using compressed air as the medium at 7.0 bar(g). No defects were found during the completed tests.

Neuss, 2/26/2020

BEKO TECHNOLOGIES GMBH

i.V. Christian Riedel
Manager Quality Management

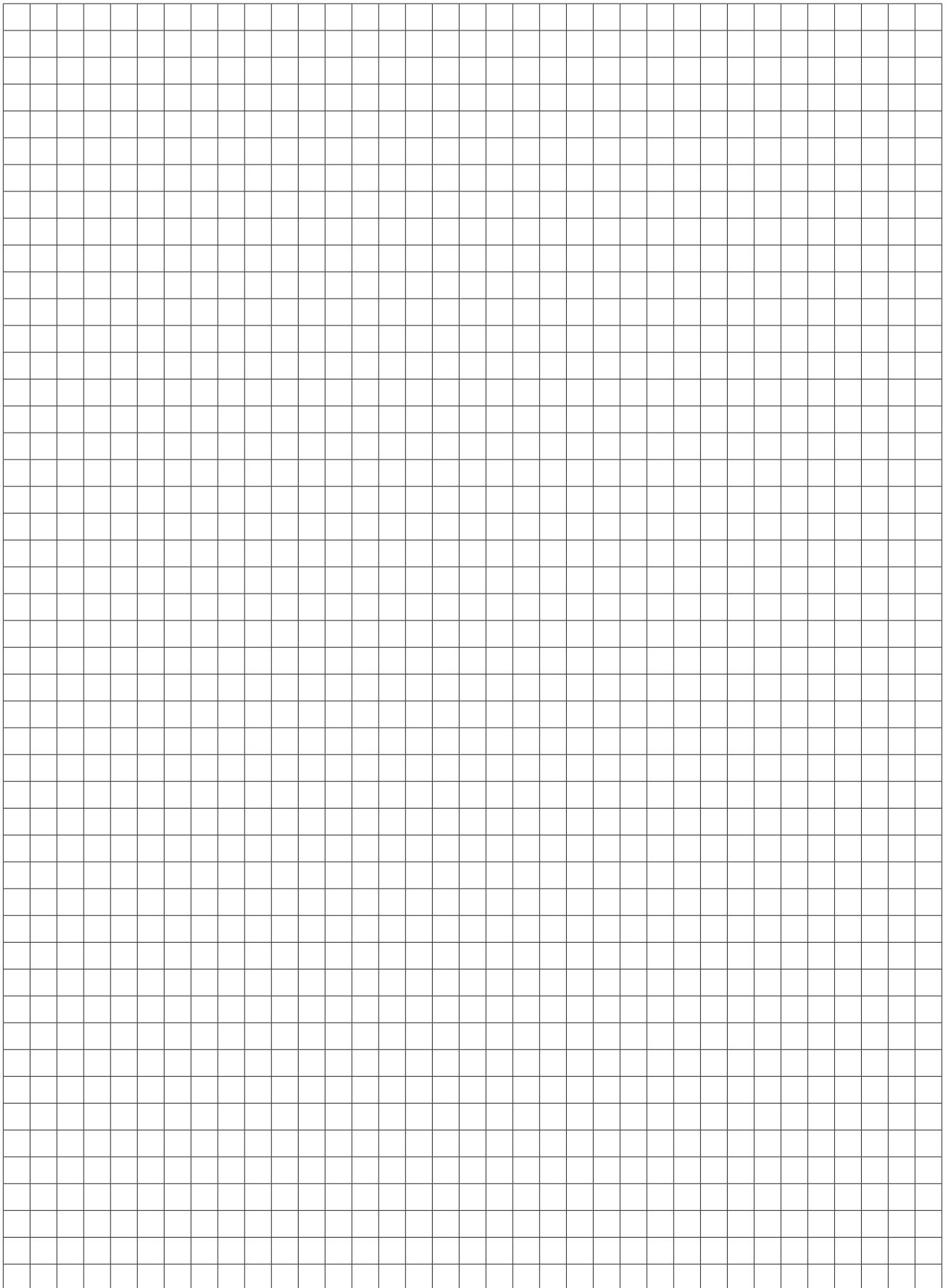

BEKO TECHNOLOGIES GmbH

Im Taubental 7
 D - 41468 Neuss
 Tel. +49 2131 988 0
 Fax +49 2131 988 900
 info@beko-technologies.com
 service-eu@beko-technologies.com

DE**BEKO TECHNOLOGIES LTD.**

Unit 11-12 Moons Park
 Burnt Meadow Road
 North Moons Moat
 Redditch, Worcs, B98 9PA
 Tel. +44 1527 575 778
 info@beko-technologies.co.uk

GB**BEKO TECHNOLOGIES S.à.r.l.**

Zone Industrielle
 1 Rue des Frères Rémy
 F - 57200 Sarreguemines
 Tél. +33 387 283 800
 info@beko-technologies.fr
 service@beko-technologies.fr

FR**BEKO TECHNOLOGIES B.V.**

Veenen 12
 NL - 4703 RB Roosendaal
 Tel. +31 165 320 300
 benelux@beko-technologies.com
 service-bnl@beko-technologies.com

NL**BEKO TECHNOLOGIES (Shanghai) Co. Ltd.**

Rm.715 Building C, VANTONE Center
 No.333 Suhong Rd.Minhang District
 201106 Shanghai
 Tel. +86 (21) 50815885
 info.cn@beko-technologies.cn
 service1@beko.cn

CN**BEKO TECHNOLOGIES s.r.o.**

Na Pankráci 26/322
 CZ - 140 00 Praha 4
 Tel. +420 24 14 14 717 /
 +420 24 14 09 333
 info@beko-technologies.cz

CZ**BEKO Tecnológica España S.L.**

Torruella i Urpina 37-42, nave 6
 E - 08758 Cervelló
 Tel. +34 93 632 76 68
 Mobil +34 610 780 639
 info.es@beko-technologies.es

ES**BEKO TECHNOLOGIES LIMITED**

Room 2608B, Skyline Tower,
 No. 39 Wang Kwong Road
 Kwloon Bay Kwloon, Hong Kong
 Tel. +852 2321 0192
 Raymond.Low@beko-technologies.com

HK**BEKO TECHNOLOGIES INDIA Pvt. Ltd.**

Plot No.43/1 CIEEP Gandhi Nagar
 Balanagar Hyderabad
 IN - 500 037
 Tel. +91 40 23080275 /
 +91 40 23081107
 Madhusudan.Masur@bekoindia.com
 service@bekoindia.com

IN**BEKO TECHNOLOGIES S.r.l**

Via Peano 86/88
 I - 10040 Leinì (TO)
 Tel. +39 011 4500 576
 Fax +39 0114 500 578
 info.it@beko-technologies.com
 service.it@beko-technologies.com

IT**BEKO TECHNOLOGIES K.K**

KEIHIN THINK Building 8 Floor
 1-1 Minamiwatarida-machi
 Kawasaki-ku, Kawasaki-shi
 JP - 210-0855
 Tel. +81 44 328 76 01
 info@beko-technologies.jp

JP**BEKO TECHNOLOGIES Sp. z o.o.**

ul. Pańska 73
 PL - 00-834 Warszawa
 Tel. +48 22 314 75 40
 info.pl@beko-technologies.pl

PL**BEKO TECHNOLOGIES S. de R.L. de C.**

BEKO Technologies, S de R.L. de C.V.
 Blvd. Vito Alessio Robles 4602 Bodega 10
 Zona Industrial
 Saltillo, Coahuila, 25107
 Mexico
 Tel. +52(844) 218-1979
 informacion@beko-technologies.com

MX**BEKO TECHNOLOGIES, CORP.**

900 Great Southwest Pkwy SW
 Atlanta, GA 30336
 USA
 Tel. +1 404 924-6900
 beko@bekousa.com

US