



Installation and operating manual

Compressed air refrigeration dryer DRYPOINT® RA III

- | | |
|--------|-----------|
| > 1080 | > 1080 WC |
| > 1300 | > 1300 WC |
| > 1490 | > 1490 WC |
| > 1900 | > 1900 WC |
| > 2400 | > 2400 WC |
| > 3000 | > 3000 WC |

■ Table of Contents

1.	Notes	6
1.1	Contact	6
1.2	Information on the installation and operating manual	7
1.3	Other applicable documents	7
2.	Safety	8
2.1	Use	8
2.1.1	Intended use	8
2.1.2	Reasonably foreseeable incorrect use	9
2.2	Operating company responsibility	9
2.3	Target group and personnel	10
2.4	Explanation of the symbols	12
2.5	Safety instructions and warning notices	13
2.5.1	General applicable safety instructions	13
2.5.2	Safe operation	13
2.5.3	Pressurised systems	14
2.5.4	Electric voltage	14
2.5.5	Transport and storage	15
2.5.6	Installation	15
2.5.7	Maintenance	16
2.5.8	Handling hazardous substances	17
2.5.9	Spare parts, accessories or materials	17
2.6	Warning notices	18
3.	Product information	19
3.1	Product overview	19
3.1.1	DRYPOINT® RA III 1080, 1300	19
3.1.2	DRYPOINT® RA III 1080, 1300 water-cooled	20
3.1.3	DRYPOINT® RA III 1490, 1900	21
3.1.4	DRYPOINT® RA III 1490, 1900 water-cooled	22
3.1.5	DRYPOINT® RA III 2400, 3000	23
3.1.6	DRYPOINT® RA III 2400, 3000 water-cooled	24
3.2	Function description	25
3.2.1	Flow diagram, air-cooled models	25
3.2.2	Flow diagram, water-cooled models	26
3.2.3	Compressed air flow	26
3.2.4	Refrigerating cycle	26

3.3	Type plate	27
3.3.1	DRYPOINT® RA III type plate	27
3.4	Scope of delivery	28
4.	Technical data	29
4.1	Operating parameters	29
4.1.1	DRYPOINT® RA III 1080 ... 1300.....	30
4.1.2	DRYPOINT® RA III 1490 ... 1900.....	31
4.1.3	DRYPOINT® RA III 2400 ... 3000.....	32
4.1.4	DRYPOINT® RA III 1080 ... 1300 @60Hz.....	33
4.1.5	DRYPOINT® RA III 1490 ... 3000 @60Hz.....	34
4.2	Correction factors	35
4.3	Cooling water parameters, water-cooled models.....	36
4.4	Storage parameters	37
4.5	Materials.....	38
4.6	Dimensions	39
4.6.1	DRYPOINT® RA III 1080 ... 1300.....	39
4.6.2	DRYPOINT® RA III 1490 ... 3000.....	40
4.6.3	DRYPOINT® RA III 1490 ... 3000 water-cooled.....	41
4.7	Connections.....	42
4.7.1	DRYPOINT® RA III 1080 ... 1300.....	42
4.7.2	DRYPOINT® RA III 1490 ... 3000.....	43
4.8	Assembly conditions	44
4.8.1	Minimum distance from adjacent structures.....	45
5.	Transport and storage.....	46
5.1	Warning notices.....	46
5.2	Transport	47
5.3	Storage.....	48
6.	Assembly.....	49
6.1	Warning notices.....	49
6.2	Assembly.....	50
7.	Electrical installation	51
7.1	Warning notices.....	51

7.2	Connections	53
7.2.1	External power supply.....	54
7.2.2	WARNING / ALARM digital output.....	54
7.2.3	STANDBY – RUNNING digital output	55
7.2.4	DEW POINT TEMPERATURE analogue output	56
7.2.5	Remote START-STOP digital input.....	56
7.2.6	Remote RESET digital input.....	57
7.2.7	USB memory stick for data log storage	58
7.2.8	Remote management, Modbus RTU data signal	58
8.	Commissioning.....	59
8.1	Warning notices	59
8.2	Initial commissioning.....	60
9.	Operation	62
9.1	Warning notices	62
9.2	Daily operating checks.....	62
9.3	Overview of User Interface after power ON	63
9.4	Operate on the User Interface.....	63
9.4.1	Normal running status.....	64
9.4.2	Stopping and starting.....	65
9.4.3	Condensate drain test.....	66
9.4.4	Actual process values, data logger, data recording	67
9.4.5	WARNING status	71
9.4.6	ALARM status	73
9.4.7	ALARM history.....	75
9.4.8	Remote mode.....	77
9.4.9	Operating hours and maintenance timer.....	78
9.4.10	System settings and automatic start/stop weekly timer.....	79
9.4.11	Device spare parts list.....	81
9.4.12	User parameters.....	82
9.4.13	Modbus function	87
10.	Maintenance.....	88
10.1	Warning notices	88
10.2	Maintenance	90
10.2.1	Maintenance timer reset.....	91
11.	Adjustments	92
11.1	Warning notices	92
11.2	Adjustment.....	93
11.2.1	Adjustment of hot gas by-pass valve.....	94
11.2.2	Adjustment of cooling water regulating valve, water-cooled models.....	96

12. Spare parts	98
12.1 Order information	98
12.2 Spare parts	99
13. Decommissioning	100
13.1 Warning notices.....	100
13.2 Decommissioning	101
14. Disassembly	102
14.1 Warning notices.....	102
14.2 Disassembly	104
15. Disposal.....	105
15.1 Warning notices.....	105
15.2 Disposal of materials and components	106
16. Troubleshooting.....	108
16.1 Warnings and alarms	109
16.1.1 Clearing a WARNING.....	109
16.1.2 Clearing an ALARM	112
16.2 Specific malfunctions	117
17. Notes.....	122

1. Notes

This documentation contains the necessary steps for using the product and accessories.

1.1 Contact

Manufacturer	Customer service and tools
<p>BEKO TECHNOLOGIES GmbH</p> <p>Im Taubental 7 41468 Neuss Tel. + 49 2131 988 - 1000 info@beko-technologies.com www.beko-technologies.com</p>	<p>BEKO TECHNOLOGIES GmbH</p> <p>Im Taubental 7 41468 Neuss Tel. + 49 2131 988 - 1000 service-eu@beko-technologies.com www.beko-technologies.com</p>

INFORMATION	Country-specific manufacturer representative
	<p>Contact the country-specific manufacturer representative using the address listed in the address section on the rear cover or contact form on the manufacturer's website.</p>

1.2 Information on the installation and operating manual

INFORMATION	Copyright protection
	<p>The contents of the installation and operating manual in the form of text, figures, illustrations, photographs, technical drawings, diagrams and other representations are protected by manufacturer copyright. The distribution and duplication of this document, exploitation and disclosure of its contents are prohibited unless expressly authorised.</p>

Publication date	Revision	Version	Reason for amendment	Amendment scope
29 May 2025	01	00	Correction	7.2 Connections

The installation and operating manual was originally written in ENGLISH.

The installation and operating manual, hereafter referred to as the manual, must be kept close to the product and in a legible state.

The manual must be handed over along with the product if it is sold or transferred.

NOTE	Follow the instructions given in the manual
	<p>This manual contains the basic information required for safe operation of the product and must be read before performing any actions. Otherwise personal and material hazards and malfunction and device failure are possible.</p>

1.3 Other applicable documents

- Refrigerant fluid safety data sheet
- **BEKOMAT®** Installation and operating manual
- Wiring diagrams
- Modbus configuration description

2. Safety

2.1 Use

2.1.1 Intended use

The **DRYPOINT® RA III**, hereafter product / device, is a compressed-air refrigeration dryer used to separate the moisture in compressed air, where compressed air does not treat foodstuffs and is not used for breathing purposes.

The product is intended only for the separation of moisture in compressed air. Using this product in ways not specified in this manual is considered unintended and may pose risks to human safety and environmental health.

The following must be noted for intended use:

- Read and follow the manual.
- Use the product and accessories within the operating parameters given in the technical data and the agreed delivery conditions.
- Use the product and accessories with media which are free from caustic, aggressive, corrosive, toxic, flammable, oxidising or inorganic components. An analysis must be carried out in cases of doubt.
- Use the product and accessories in areas which are free from toxic and corrosive chemicals and gases.
- Use the product and accessories within piping system designed for the technical data with appropriate connections, pipe diameters and assembly clearances.
- Use the product and accessories outside potentially explosive atmospheres.
- Use the product and accessories away from direct solar radiation and heat sources and areas subject to frost.
- Combine the product and accessories with the products and components named and recommended by **BEKO TECHNOLOGIES** in the manual.
- Comply with the prescribed maintenance schedules.

Before using the product and accessories, the operating company must make sure that all conditions and prerequisites for intended use are met.

The product and accessories have been exclusively designed for stationary use in a commercial or industrial area. Assembly, installation, operation, maintenance, disassembly and disposal work described may only be performed by qualified skilled technical personnel.

2.1.2 Reasonably foreseeable incorrect use

Reasonably foreseeable incorrect use is when the product or accessories are used in any other way than what described in section "2.1.1 Intended use" on page 8. Reasonably foreseeable incorrect use includes the use of the product or accessories in a manner unintended by the manufacturer or supplier but which may result from user behaviour.

Reasonably foreseeable incorrect use includes:

- Using treated air for foodstuffs or breathing purposes.
- Making any modifications, such as constructive and process-technology related works.
- Suspending, failure to comply or not applying existing or recommended safety equipment.

This list is not exhaustive since it cannot include all possible incorrect use. If the operating company is aware of any incorrect use of the product or accessories which are not listed here, the manufacturer must be informed immediately.

2.2 Operating company responsibility

To prevent accidents, incidents and adverse effects on the environment, the responsible operating company must ensure the following:

- Before all actions, check to ensure that the manual available belongs to the product.
- The product and accessories are used, serviced and repaired based on the intended use.
- The product and accessories are used with the recommended and fully operable safety equipment.
- Assembly, installation and maintenance work must be carried out by qualified skilled technical personnel.
- Personnel must have the necessary personal protective equipment available and use it.
- Suitable technical safety measures to comply with permissible operating parameters.
- Maintain the safety symbols and type plate on the product and accessories in a legible state. Replace damaged and illegible markings immediately.

2.3 Target group and personnel

This manual addresses the personnel listed below who are involved with work on the product or accessories.

INFORMATION	Personnel requirements
	Personnel may not perform any actions on the product or accessories if they are under the influence of drugs, medications, alcohol or other substances that may impair their awareness.

Operating personnel

Operating personnel are those who can operate the product and accessories safely based on product and accessories manual knowledge. Operating personnel can recognise possible malfunctions and dangerous situations independently and arrange for related measures.

Skilled technical personnel - transport and storage

Skilled technical personnel specialising in transport and storage have the training, professional experience, qualifications, and the necessary skills to safely perform product transport and storage actions. They can instruct, detect possible dangerous situations independently and implement measures to avoid danger. Their skills include experience with hoists, forklifts and lifting equipment and knowledge of local laws, standards and guidelines relating to transport and storage.

Skilled technical personnel – pressure equipment and systems

Skilled technical personnel specialising in pressure equipment and systems have the training, professional experience, qualifications and the necessary skills to safely perform pressurised fluid and system actions. They can instruct, detect possible dangerous situations independently and implement measures to avoid danger. Their skills include experience in using measuring and control equipment, and knowledge of local laws, standards and guidelines for pressurised systems.

Skilled technical personnel - refrigeration engineering

Skilled technical personnel specialising in refrigeration engineering have the training, professional experience, qualifications and the necessary skills to safely perform refrigerant fluid actions. They can instruct, detect possible dangerous situations independently and implement measures to avoid danger. Their skills include experience in handling refrigerant fluids, refrigerant circuits, measurement and control technology, and knowledge of local laws, standards and guidelines for refrigerant fluids technology.

Skilled technical personnel - electrical engineering













Skilled technical personnel specialising in electrical engineering have the training, professional experience, qualifications and the necessary skills to safely perform actions related to electricity. They can instruct, detect possible dangerous situations independently and implement measures to avoid danger. Their skills include experience in using electrical systems, measurement and control technology, and knowledge of local laws, standards and guidelines for electrical technology.

Skilled technical personnel – customer service

Skilled technical personnel specialising in customer service have the skills and qualifications mentioned above. Skilled technical personnel specialising in customer service must be authorised and have documented proof of training for working on the product.

2.4 Explanation of the symbols

The symbols used below indicate safety-relevant and important information which must be followed when handling the product and ensure safe and optimum operation.

Symbol	Description / explanation
	General warning symbol (danger, warning, caution)
	Danger: pressurised system
	Danger: electric voltage
	Warning: hot surfaces
	Follow the installation and operating manual
	General mandatory sign
	Wear safety footwear
	Use respiratory protection, class FFP 3 protection (particle-filtering half mask)
	Use self-contained respiratory protection
	Use protective gloves (cut-proof, liquid-resistant, chemicals-proof)
	Wear safety goggles with side shields
	General information

2.5 Safety instructions and warning notices

This section provides an overview of important safety aspects for personal protection, the safe and problem-free operation of the product and accessories.

The following sections list the dangers posed by this product and accessories even if used correctly. To minimise the risk of personal injury and damage to property and avoid dangerous situations, follow the safety instructions and warning notices in the other sections of this manual.

Basic warning notices and the necessary qualifications of skilled technical personnel are listed at the beginning of the "Warning notices" section.

Warning notices related to specific actions are printed directly before potentially hazardous procedures or sequences of actions.

2.5.1 General applicable safety instructions

- Before starting work, refer to the system's technical documentation and follow the operating instructions.
- Carry out a risk assessment before starting work on site (last minute risk assessment).
- Use suitable personal protective equipment (PPE) for work.
- Set up a safety area around the working area during installation, maintenance and repair work.
- Use existing plant-specific Lockout Tagout (LOTO) procedure for safe shutdown and isolation from energy hazards.

2.5.2 Safe operation

The following actions may result in serious personal injury or death:

- Commissioning and operation of the product and accessories outside the permissible limit values and operating parameters.
- Unauthorised interference and modifications of the product and accessories.

To guarantee safe operation of the product and accessories, follow these instructions:

- Observe the limits and operating parameters specified in the type plate and manual.
- Check whether the permissible operating parameters have been changed or restricted by accessories.
- Observe the assembly and ambient conditions.
- Comply with maintenance intervals.

2.5.3 Pressurised systems

The following may result in serious personal injury or death:

- Contact with fast or suddenly escaping fluids.
- Bursting system parts.
- Whipping movements of pressurised hoses and pipes during separation.

To safely handle pressurised systems, follow these instructions:

- Observe the following safety rules during work:
 1. Shut down the system or system section.
 2. Secure the system or system section against restarting.
 3. Reduce the pressure in the system or system sections to ambient pressure.
 4. e.g. by slowly releasing the pressure in a controlled manner via relief valves.
 5. Prevent pressure being re-applied.
- Check pressurised systems for safety, contamination and possible damage.
- Before pressurisation, check all system connections for leak tightness and tighten if necessary.
- Pressurise systems slowly.
- Avoid pressure blows and high differential pressures.
- Compensate any vibrations occurring in the pipe network by using vibration dampers.

2.5.4 Electric voltage

Contact with live components may result in serious personal injuries or death.

To safely handle live components, follow these instructions:

- Connect the product and accessories to the voltage supply only if they are undamaged.
- Comply with local applicable regulations and requirements during installation.
- Provide a circuit breaker in the power supply within easy reach of the product. The circuit breaker disconnects current-carrying conductors.
- Connect the protective conductor (earth connection) under regulations.
- Operate the product and accessories with the cover complete and closed and the electronics housing closed.
- Before starting work on the product:
 1. Disconnect.
 - Disconnect the product from all poles and sides.
 2. Secure against restarting.
 3. Determine the absence of voltage at all poles.
 - With suitable and permissible measuring device (e.g. voltage tester).
 4. Earth and short circuit.

2.5.5 Transport and storage

Incorrect transport or storage may result in personal injury or damage to property.

For safe transport and storage of the product and accessories, follow these instructions:

- Handle the packaging, product and accessories carefully.
- Transport and handle the packaged product and accessories according to the markings on the packaging (note lifting gear attachment points, the centre of gravity and alignment e.g. keep vertical, do not throw, etc.).
- Use means of transport and lifting equipment that is working properly.
- Comply with permissible storage parameters.
- Store the product and accessories outside areas exposed to direct sunlight and heat sources.

2.5.6 Installation

Incorrect assembly or electrical installation of the product and accessories may result in personal injury and damage to property and impair operation.

For safe assembly and electrical installation, follow these instructions:

- Assemble the product, parts, accessories and materials so they are free from mechanical stress.
- Check the plug-type connections for a correct fit.
- Avoid tripping risks by routing cables and hoses properly.
- Avoid mechanical strain on the cables.
- Fix and fasten hoses so they do not dangle.
- Install air inlet/outlet and drain lines as fixed pipes.

2.5.7 Maintenance

Improper performance of maintenance and repair work may result in serious personal injuries or death.

For safe maintenance and repair, follow these instructions:

- Before starting work, depressurise the product and accessories and secure them against unintentional pressurisation.
- Before starting work, disconnect the product and accessories and prevent them from being switched back ON unintentionally.
- The product contains fluorinated greenhouse refrigerant fluid. Observe the requirements indicated on the safety data sheet of the refrigerant fluid during maintenance, repair and emptying operations of the refrigerant circuit.
- Use materials approved for the respective application.
- Use suitable tools that are in proper working order.
- Use cleaned pipes and hoses that are free from dirt and corrosion.
- Never use abrasive or aggressive cleaning agents or solvents which could damage the outer coating (e.g. markings, type plate, corrosion protection, etc.).
- Never clean the product with hard or pointed implements.
- Use the specified materials and media for cleaning.
- Comply with statutory, local and in-house hygiene regulations.
- Pay attention to order and cleanliness during maintenance and repair work. Prevent contamination from entering the opened product and accessories. Store disassembled components and accessories directly in a safe place.
- After completing maintenance and repair work, remove the tools, cleaning agents, and parts that are no longer needed, from the work area.
- Dispose of product and accessories when cleaned and freed of any residue.
- Dispose of components, parts, operating and auxiliary materials and cleaning agents professionally and under local applicable regulations and standards.
- Dispose of electrical and electronic components using a specialist disposal company or return them to the manufacturer.
- Dispose of the refrigerant fluid under applicable national and local regulations and the requirements specified on the safety data sheet of the refrigerant fluid.

2.5.8 Handling hazardous substances

Contact with condensate containing substances which endanger health and the environment can pose a health hazard, causing irritation or damage to the eyes, skin and mucous membranes. Polluted condensate must be prevented from entering the sewerage system, waters or the ground.

To safely handle polluted condensate, follow these instructions:

- Use suitable protective equipment when handling condensate.
- Pick up and dispose of any leaking or spilled condensate under applicable regional laws and requirements.

The product contains fluorinated greenhouse refrigerant fluid. Improper handling of the refrigerant fluid can be harmful to health and cause damage to the environment.

To safely handle refrigerant fluid, follow these instructions:

- Use suitable protective equipment when handling refrigerant fluid. Self contained breathing apparatus is recommended, where unknown exposure may be expected, e.g. during maintenance, repair and dismantling work on refrigerant circuit.
- Pick up and dispose of the refrigerant fluid under national and local applicable regulations. Discharging large quantities of refrigerant into the atmosphere should be avoided.

2.5.9 Spare parts, accessories or materials

Using incorrect spare parts, accessories, materials, auxiliary and operating materials, may result in death or serious injury. Malfunction, device failure or material damage may occur.

- Use undamaged original parts, auxiliary and operating materials which are specified by the manufacturer to complete work.
- Use the materials approved for the related application and tools that are working properly.
- Use cleaned pipes that are free from dirt and corrosion.
- Use electrical components and materials that comply with local applicable specifications and regulations (standards, directives, etc.) for electrical safety.

2.6 Warning notices

Warning notices warn against dangers when handling the product and accessories.

To prevent accidents, personal injury and damage to property and impairments during operation, it is essential to comply with the warning notices.

Structural set up:

SIGNAL WORD	Type and source of danger
 Symbol	Possible consequences if the danger is ignored
	<ul style="list-style-type: none"> Measures to prevent the danger

Signal words:

DANGER

Imminent hazard

Consequences of non-compliance: Death or serious personal injury

WARNING

Imminent hazard

Consequences of non-compliance: Death or serious personal injuries are possible

CAUTION

Potential hazard

Consequences of non-compliance: Personal injuries or damage to property are possible

NOTE

Additional notes

Consequences of non-compliance: Damage to property, malfunction and device failures are possible. No hazard to people or endangerment of safe operation

3. Product information

3.1 Product overview

3.1.1 DRYPOINT® RA III 1080, 1300

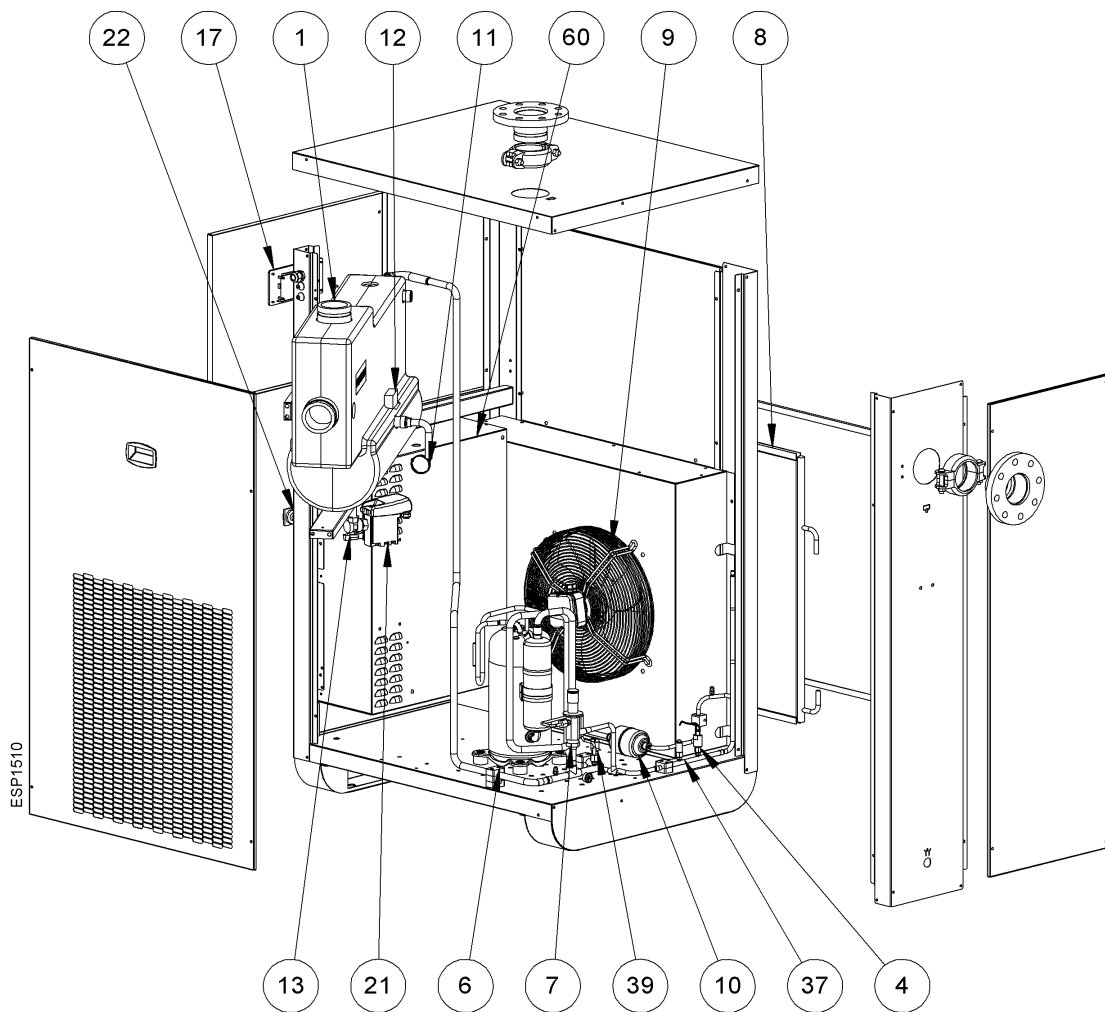

Pos. No.	Description / explanation
[1]	Heat exchanger
[4]	High pressure switch HPS
[6]	Refrigerant compressor
[7]	Hot gas by-pass valve
[8]	Condenser
[9]	Cooling fan
[10]	Refrigerant fluid filter
[11]	Capillary tube

Pos. No.	Description / explanation
[12]	Temperature probe BT1
[13]	Condensate drain service valve
[17]	User Interface
[21]	Condensate drain
[22]	ON-OFF switch
[37]	Pressure transducer BHP
[39]	Pressure transducer BLP
[60]	Electrical box

3.1.2 DRYPOINT® RA III 1080, 1300 water-cooled

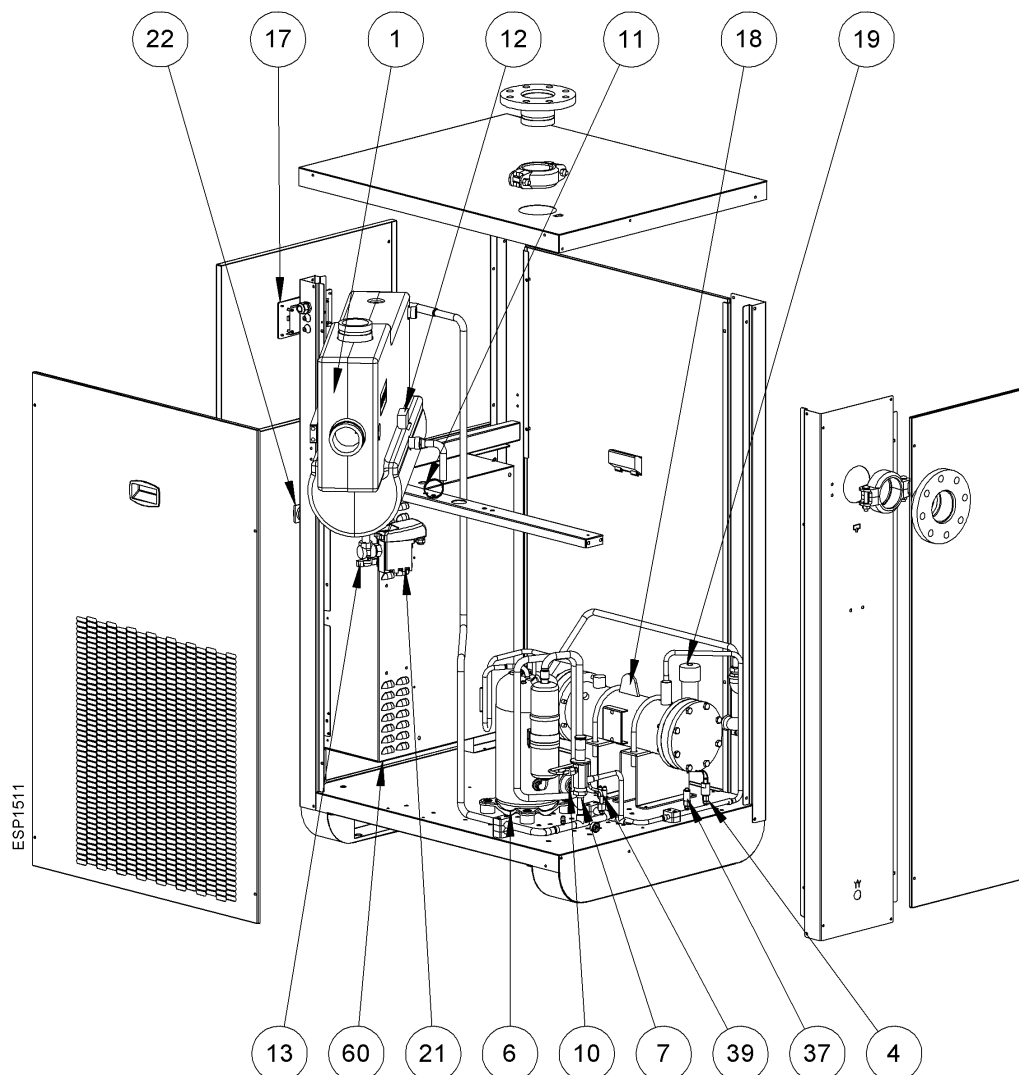

Pos. No.	Description / explanation
[1]	Heat exchanger
[4]	High pressure switch HPS
[6]	Refrigerant compressor
[7]	Hot gas by-pass valve
[10]	Refrigerant fluid filter
[11]	Capillary tube
[12]	Temperature probe BT1
[13]	Condensate drain service valve

Pos. No.	Description / explanation
[17]	User Interface
[18]	Water condenser
[19]	Water regulating valve
[21]	Condensate drain
[22]	ON-OFF switch
[37]	Pressure transducer BHP
[39]	Pressure transducer BLP
[60]	Electrical box

3.1.3 DRYPOINT® RA III 1490, 1900

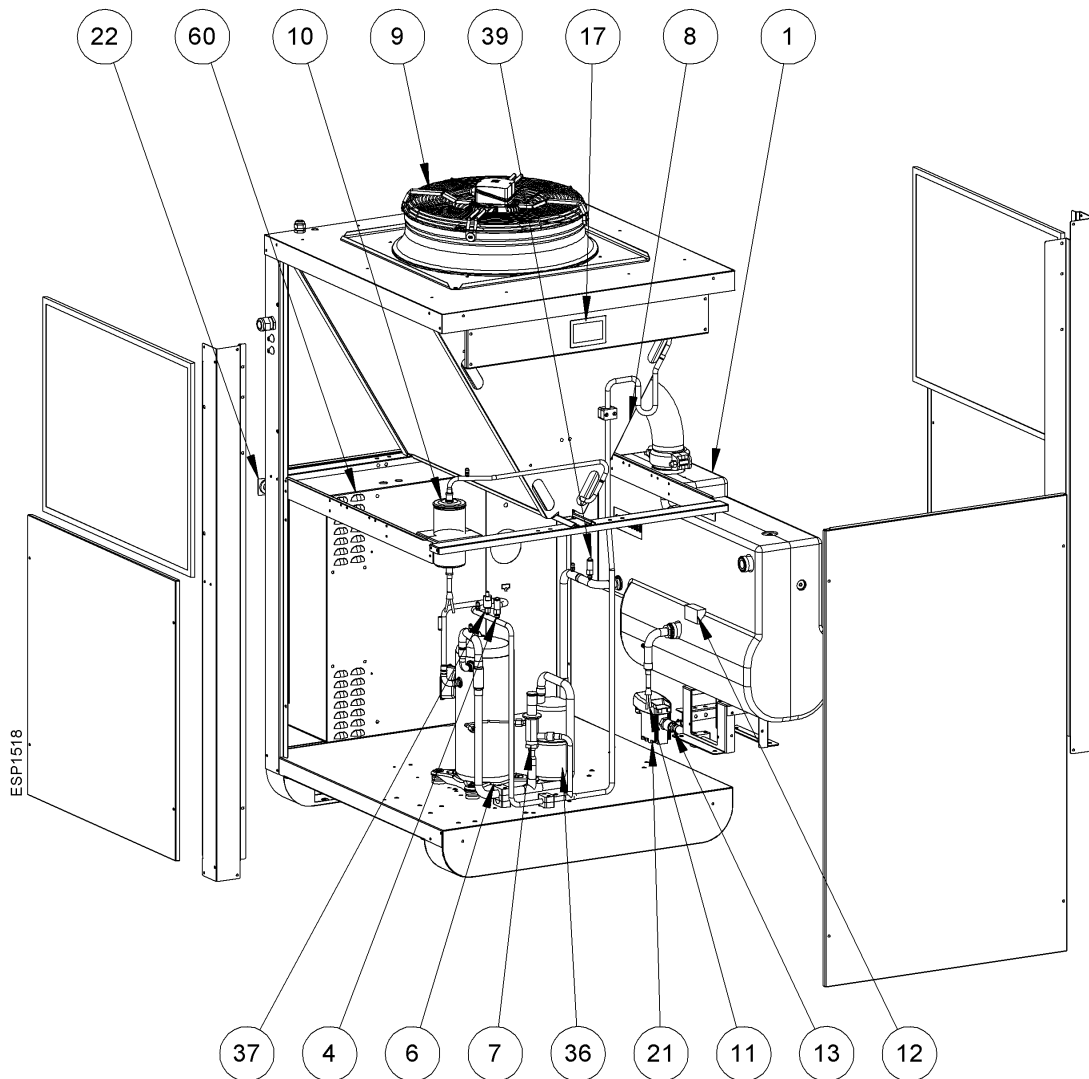

Pos. No.	Description / explanation
[1]	Heat exchanger
[4]	High pressure switch HPS
[6]	Refrigerant compressor
[7]	Hot gas by-pass valve
[8]	Condenser
[9]	Cooling fan
[10]	Refrigerant fluid filter
[11]	Capillary tube
[12]	Temperature probe BT1

Pos. No.	Description / explanation
[13]	Condensate drain service valve
[17]	User Interface
[21]	Condensate drain
[22]	ON-OFF switch
[36]	Liquid separator
[37]	Pressure transducer BHP
[39]	Pressure transducer BLP
[60]	Electrical box

3.1.4 DRYPOINT® RA III 1490, 1900 water-cooled

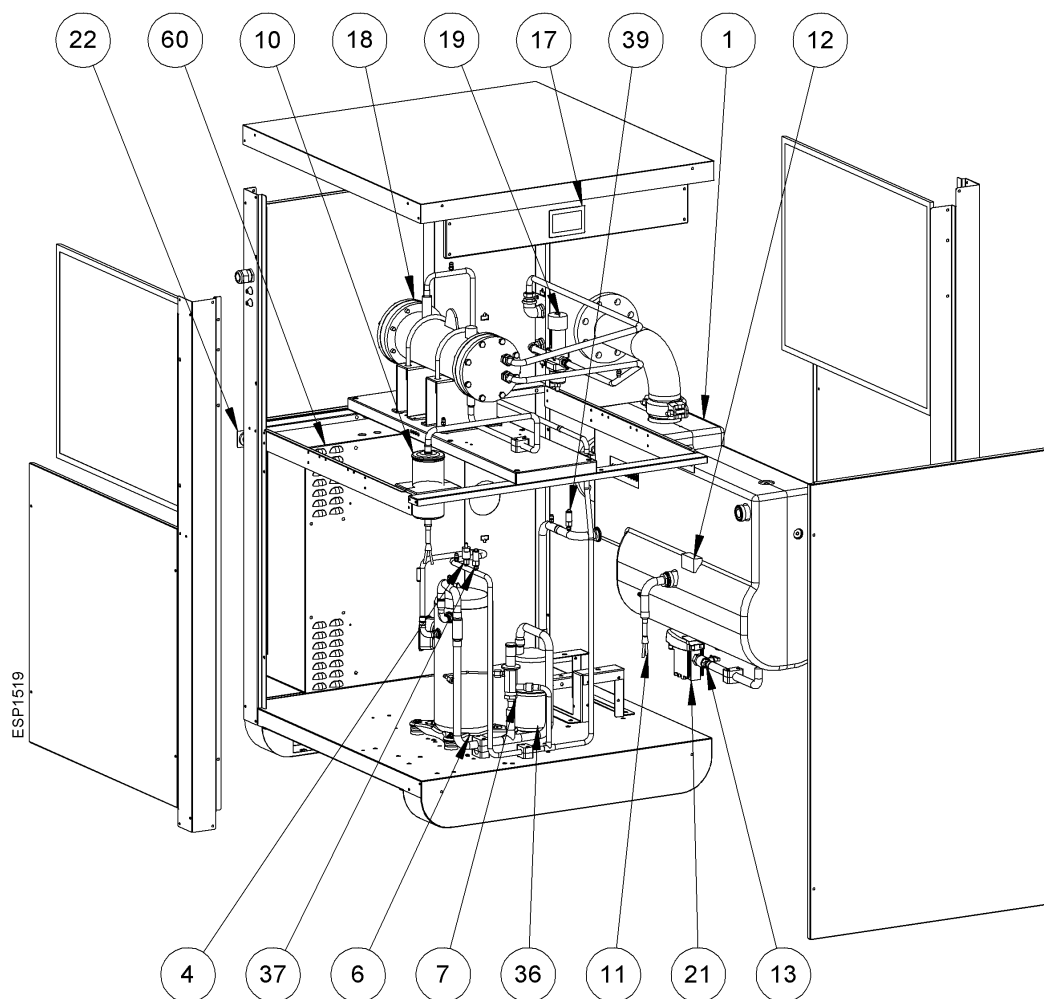

Pos. No.	Description / explanation
[1]	Heat exchanger
[4]	High pressure switch HPS
[6]	Refrigerant compressor
[7]	Hot gas by-pass valve
[10]	Refrigerant fluid filter
[11]	Capillary tube
[12]	Temperature probe BT1
[13]	Condensate drain service valve
[17]	User Interface

Pos. No.	Description / explanation
[18]	Water condenser
[19]	Water regulating valve
[21]	Condensate drain
[22]	ON-OFF switch
[36]	Liquid separator
[37]	Pressure transducer BHP
[39]	Pressure transducer BLP
[60]	Electrical box

3.1.5 DRYPOINT® RA III 2400, 3000

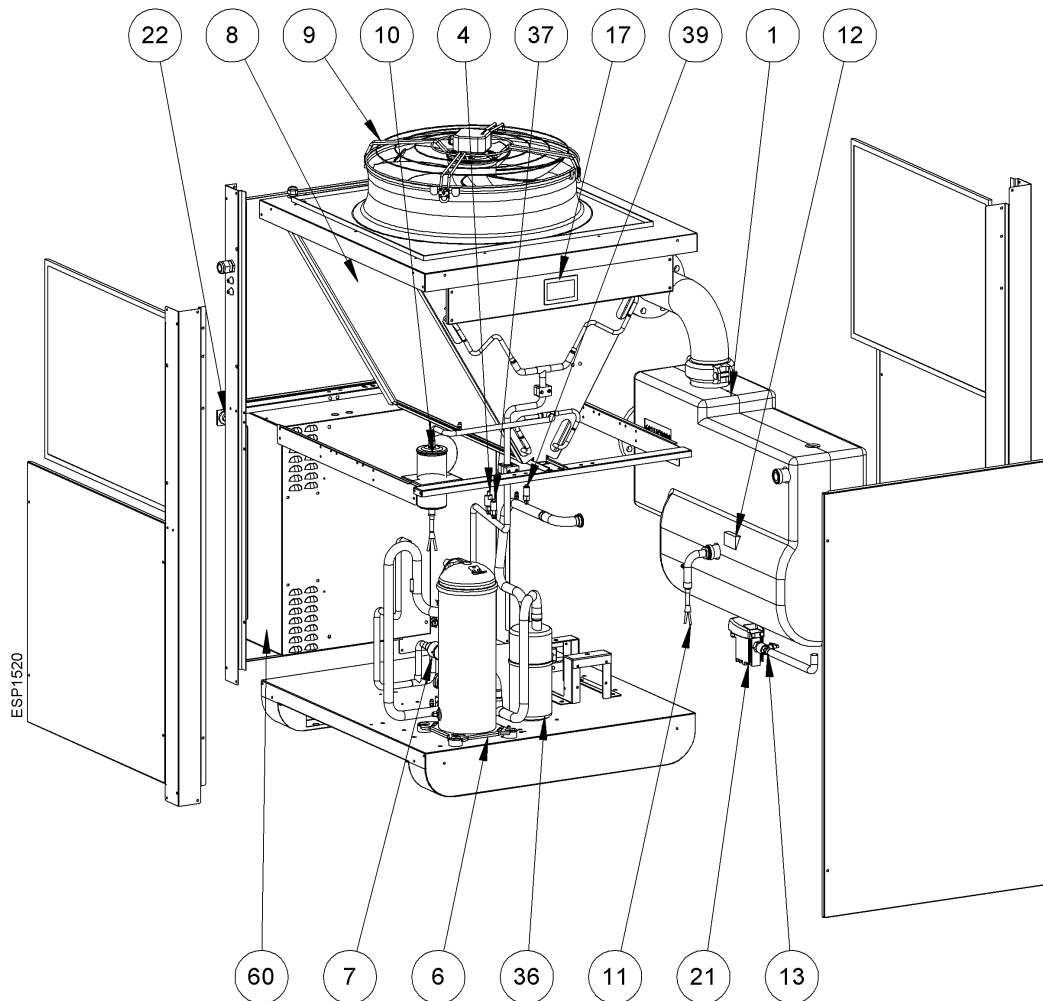

Pos. No.	Description / explanation
[1]	Heat exchanger
[4]	High pressure switch HPS
[6]	Refrigerant compressor
[7]	Hot gas by-pass valve
[8]	Condenser
[9]	Cooling fan
[10]	Refrigerant fluid filter
[11]	Capillary tube
[12]	Temperature probe BT1

Pos. No.	Description / explanation
[13]	Condensate drain service valve
[17]	User Interface
[21]	Condensate drain
[22]	ON-OFF switch
[36]	Liquid separator
[37]	Pressure transducer BHP
[39]	Pressure transducer BLP
[60]	Electrical box

3.1.6 DRYPOINT® RA III 2400, 3000 water-cooled

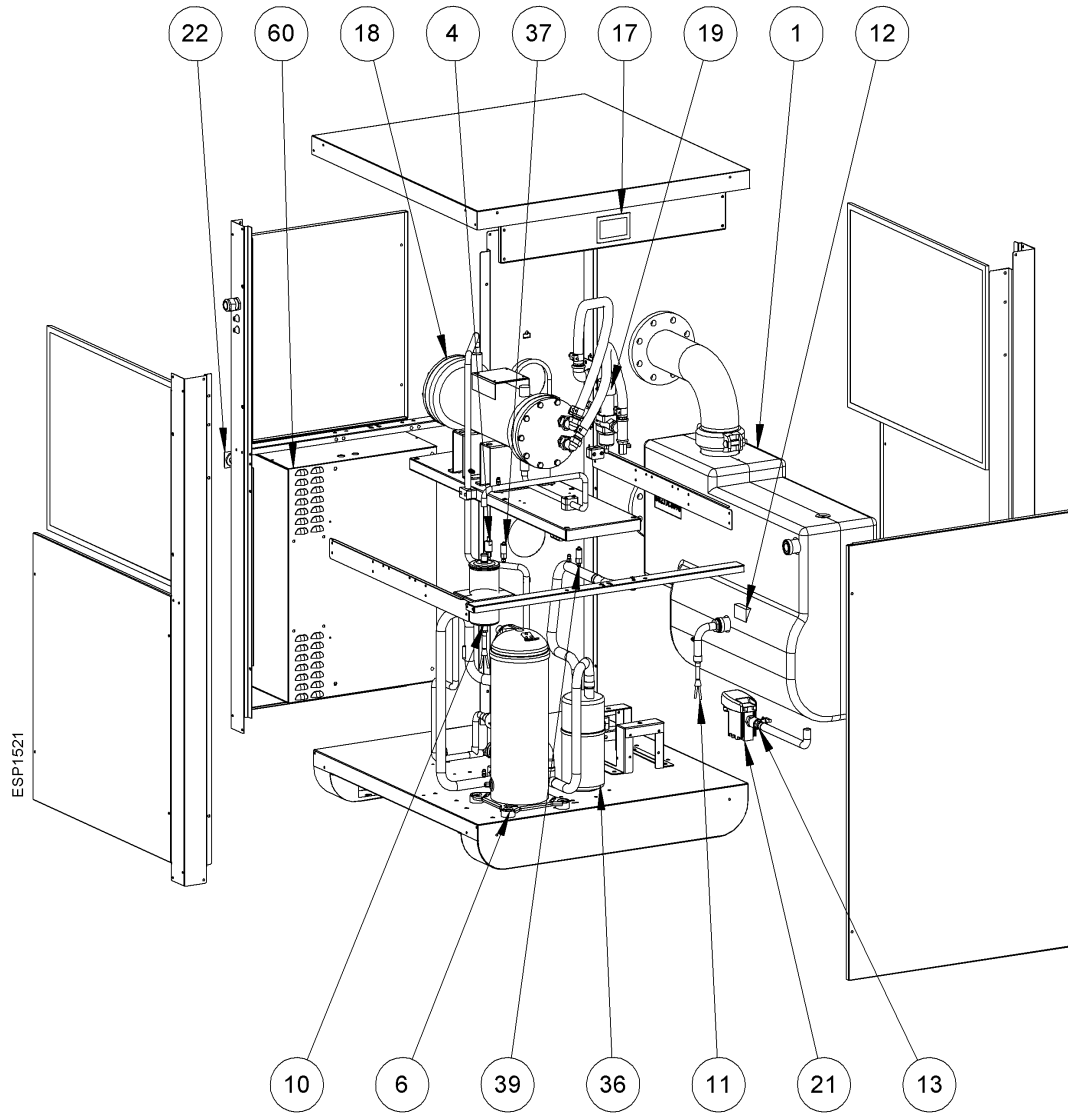

Pos. No.	Description / explanation
[1]	Heat exchanger
[4]	High pressure switch HPS
[6]	Refrigerant compressor
[7]	Hot gas by-pass valve
[10]	Refrigerant fluid filter
[11]	Capillary tube
[12]	Temperature probe BT1
[13]	Condensate drain service valve
[17]	User Interface

Pos. No.	Description / explanation
[18]	Water condenser
[19]	Water regulating valve
[21]	Condensate drain
[22]	ON-OFF switch
[36]	Liquid separator
[37]	Pressure transducer BHP
[39]	Pressure transducer BLP
[60]	Electrical box

3.2 Function description

3.2.1 Flow diagram, air-cooled models

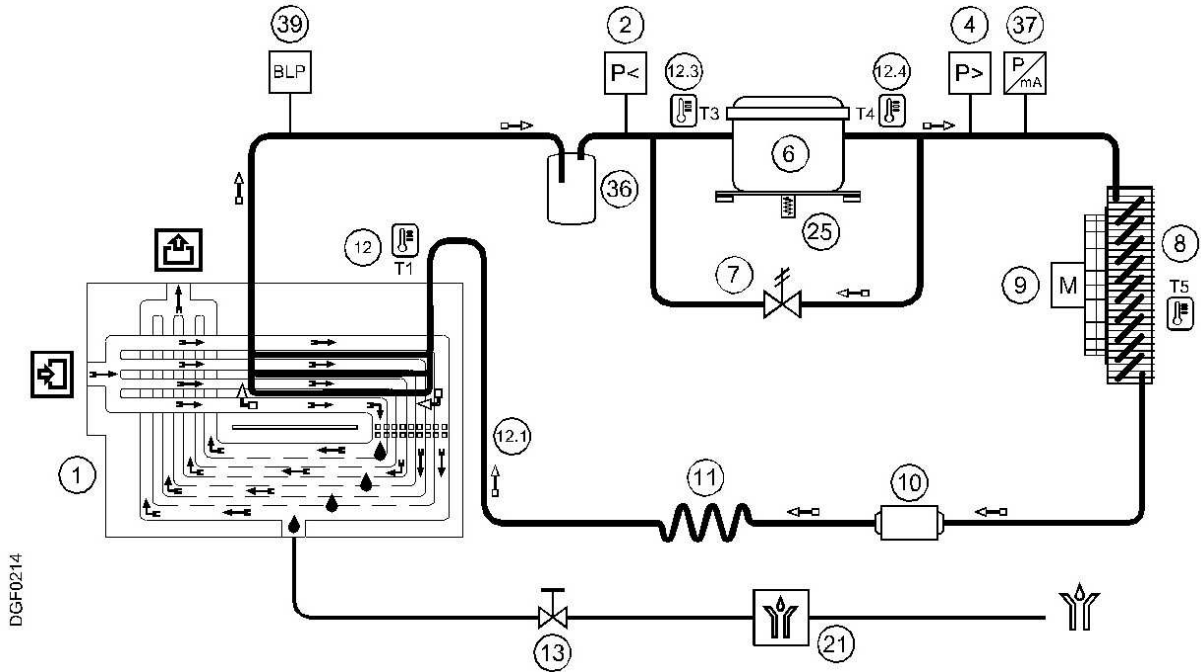

DGF0214

3.2.2 Flow diagram, water-cooled models

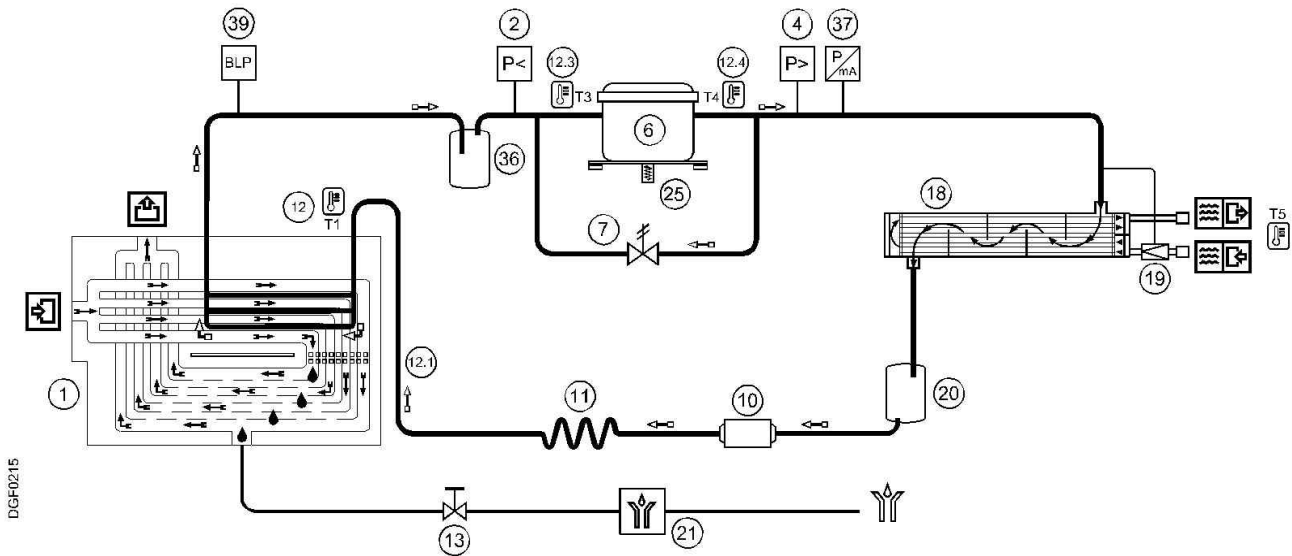

3.2.3 Compressed air flow

The hot, humid air enters the heat exchanger **[1]**, cools and reaches a temperature of approximately 2 °C. At this temperature, the humidity present in the air changes to a liquid state, precipitates to the bottom of the exchanger **[1]** and is expelled through the automatic condensate drain **[21]**. The cold, dry air is then channelled and heated again until it reaches a temperature at the outlet of the exchanger that is approximately 8 °C lower than the incoming air temperature.

3.2.4 Refrigerating cycle

The refrigerant compressor **[6]** compresses the refrigerant fluid and conveys it at high pressure towards the condenser **[8]** inside which the gas cools and becomes liquid at high pressure. The liquid refrigerant passes through the refrigerant fluid filter **[10]** and the capillary tube **[11]** where, due to the pressure drop, it reaches the preset temperature. The low pressure liquid refrigerant enters the heat exchanger **[1]** and the heat present in the environment is transferred to the liquid refrigerant causing its evaporation. The low pressure and low temperature refrigerant fluid then returns to the refrigerator compressor **[6]** where it is further compressed and the cycle repeats.

If there is low thermal load (compressed air at a flow rate lower than the dryer nominal flow rate), the excess refrigerant is automatically diverted from the delivery side by the refrigeration compressor **[6]** towards the suction side via the by-pass valve -hot gas pass **[7]**.

3.3 Type plate

3.3.1 DRYPOINT® RA III type plate

DPRA1080

Produktschlüssel:	4059830
Product key:	
Serienr. / Baujahr:	230025219 / 23
Serial n° / year of building:	
Nennvolumenstrom (ISO1217):	1080 m³/h
Nominal flow rate (ISO1217):	

Kältemittel / Refrigerant	V 2.4 liter
R 513A/ 1.35kg CO2 eq 0.852t GWP631	
PS HP21.8/LP20.9 bar	TS -5...120 °C

Druckluft / Compressed air	V 24.3 liter
PS 16 bar	TS 2...70 °C

Elektrisch / Electric

3/400V ± 10%/50Hz	☐ 16A
1.90kW/4.2A – FLA6.5A	IP42
Diagram 90BKGM13CEP00_R00	

Komplette Einheit / Complete unit

PED 2014/68/EU – Cat.II	Fluid Group 2
Umgebungstemperatur:	TS 1...50 °C
Ambient temperature:	

Hermetically sealed
Hermetisch geschlossen

Contains fluorinated greenhouse gases covered by
the Kyoto Protocol
Enthält vom Kyoto Protokoll erfasste fluorierte
Treibhausgase





BEKO

BEKO TECHNOLOGIES GMBH
 Im. Taubental 7, 41468 Neuss
 Germany
<http://www.beko-technologies.com>



2820

3.4 Scope of delivery

Illustration	Description / explanation
	<p>DRYPOINT® RA III</p>
	<p>Installation and operating manual</p>

4. Technical data

4.1 Operating parameters

INFORMATION	Nominal conditions
	The nominal condition refers to an ambient temperature of +25 °C (+77.0 °F) with inlet air at 7 bar(g) (101.5 psi(g)) and +35 °C (+95.0 °F).

INFORMATION	Refrigerant quantity
	Refrigerant quantity stated below is the design value. The type plate records the quantity of refrigerant used in each device.

Operating parameters		
Parameter	Unit	Value
Pressure dew point at nominal conditions	°C (°F)	+3 (+37.4)
Nominal ambient temperature		+25 (+77.0)
Min. ... max. ambient temperature		+1 ... +50 (+33.8 ... +122.0)
Nominal inlet air temperature		+35 (+95.0)
Max. inlet air temperature		+70 (+158.0)
Nominal inlet air pressure	bar(g) (psi(g))	7 (101.5)
Max. inlet air pressure		16 (232.1)
Refrigerant fluid	Type	R513A
	GWP	631
Max. noise level at 1 m	dbA	< 75

4.1.1 DRYPOINT® RA III 1080 ... 1300



Parameter	Unit	DRYPOINT® RA III			
		1080	1080 WC	1300	1300 WC
Air flow rate at nominal conditions	m³/h	1080		1260	
	l/min	18000		21000	
	scfm	636		742	
Air pressure drop	bar (psi)	0.07 (1.02)		0.09 (1.31)	
Cooling air fan flow	m³/h (cfm)	3500 (2060.0)	-	3500 (2060.0)	-
Cooling water flow @ 30 °C (86 °F)		-	0.97 (0.571)	-	0.97 (0.571)
Heat rejection	kW (btu/h)	11.00 (37534)		11.00 (37534)	
Refrigerant quantity	kg (oz)	1.35 (47.½)	2.00 (71)	1.60 (56.½)	2.40 (85)
Power supply	V/ph/f	400/3/50			
Nominal electric consumption	kW	1.90	1.70	1.90	1.70
	A	3.2	2.8	3.2	2.8
Full load amperage	A	6.2	5.5	6.2	5.5

4.1.2 DRYPOINT® RA III 1490 ... 1900



Parameter	Unit	DRYPOINT® RA III			
		1490	1490 WC	1900	1900 WC
Air flow rate at nominal conditions	m³/h	1500		1900	
	l/min	25000		31667	
	scfm	883		1119	
Air pressure drop	bar	0.06		0.09	
	(psi)	(0.87)		(1.31)	
Cooling air fan flow	m³/h (cfm)	7000 (4120.0)	-	7000 (4120.0)	-
Cooling water flow @ 30°C (86 °F)		-	1.13 (0.665)	-	1.46 (0.859)
Heat rejection	kW	13.00		17.00	
	(btu/h)	(44358)		(58006)	
Refrigerant quantity	Kg	2.00	3.00	2.00	3.00
	(oz)	(71)	(106)	(71)	(106)
Power supply	V/ph/f	400/3/50			
Nominal electric consumption	kW	2.20	2.00	2.90	2.60
	A	4.0	3.6	5.5	4.9
Full load amperage	A	8.9	7.1	10.7	8.9

4.1.3 DRYPOINT® RA III 2400 ... 3000



Parameter	Unit	DRYPOINT® RA III			
		2400	2400 WC	3000	3000 WC
Air flow rate at nominal conditions	m³/h	2400		3000	
	l/min	40000		50000	
	scfm	1413		1767	
Air pressure drop	bar (psi)	0.09 (1.31)		0.13 (1.89)	
Cooling air fan flow	m³/h (cfm)	12000 (7062.9)	-	12000 (7062.9)	-
Cooling water flow @ 30°C (86 °F)		-	1.94 (1.142)	-	2.51 (1.477)
Heat rejection	kW (btu/h)	22.00 (75067)		28.00 (95540)	
Refrigerant quantity	kg (oz)	2.70 (95)	4.10 (145)	2.70 (95)	4.10 (145)
Power supply	V/ph/f	400/3/50			
Nominal electric consumption	kW	3.90	3.50	6.10	4.90
	A	8.8	8.2	16.0	15.0
Full load amperage	A	14.8	12.8	21.2	19.2

4.1.4 DRYPOINT® RA III 1080 ... 1300 @60Hz



Parameter	Unit	DRYPOINT® RA III	
		1080	1300
Air flow rate at nominal conditions	m³/h	1080	1260
	l/min	18000	21000
	scfm	636	742
Air pressure drop	bar	0.07	0.09
	(psi)	(1.02)	(1.31)
Cooling air fan flow	m³/h (cfm)	5000 (2942.9)	
Heat rejection	kW	13.00	
	(btu/h)	(44358)	
Refrigerant quantity	kg	1.35	1.60
	(oz)	(47.½)	(56.½)
Power supply	V/ph/f	400/3/60	
Nominal electric consumption	kW	2.40	
	A	3.8	
Full load amperage	A	6.2	

4.1.5 DRYPOINT® RA III 1490 ... 3000 @60Hz



Parameter	Unit	DRYPOINT® RA III			
		1490	1900	2400	3000
Air flow rate at nominal conditions	m ³ /h	1500	1900	2400	3000
	l/min	25000	31667	40000	50000
	scfm	883	1119	1413	1767
Air pressure drop	bar	0.06	0.09	0.09	0.13
	(psi)	(0.87)	(1.31)	(1.31)	(1.89)
Cooling air fan flow	m ³ /h	8500		11800	
	(cfm)	(5002.9)		(6945.2)	
Heat rejection	kW	16.00	20.00	27.00	34.00
	(btu/h)	(54594)	(68243)	(92128)	(116013)
Refrigerant quantity	kg	2.00		2.70	
	(oz)	(71)		(95)	
Power supply	V/ph/f	400/3/60			
Nominal electric consumption	kW	3.70	4.60	5.50	6.90
	A	6.0	7.3	10.1	15.7
Full load amperage	A	9.3	11.1	14.8	21.2

4.2 Correction factors

Corrections factors (CF)												
Parameter	Unit	Value										
Ambient Temp.	°C	≤ +25	+30	+35	+40	+45	+50					
	(°F)	(+77.0)	(+86.0)	(+95.0)	(+104.0)	(+113.0)	(+122.0)					
CF		1.00	0.96	0.91	0.85	0.76	0.64					
Inlet air Temp.	°C	≤ +25	+30	+35	+40	+45	+50	+55	+60	+65	+70	
	(°F)	(+77.0)	(+86.0)	(+95.0)	(+104.0)	(+113.0)	(+122.0)	(+131.0)	(+140.0)	(+149.0)	(+158.0)	
CF		1.48	1.23	1.00	0.82	0.67	0.54	0.46	0.41	0.38	0.36	
Inlet air pressure	bar(g)	4	5	6	7	8	10	12	14	15	16	
	(psi(g))	(58.0)	(72.5)	(87.0)	(101.5)	(116.0)	(145.0)	(174.0)	(203.1)	(217.6)	(232.1)	
CF		0.77	0.86	0.93	1.00	1.05	1.14	1.21	1.27	1.30	1.33	
Dew point	°C	+3	+5	+7	+10							
	(°F)	(+37.4)	(+41.0)	(+44.6)	(+50.0)							
CF		1.00	1.09	1.19	1.37							

4.3 Cooling water parameters, water-cooled models

Parameter	Unit	Value
Min. ... max. water temperature	°C (°F)	+15 ... +30 (+59.0 ... +86.0)
Min. ... max. water pressure	bar(g) (psi(g))	3 ... 10 (43.5 ... 145.0)
Required head pressure	bar (psi)	> 3 (> 43.5)
PH value	-	7.5 ... 9.0
Total hardness	°dH	6.0 ... 15
Conductivity	µS/cm	10 ... 1000
Sulphates (SO ₄ ²⁻)	mg/l or ppm	< 100
Hydrogen carbonate / Sulphates (HCO ₃ / SO ₄ ²⁻)		> 1
Ammonia (NH ₃)		< 0.5
Manganous ion (Mn ²⁺)		< 0.05
Chlorides (Cl ⁻)		< 50
Free chlorine		< 0.5
Oxygen content		< 0.1
Carbon dioxide (CO ₂)		< 50
Hydrogen sulphide (H ₂ S)		< 0.05
Phosphate (PO ₄ ³⁻)		< 2
Ferric ion (Fe ³⁺)		< 0.5

4.4 Storage parameters

Parameter	Unit	DRYPOINT® RA III					
		1080	1080 WC	1300	1300 WC	1490	1490 WC
Min. ... max. temperature	°C (°F)	+1 ... +50 (+33.8 ... +122.0)					
Relative humidity	%	Max 80% without condensation					
Weight	kg (lbs)	231 (509)	241 (531)	238 (525)	248 (547)	261 (575)	276 (608)

Parameter	Unit	DRYPOINT® RA III					
		1900	1900 WC	2400	2400 WC	3000	3000 WC
Min. ... max. temperature	°C (°F)	+1 ... +50 (+33.8 ... +122.0)					
Relative humidity	%	Max 80% without condensation					
Weight	kg (lbs)	263 (580)	278 (613)	337 (743)	352 (776)	338 (745)	353 (778)

4.5 Materials

Component	Material
Housing and supports	Structural steel, epoxy paint
Refrigerant compressor	Steel, copper, aluminium, oil
Heat exchanger	Aluminium
Condenser	Aluminium, copper, structural steel
Pipes	Copper
Fan	Aluminium, copper, steel
Valves	Brass, steel
BEKOMAT ® condensate drain	Aluminium, plastic mix and electronics
Insulating material	Synthetic rubber, polystyrene, polyurethane
Electronic Control Unit	Plastic mix and electronics
Electric cables, electric parts	Copper, brass, PVC, plastic mix

4.6 Dimensions

4.6.1 DRYPOINT® RA III 1080 ... 1300

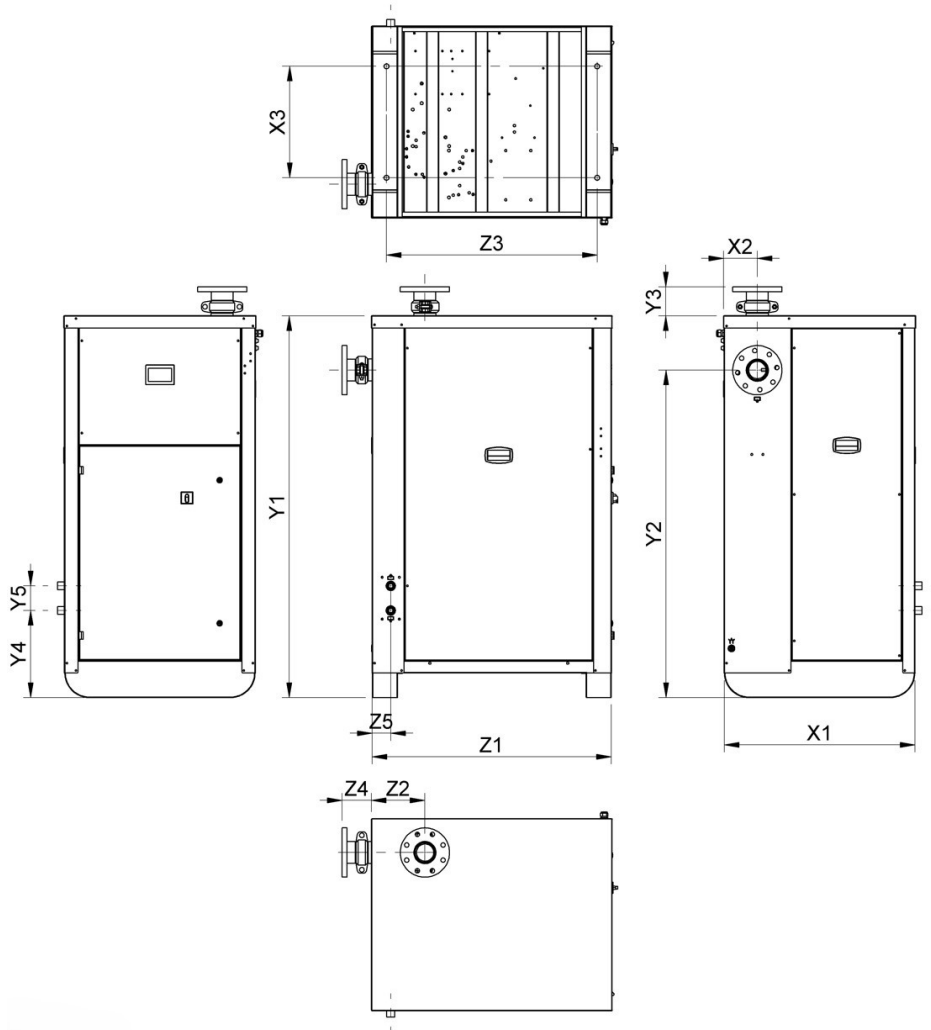

Pos. No.	Unit	DRYPOINT® RA III	
		1080	1300
[X1]	mm (in)	775 (30.51)	
[X2]		138 (5.43)	
[X3]		453 (17.83)	
[Y1]		1550 (61.02)	
[Y2]		1331 (52.40)	
[Y3]		117 (4.61)	
[Y4]		354 (13.94)	
[Y5]		100 (3.94)	
[Z1]		975 (38.39)	
[Z2]		217 (8.54)	
[Z3]		856 (33.70)	
[Z4]		120 (4.72)	
[Z5]		75 (2.95)	

4.6.2 DRYPOINT® RA III 1490 ... 3000

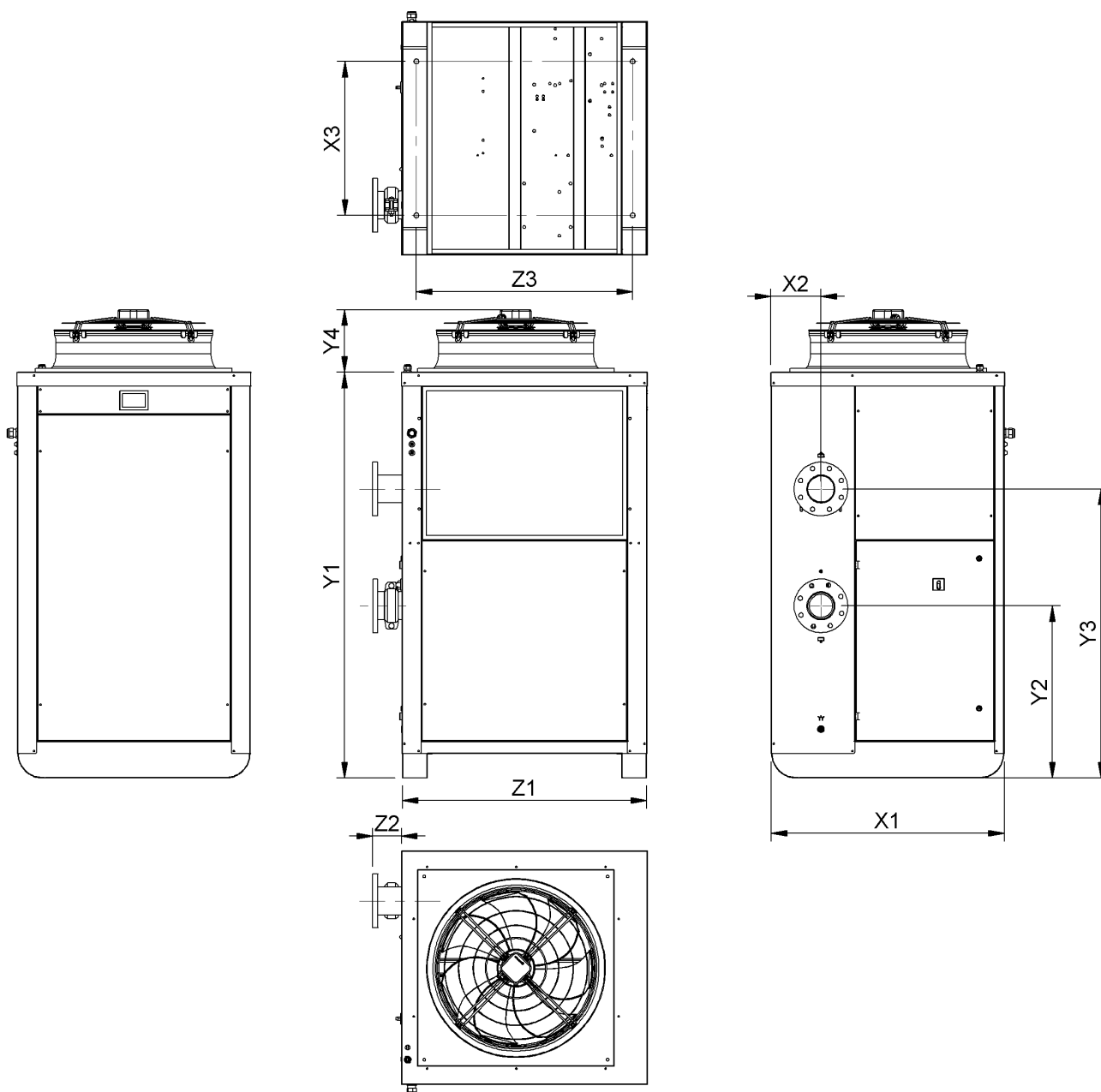

Pos. No.	Unit	DRYPOINT® RA III			
		1490	1900	2400	3000
[X1]	mm (in)	957 (37.68)			
[X2]		170 (6.69)		205 (8.07)	
[X3]		630 (24.80)			
[Y1]		1661 (65.39)			
[Y2]		644 (25.35)		705 (27.76)	
[Y3]		1057 (41.61)		1183 (46.57)	
[Y4]		255 (10.04)			
[Z1]		1006 (39.61)			
[Z2]		114 (4.49)		118 (4.65)	
[Z3]		885 (3.35)			

4.6.3 DRYPOINT® RA III 1490 ... 3000 water-cooled

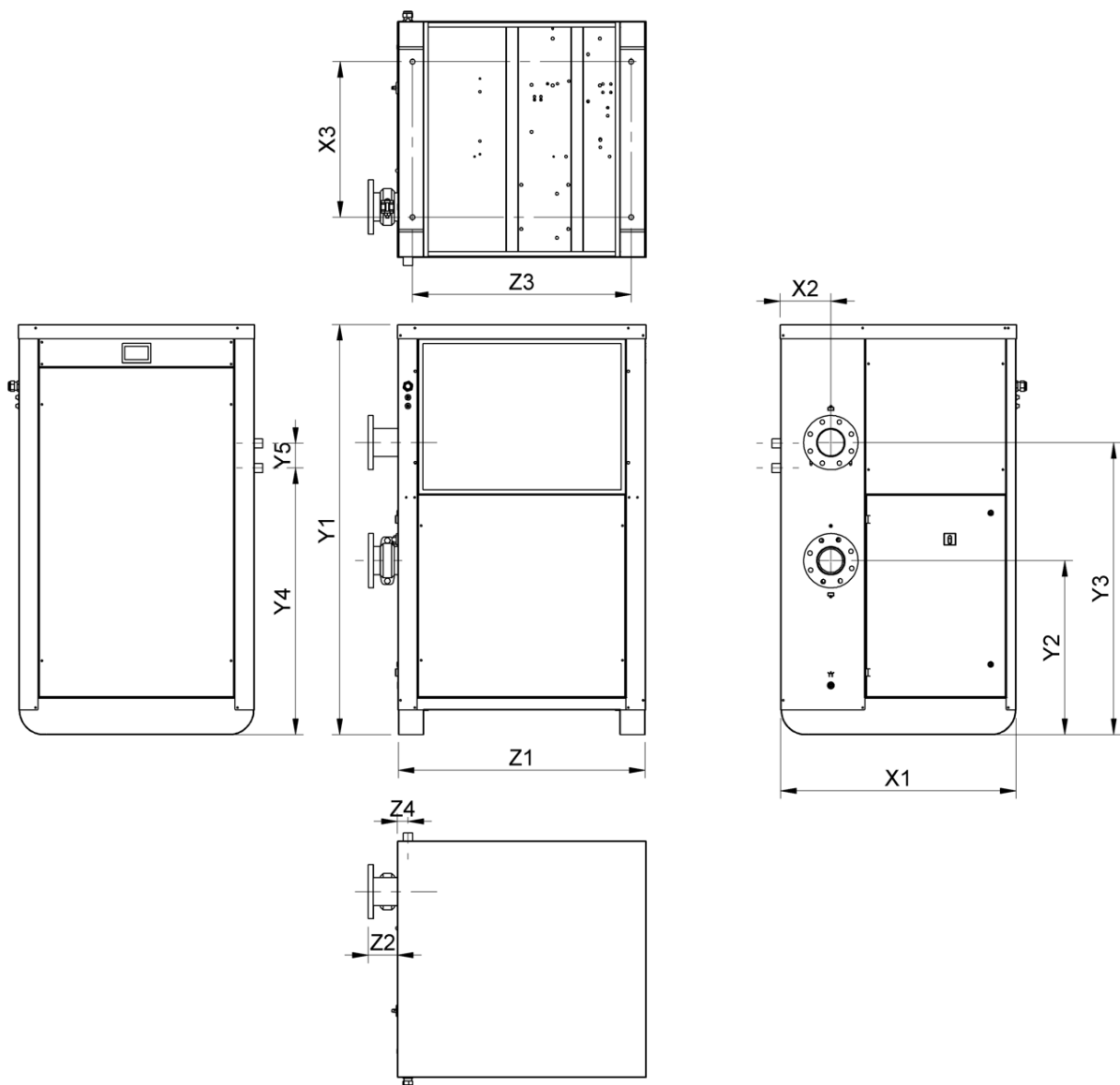

Pos. No.	Unit	DRYPOINT® RA III			
		1490 WC	1900 WC	2400 WC	3000 WC
[X1]	mm (in)	957 (37.68)			
[X2]		170 (6.69)		205 (8.07)	
[X3]		630 (24.80)			
[Y1]		1661 (65.39)			
[Y2]		644 (25.35)		705 (27.76)	
[Y3]		1057 (41.61)		1183 (46.57)	
[Y4]		1080 (42.52)			
[Y5]		100 (3.94)			
[Z1]		1006 (39.61)			
[Z2]		114 (4.49)		118 (4.65)	
[Z3]		885 (3.35)			
[Z4]		42 (1.65)			

4.7 Connections

4.7.1 DRYPOINT® RA III 1080 ... 1300

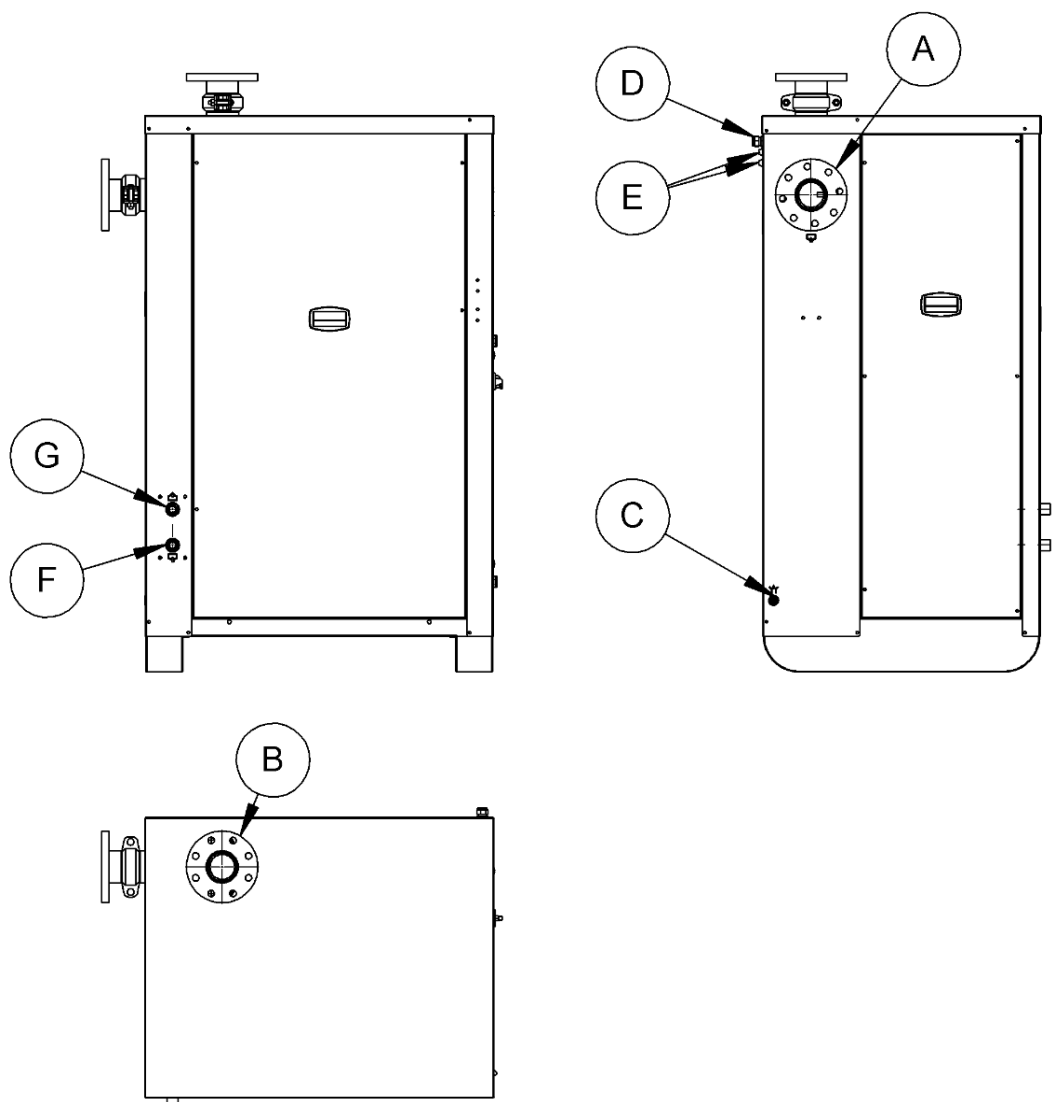

DRYPOINT® RA III	Pos. No.	Connection	Description / explanation
1080 ... 1300	[A]	DN 80	Flanged connection, connection for compressed air inlet
	[B]	DN 80	Flanged connection, connection for compressed air outlet
	[C]	8 mm (0.31 in)	Rubber hose, connection for condensate outlet
	[D]	M 20	Cable gland, connection for external power supply
	[E]	PG 11	Rubber grommets, connection for auxiliary wiring
	[F]	G ¾"	Sleeve connection, connection for cooling water inlet, water-cooled models
	[G]	G ¾"	Sleeve connection, connection for cooling water outlet, water-cooled models

4.7.2 DRYPOINT® RA III 1490 ... 3000

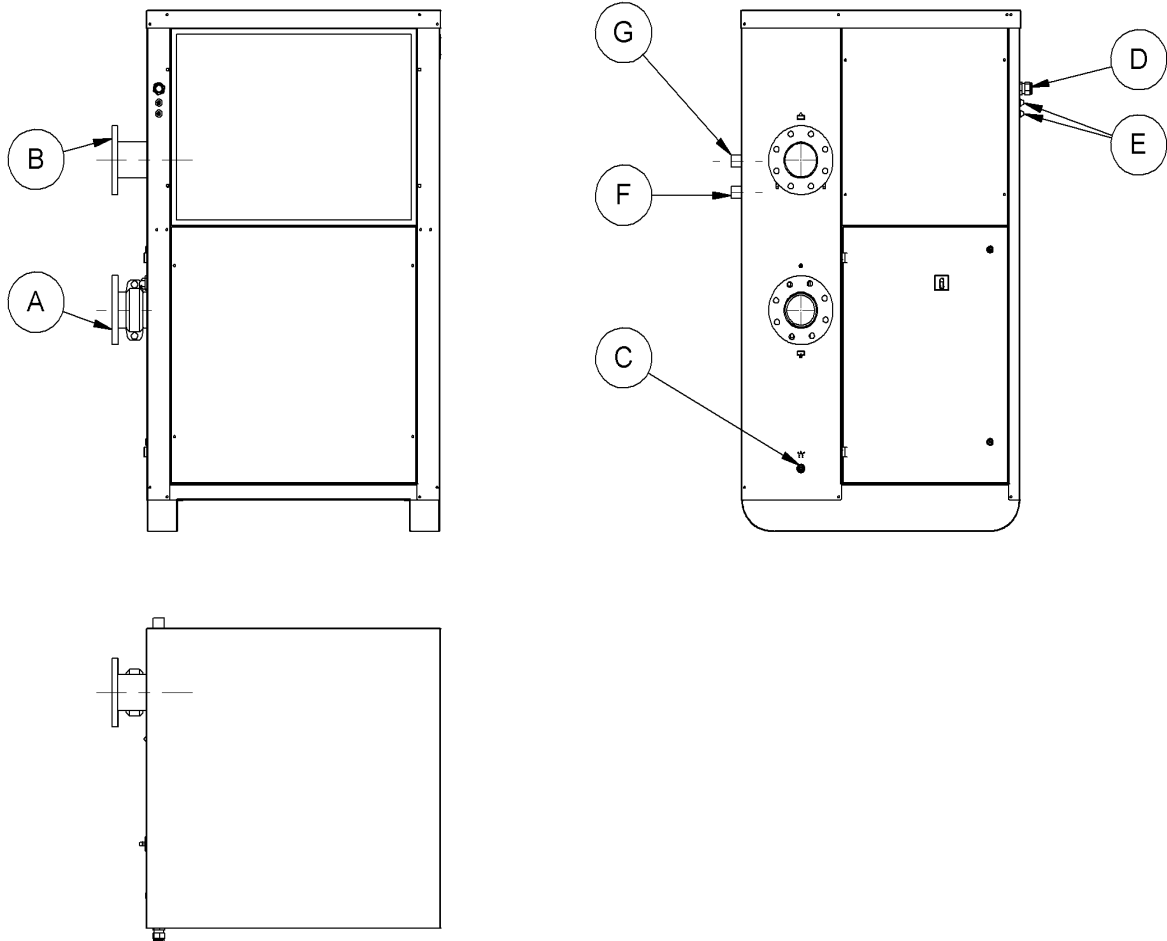

DRYPOINT® RA III	Pos. No.	Connection	Description / explanation
1490 ... 1900	[A]	DN 80	Flanged connection, connection for compressed air inlet
	[B]	DN 80	Flanged connection, connection for compressed air outlet
2400 ... 3000	[A]	DN 100	Flanged connection, connection for compressed air inlet
	[B]	DN 100	Flanged connection, connection for compressed air outlet
1490 ... 3000	[C]	8 mm (0.31 in)	Rubber hose, connection for condensate outlet
	[D]	M 32	Cable gland, connection for external power supply
	[E]	PG 11	Rubber grommets, connection for auxiliary wiring
	[F]	G 1"	Sleeve connection, connection for cooling water inlet, water-cooled models
	[G]	G 1"	Sleeve connection, connection for cooling water outlet, water-cooled models

4.8 Assembly conditions

Observe the following conditions when setting up and selecting the installation location:

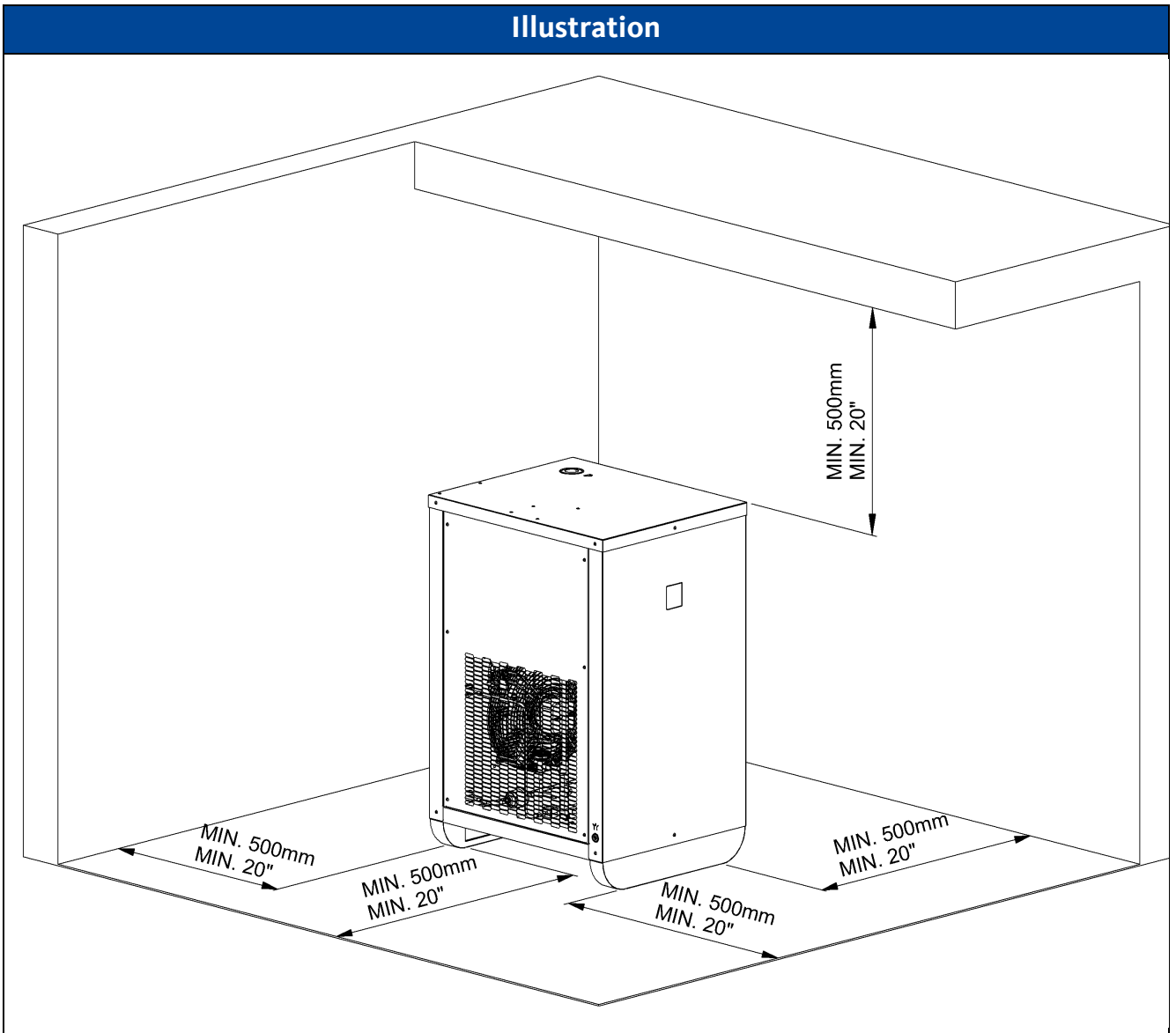

- The location must be clean and dry, protected from direct sunlight, rain, frost, sources of heat and fire. Unlimited exchange of air and sufficient ventilation must be guaranteed, refer to section "4.8.1 Minimum distance from adjacent structure" on page 45.
- The location must have sufficient space for product assembly and maintenance.
- The set-up area must be level, smooth and suitable to bear the product's weight.
- Sealed set-up area or spill protection basin must be available. If there is any damage, untreated condensate or oil must not get into the sewer system or soil.
- A customer-side compressed air supply line is available.
- A customer-side condensate collection line is available.
- A customer-side 3ph+E power supply line is available.
- A customer-side cooling water line is available for water-cooled models. Cooling water meets the requirements specified in section "4.3 Cooling water parameters, water-cooled models" on page 36.

4.8.1 Minimum distance from adjacent structures





5. Transport and storage

5.1 Warning notices

WARNING	Insufficient qualification
	<p>If personnel carrying out work on the product and accessories are not properly qualified, this may result in accidents, personal injury and damage to property and impair operations.</p>
	<ul style="list-style-type: none"> • Work on the product and accessories must be carried out exclusively by skilled technical personnel specialising in transport and storage.
CAUTION	Incorrect transport or storage
	<p>Incorrect transport or storage may result in personal injury or damage to property.</p>
	<ul style="list-style-type: none"> • Use personal protective equipment while working with packaging material. • Handle the packaging, product and accessories with care. • Pack impact-proof parts using suitable material. • Transport and handle the packaging under the markings (note lifting gear attachment points, the centre of gravity and alignment e.g. keep vertical, do not throw, etc.). • Use means of transport and lifting equipment that is working properly. • Comply with permissible transport and storage parameters. • Store the product and accessories outside areas exposed to direct sunlight and heat sources.
NOTE	Handling packaging material
	<p>Incorrect disposal of packaging material can cause environmental damage.</p>
	<ul style="list-style-type: none"> • Dispose of the packaging material under the applicable legal requirements and provisions of the country and place of use.

5.2 Transport

NOTE	Incorrect handling of the product
	Product damage might occur if it is not kept upright during transport. Heavy blows will cause irreparable damage.
	<ul style="list-style-type: none"> • Transport the product with care, in an upright position.

Transporting	
Illustration	Description / explanation
	<ul style="list-style-type: none"> • Transport the product and accessories in their original and undamaged packaging. • Use a suitable trolley or a forklift to move the packaged product and accessories.

5.3 Storage



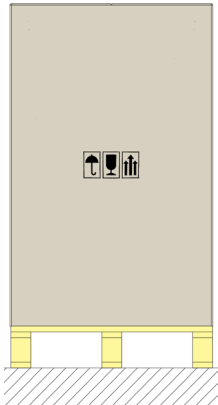

NOTE	Incorrect storage of the product
	Product damage might occur if it is not kept upright during transport. <ul style="list-style-type: none"> • Store the product in an upright position.

NOTE	Long term storage
	After a long storage period the device components and functioning must be checked by the manufacturer. <ul style="list-style-type: none"> • Contact the manufacturer if storage period exceeds 12 months.

Storage	
Illustration	Description / explanation
	<ul style="list-style-type: none"> • Store the product and accessories in their original and undamaged packaging. • Comply with the storage conditions in section "4.4 Storage parameters" on page 37. • The storage location must be dry, frost-free and lockable. • Protect from weather, direct sunlight, and heat sources. • Prevent the product from falling over and vibrations.

6. Assembly

6.1 Warning notices

DANGER	Incorrect spare parts, accessories or materials
	Using the incorrect spare parts, accessories or materials, and auxiliary and operating materials, may result in death or serious injury. Malfunctions, device failure and material damage can occur.
	<ul style="list-style-type: none"> • Use undamaged original parts, auxiliary and operating materials which are specified by the manufacturer to complete work. • Use the materials approved for the related application and tools that are working properly. • Use pipes that are free from dirt, damage and corrosion.
DANGER	Pressurised system
	There is a danger of death or serious personal injury resulting from contact with fast or suddenly escaping fluids or bursting system parts.
	<ul style="list-style-type: none"> • Before starting work, depressurise the system and secure it against unintentional pressurisation. • Set up a safety area around the working area during assembly, installation, maintenance and repair work. • Assemble pipes and hoses free from mechanical stress.
WARNING	Insufficient qualification
	If personnel carrying out work on the product and accessories are not properly qualified, this may result in accidents, personal injury and damage to property and impair operations.
	<ul style="list-style-type: none"> • Work on the product and accessories must be carried out exclusively by skilled technical personnel specialising in pressure equipment and systems.
WARNING	Incorrect assembly
	Incorrect assembly of the product and accessories can lead to personal injury and damage to property and impair operations.
	<ul style="list-style-type: none"> • Assemble the product, parts, accessories and materials so they are free from mechanical stress. • Fix hoses so they do not dangle.

6.2 Assembly

Assembly must be carried out while wearing the following protective equipment and after the preparatory tasks have been completed.

Prerequisites		
Tools	Material	Protective equipment
<ul style="list-style-type: none"> No tool necessary 	<ul style="list-style-type: none"> No material necessary 	

Preparatory tasks	
1.	Select and set up the place of installation under the specifications in section "4.8 Assembly conditions" on page 44.
2.	The compressed air supply line, condensate collection line, cooling water line provided by the customer must be pressureless and secured against unintentional pressure build up.
3.	Have the necessary tools and materials ready.
4.	Prepare the required connection materials suitable for the pressure and temperature range.
5.	Check the product for damage, and use undamaged products.
6.	Section "4.7 Connections" on page 42 must be read and applied.



Assembly	
1.	Align the product so the User Interface is visible and connection elements are accessible.
2.	Fix the product to the floor, if necessary.
3.	Compressed air: connect the flanged connection to the compressed air line.
4.	Cooling water, water-cooled models: connect the threaded connection to the cooling water line.
5.	Condensate drain: connect the condensate drain hose to the drain collection line.
6.	Install collision protection, if necessary.

7. Electrical installation

7.1 Warning notices

DANGER	Incorrect spare parts, accessories or materials
	<p>Using the incorrect spare parts, accessories or materials, and auxiliary and operating materials, may result in death or serious injury. Malfunctions, device failure and material damage can occur.</p> <ul style="list-style-type: none"> • Use undamaged original parts, auxiliary and operating materials which are specified by the manufacturer to complete work. • Use the materials approved for the related application and tools that are working properly. • Use electrical components and materials that comply with local applicable specifications and regulations for electrical safety.

DANGER	Electric voltage
	<p>There is a danger of death or serious injuries if electrified components are touched. Malfunction, device failure and material damage can occur.</p> <ul style="list-style-type: none"> • Carry out installation, maintenance and repair work on the product and accessories when they have been disconnected and secured against being accidentally switched on. • Set up a safety area around the working area during assembly, installation, maintenance and repair work. • Comply with local applicable regulations and requirements during installation. • Provide a circuit breaker in the power supply within easy reach of the product. The circuit breaker disconnects current-carrying conductors. • Connect the protective conductor (earth connection) under regulations.

WARNING	Insufficient qualification
	If personnel carrying out work on the product and accessories are not properly qualified, this may result in accidents, personal injury and damage to property and impair operations.
	<ul style="list-style-type: none"> • Work on the product and accessories must be carried out exclusively by skilled technical personnel specialising in electrical engineering.
WARNING	Incorrect electrical installation
	Improper electrical installation of the product and accessories can lead to personal injury and damage to property and impair operations.
	<ul style="list-style-type: none"> • Check the plug-type connections for a correct fit. • Avoid tripping risks by routing cables and hoses properly. • Avoid mechanical strain on the cables.
WARNING	Entry of moisture or foreign bodies
	Removing components or opening the product may allow water or foreign bodies to enter the product. Entry of water or foreign bodies can lead to accidents, personal injury, damage to property and impair operation.
	<ul style="list-style-type: none"> • Protect the product against water splashes or moisture. • Open the product or remove components in a dry place. • Do not insert any foreign bodies into product openings. • Keep contact surfaces and openings free from dirt and moisture.

7.2 Connections

Electrical installation must be carried out while wearing protective equipment and after the preparatory tasks have been completed.

Prerequisites		
Tools	Material	Protective equipment
<ul style="list-style-type: none"> No tool necessary 	<ul style="list-style-type: none"> No material necessary 	

Preparatory tasks	
1.	A 3ph+E protective contact socket or a terminal box must be installed within reach of the installation location.
2.	The fuse or circuit breaker for the protective contact socket or terminal box should be properly sized according to the fuse current mentioned on the data plate. The tripping characteristic must be DELAYED TRIPPING (aM) for fuse or D-CHARACTERISTIC for circuit breaker.
3.	Product assembly must be complete.
4.	ON-OFF switch of the product must be in the OFF position.
5.	Have the necessary tools and materials ready.
6.	A 3ph+E power cable correctly dimensioned for the product power consumption and a suitable length must be ready and available.
7.	Section "4.7 Connections" on page 42 must be read and applied.

7.2.1 External power supply

NOTE	Wrong phase sequence
	<p>An incorrect phase sequence of L1, L2, L3 will prevent the product from starting.</p> <ul style="list-style-type: none"> Phases L1, L2, L3 must be connected to the device with correct phase sequence.

Connections	
1.	Guide the power cable through the arranged cable gland on the product.
2.	Product side: Connect the cable to terminals L1, L2, L3, EARTH.
3.	Plant side: connect the cable to the protective contact socket / terminal box.
4.	Ensure the power cable is free from mechanical stress and mechanically protected.

7.2.2 WARNING / ALARM digital output

NOTE	WARNING / ALARM digital output failure
	<p>The WARNING / ALARM contact is a potential-free NO / NC contact. Using the contact with unsuitable voltages and currents will cause its failure.</p> <ul style="list-style-type: none"> Contact rating current 4 A @ 250 Vac

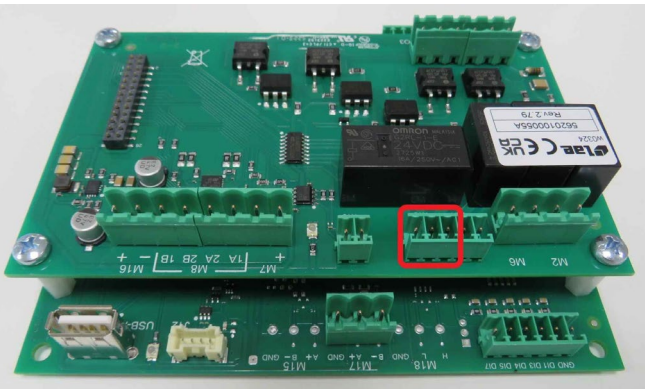
Connections	
Illustration	Description / explanation
	<ol style="list-style-type: none"> Guide a two-wires signal cable through the arranged rubber grommet on the product. Product side: connect the cable to the connector M3 [RL3] ALARM of the Electronic Control Unit. Plant side: connect the cable to the plant supervisory system. Ensure the power cable is free from mechanical stress and mechanically protected.

7.2.3 STANDBY – RUNNING digital output

NOTE	STANDBY – RUNNING digital output failure
	<p>The STANDBY – RUNNING contact is a potential-free NO contact. Using the contact with unsuitable voltages and currents will cause its failure.</p> <ul style="list-style-type: none"> Contact rating current 4 A @ 250 Vac

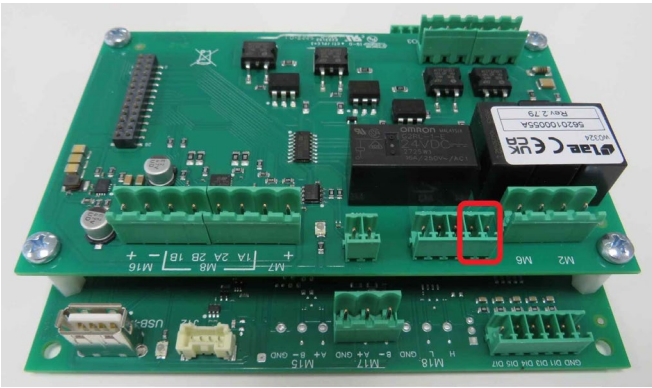
Connections	
Illustration	Description / explanation
	<ol style="list-style-type: none"> 1. Guide a two-wires signal cable through the arranged rubber grommet on the product. 2. Product side: connect the cable to the connector M4 [RL4] DRYER ON of the Electronic Control Unit. 3. Plant side: connect the cable to the plant supervisory system. 4. Ensure the power cable is free from mechanical stress and mechanically protected.

7.2.4 DEW POINT TEMPERATURE analogue output

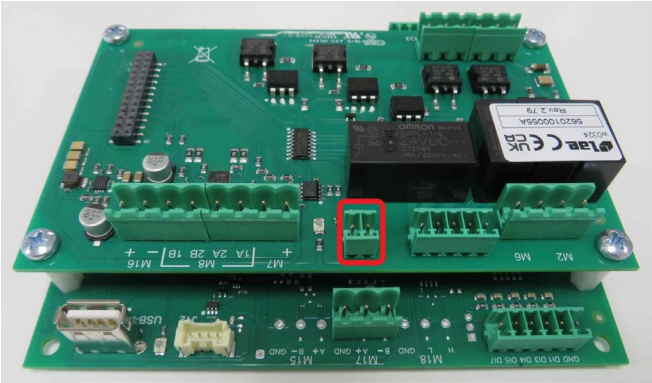
Connections	
Illustration	Description / explanation
	<ol style="list-style-type: none"> 1. Guide a two-wires shielded signal cable through the arranged rubber grommet on the product. 2. Product side: connect the cable to the connector M9 [AO3] DEW POINT of the Electronic Control Unit. 3. Plant side: connect the cable to the plant supervisory system. 4. Ensure the power cable is free from mechanical stress and mechanically protected.

7.2.5 Remote START-STOP digital input

NOTE	Remote electrical contact
	<p>Using an unsuitable remote electrical contact may cause operating malfunctions.</p> <ul style="list-style-type: none"> • Use a clean remote contact suitable for low voltage applications and free from any electrical potential. • Max resistance of contact + cable: 100 ohm.

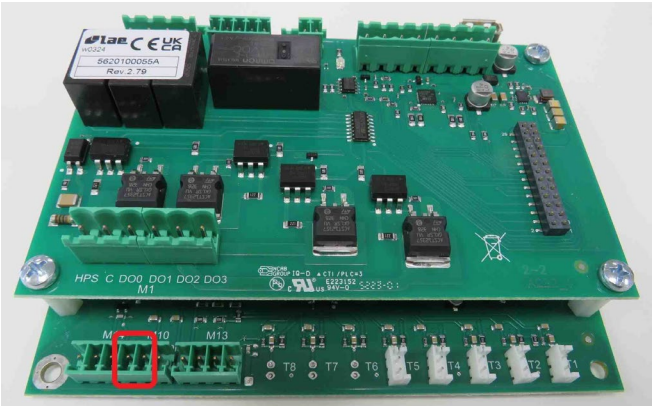
Connections	
Illustration	Description / explanation
	<ol style="list-style-type: none"> 1. Guide a two-wires signal cable through the arranged rubber grommet on the product. 2. Product side: Connect the cable to the connector M10 [DI6-GND] REMOTE of the Electronic Control Unit. 3. Plant side: connect the cable to the remote electrical contact. 4. Ensure the power cable is free from mechanical stress and mechanically protected.

7.2.6 Remote RESET digital input

NOTE	Remote electrical contact
	<p>Using an unsuitable remote electrical contact may cause operating malfunctions.</p> <ul style="list-style-type: none"> • Use a clean remote contact suitable for low voltage applications and free from any electrical potential. • Max resistance of contact + cable: 100 ohm.

Connections	
Illustration	Description / explanation
	<ol style="list-style-type: none"> 1. Guide a two-wires signal cable through the arranged rubber grommet on the product. 2. Product side: Connect the cable to the connector M10 [DI8-GND] REMOTE RESET of the Electronic Control Unit. 3. Plant side: connect the cable to the remote electrical contact. 4. Ensure the power cable is free from mechanical stress and mechanically protected.

7.2.7 USB memory stick for data log storage





Connections	
Illustration	Description / explanation
	<ol style="list-style-type: none"> 1. Insert a formatted USB memory stick into the USB slot located on the back side of the User Interface.

7.2.8 Remote management, Modbus RTU data signal

INFORMATION	Modbus RTU installation and configuration
	<p>For further information on the Modbus RTU installation and configuration, refer to section "1.3 Other applicable documents" on page 7.</p>

8. Commissioning

8.1 Warning notices

DANGER	Operation outside the permissible limit
	<p>Operation of the product or accessories outside the permissible limits and operating parameters, unauthorised work and modifications may result in death or serious injury.</p>
	<ul style="list-style-type: none"> • Observe the limits and operating parameters specified on the type plate and manual. • Check whether the operating parameters have been changed or restricted by accessories.
DANGER	Pressurised system
	<p>There is a danger of death or serious personal injury resulting from contact with fast or suddenly escaping fluids or bursting system parts.</p>
	<ul style="list-style-type: none"> • Before pressurisation, check all system pipe connections for leak tightness and tighten if necessary. • Slowly pressurise the system. • Avoid pressure blows and high differential pressures.
DANGER	Electric voltage
	<p>There is a danger of death or serious injuries if electrified components are touched. Malfunction, device failure and material damage can occur.</p>
	<ul style="list-style-type: none"> • Operate the product and accessories with the cover complete and closed and the electronics housing closed. • Check the product and accessories before commissioning under local applicable legal requirements and regulations.
WARNING	Insufficient qualification
	<p>If personnel carrying out work on the product and accessories are not properly qualified, this may result in accidents, personal injury and damage to property and impair operations.</p>
	<ul style="list-style-type: none"> • Work on the product and accessories must be carried out exclusively by skilled technical personnel specialising in pressure equipment and systems and skilled technical personnel specialising in electrical engineering.

8.2 Initial commissioning

Initial commissioning must be carried out while wearing protective equipment and after the preparatory tasks have been completed.

Prerequisites		
Tools	Material	Protective equipment
<ul style="list-style-type: none"> No tool necessary 	<ul style="list-style-type: none"> No material necessary 	

NOTE	Refrigerant compressor failure
	Starting the product with the refrigeration compressor oil still cold can irreparably damage the refrigeration compressor.
	<ul style="list-style-type: none"> Wait at least two hours before starting the product.

INFORMATION	Delayed starting function
	<p>The device has a delayed start function to avoid frequent start/stop cycles which could damage the refrigerant compressor. The start delay occurs:</p> <ul style="list-style-type: none"> After the User Interface boots up following the device being switched on. Start delay: 300 seconds. If the device is stopped using the START-STOP button and there is an attempt to immediately restart it. Start delay: 180 seconds.

INFORMATION	Dew point value
	A dew point between 0 °C (+32 °F) and +10 °C (+50 °F) displayed on the User Interface is considered to be correct under the possible operating conditions, e.g. flow rate, air inlet temperature, ambient temperature, etc.

INFORMATION	Short-term inactivity
	During short-term inactivity, max. 2 / 3 days, it is advisable to leave the product connected to the power supply and leave ON the ON-OFF switch.

Preparatory tasks

1.	Product assembly must be complete.
2.	Compressed air inlet/outlet valves must be closed.
3.	Electrical installation of the product must be complete.
4.	Section "3.1 Product overview" on page 19 must be read and applied.
5.	The condensate drain service valve must be open.

Commissioning

1.	Connect to the mains.
2.	Power the product using the ON-OFF switch and wait 30 seconds for the User Interface to reboot. Refer to section "3.1 Product overview" on page 19.
3.	Wait two hours to allow the compressor refrigerant oil to heat up.
4.	Water-cooled models: connect the cooling water supply.
5.	Water-cooled models: check the regular water flow in the water circuit.
6.	Start the product pushing for three seconds the START-STOP button on the User Interface. Refer to section " 9.3 Overview of User Interface after power ON " on page 63.
7.	If the product does not start and the User Interface shows the alarm A14, stop commissioning and refer to section "7.2.1 External power supply" on page 54.
8.	Check the power consumption complies with the values engraved on the type plate.
9.	Wait for the cooling fan to run.
10.	Wait until the dew point value displayed on the User Interface is stable. Refer to section " 9.4 Operate on the User Interface " on page 63.
11.	Connect the compressed air supply.
12.	Slowly open the air inlet valve.
13.	Slowly open the air outlet valve.
14.	Check the air connections for air leakage.
15.	Wait for the condensate drain to work.
16.	Check the condensate drain works correctly.

9. Operation

9.1 Warning notices

DANGER	Operation outside the permissible limit
	<p>Operation of the product or accessories outside the permissible limits and operating parameters, unauthorised work and modifications may result in death or serious injury.</p> <ul style="list-style-type: none"> • Observe the limits and operating parameters specified on the type plate and manual. • Observe the assembly and ambient conditions. • Check whether the operating parameters have been changed or restricted by accessories. • Comply with maintenance intervals.

DANGER	Electric voltage
	<p>There is a danger of death or serious injuries if electrified components are touched. Malfunction, device failure and material damage can occur.</p> <ul style="list-style-type: none"> • Operate the product and accessories with the cover complete and closed and the electronics housing closed.

NOTE	Operating personnel
	<p>Insufficient knowledge of the product and accessories can lead to damage to property, the environment and impair operations.</p> <ul style="list-style-type: none"> • The product and accessories may only be operated and used by qualified operating personnel.

9.2 Daily operating checks

With the product in normal running condition, perform the following daily checks:

- Dew point value stability.
- Functioning of condensate drain.
- Condenser cleanliness
- Cyclical run/stop of the cooling fan.
- Noiseless of normal running condition.

9.3 Overview of User Interface after power ON

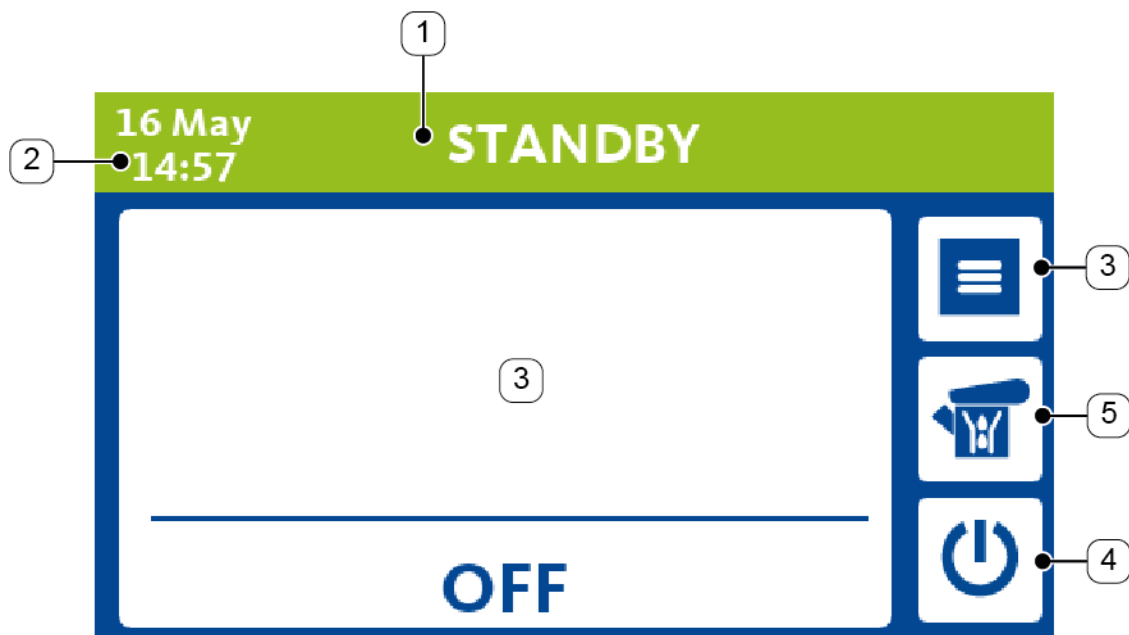

Pos. No.	Description / explanation
[1]	Device status and notification area
[2]	Current date and time
[3]	Dew point temperature area

Pos. No.	Description / explanation
[4]	START-STOP button
[5]	CONDENSATE DRAIN TEST button
[6]	FUNCTIONS MENU button

9.4 Operate on the User Interface

For product operation, preparatory tasks must have been completed.

Preparatory tasks	
1.	The procedure on section "8 Commissioning" on page 59 must be carried out.
2.	The product must be switched ON and started.
3.	Compressed air flows into the air circuit.
4.	Water-cooled models: cooling water flows into the water circuit.
5.	The condensate is regularly discharged.

9.4.1 Normal running status

INFORMATION	Dew point value
	<p>A dew point between 0 °C (+32 °F) and +10 °C (+50 °F) displayed on the User Interface is considered to be correct under the possible operating conditions, e.g. flow rate, air inlet temperature, ambient temperature, etc.</p>

INFORMATION	Refrigerant compressor running
	<p>During the normal running status, the refrigerant compressor runs continuously. The product must remain started during the entire compressed air usage time, even if the air compressor works periodically.</p>

Illustration	Description / explanation
 <p>The screenshot shows a digital display with a green header bar containing the date and time '16 May 15:25' and the status 'ON'. The main display area shows a large '3.5 °C' and 'PDP' below it. On the right side, there are three icons: a menu icon, a fan icon, and a power icon.</p>	<p>Normal running status</p> <p>The User Interface shows:</p> <ul style="list-style-type: none"> • current date and time • Status ON with green background • dew point temperature

9.4.2 Stopping and starting

INFORMATION	Delayed starting function
	<p>The device has a delayed start function to avoid frequent start/stop cycles which could damage the refrigerant compressor. The start delay occurs:</p> <ul style="list-style-type: none"> • After the User Interface boots up following the device being switched on. • Start delay: 300 seconds. • If the device is stopped using the START-STOP button and there is an attempt to immediately restart it. Start delay: 180 seconds.

Illustration	Description / explanation
	<p>Stopping the device</p> <ol style="list-style-type: none"> 1. Press and hold the START-STOP button [1] for three seconds. <ul style="list-style-type: none"> → The device stops. → The User Interface shows STANDBY.
	<p>Starting the device</p> <ol style="list-style-type: none"> 1. Press and hold the START-STOP button [1] for three seconds. <ul style="list-style-type: none"> → The device starts. → The User Interface shows ON and the dew point temperature.

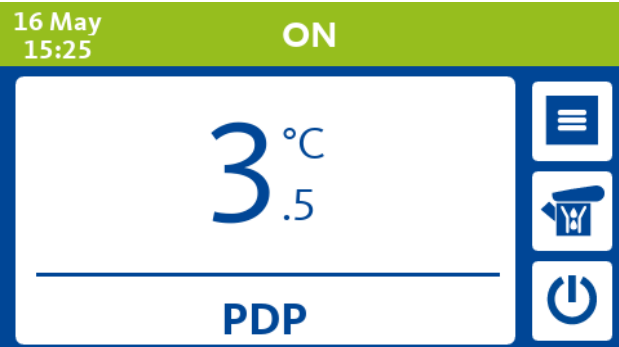
9.4.3 Condensate drain test

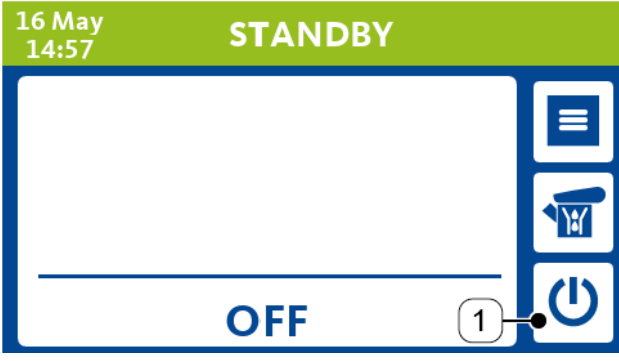
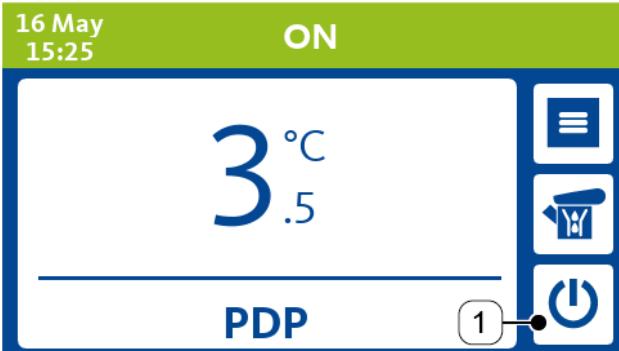

INFORMATION	Condensate drain test
	The condensate drain test can be performed at any time, regardless of the device status and any display indication.

Illustration	Description / explanation
 <p>The illustration shows a digital display with a green header bar containing the date '16 May' and time '15:25' on the left, and the status 'ON' on the right. The main display area shows a large temperature reading of '3.5 °C'. Below the temperature is a horizontal line and the text 'PDP'. On the right side of the display, there is a vertical column of three icons: a menu icon (three horizontal lines), a trash can icon with a '1' in a circle pointing to it, and a power icon (a circle with a vertical line through it).</p>	<p>Condensate drain test</p> <ol style="list-style-type: none"> 1. Press and hold the CONDENSATE DRAIN TEST button [1] to perform the condensate drain test, release the button to stop the test.

9.4.4 Actual process values, data logger, data recording

Illustration	Description / explanation
	<p>Actual process values</p> <ol style="list-style-type: none"> 1. With the device in normal running status, press the FUNCTIONS MENU button [1] to access the functions menu screen.
	<ol style="list-style-type: none"> 2. Press the PROCESS VALUES button [2] to access the actual process values screen. 3. From each subsequent screen, to return back to previous screen, press the BACK button [3].

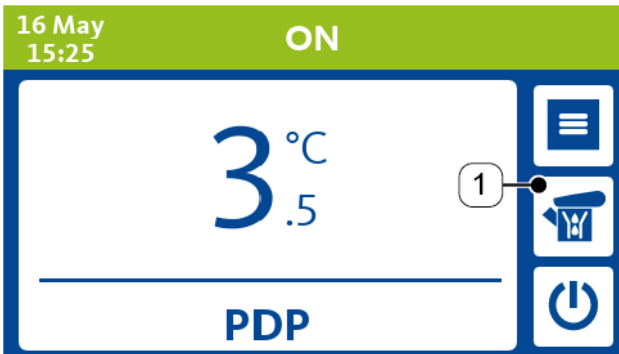
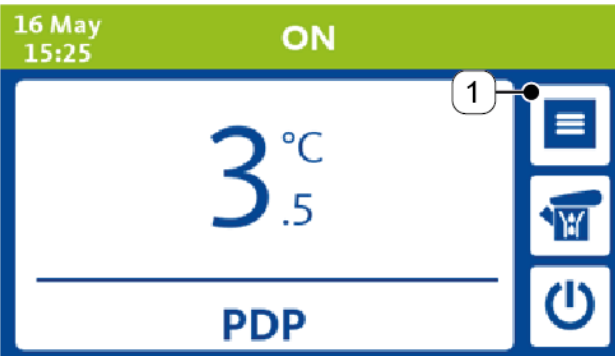
Illustration

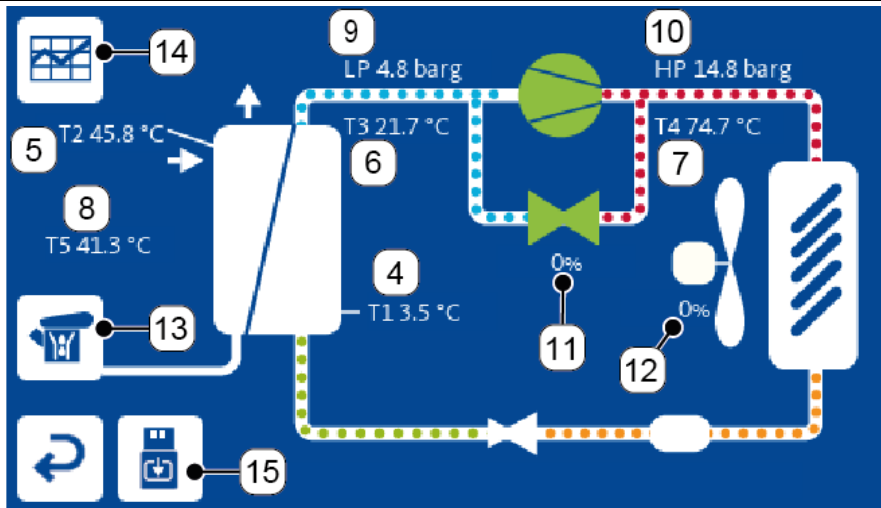

Pos. No.	Description / explanation	Pos. No.	Description / explanation
[4]	T1 – Dew point temperature.	[10]	HP – Pressure of refrigerant fluid at compressor discharge side.
[5]	T2 – Air temperature at heat exchanger inlet side.	[11]	Opening percentage of hot gas by-pass valve, models RA 2400 / 3000.
[6]	T3 – Refrigerant fluid temperature at compressor suction side.	[12]	Fan speed percentage, models RA 2400 / 3000.
[7]	T4 – Refrigerant fluid temperature at compressor discharge side.	[13]	CONDENSATE DRAIN TEST button
[8]	T5 – Ambient temperature.	[14]	PROCESS VALUES HISTORY button
[9]	LP – Refrigerant fluid pressure at compressor suction side.	[15]	DATA RECORDING button

Description / explanation

The User Interface shows the actual process values and related function buttons.

CONDENSATE DRAIN TEST button

Press and hold the **CONDENSATE DRAIN TEST** button **[13]** to perform the condensate drain test, release the button to stop the test

PROCESS VALUES HISTORY button

Press the **PROCESS VALUES HISTORY** button **[14]** to access the process values history screen.

DATA RECORDING button

Press the **DATA RECORDING** button **[15]** to access the data recording screen.

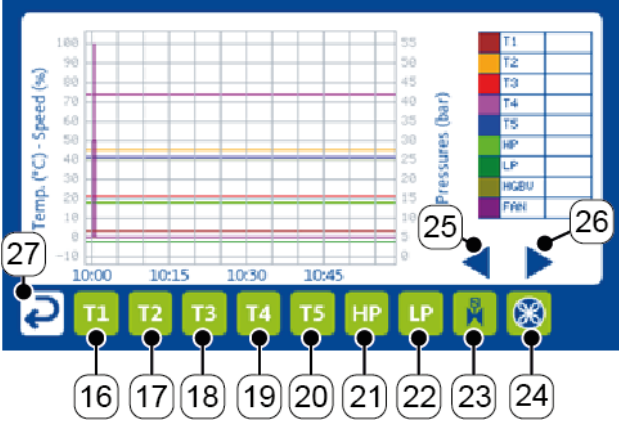
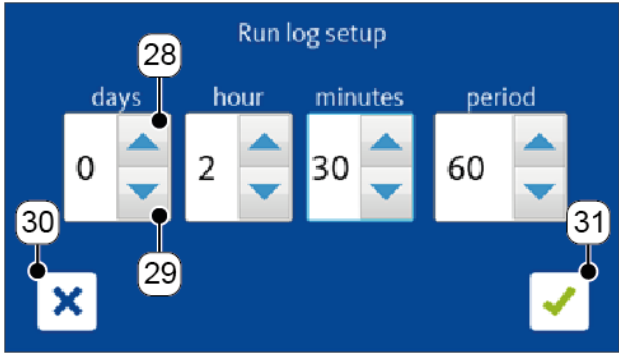
Description / explanation	
	<p>Process values history screen</p> <p>Graphical and numerical representation of actual process values for the last 60 minutes of device operation.</p> <p>Stored values shifted out the last 60 minutes are lost.</p> <ol style="list-style-type: none"> 1. Use buttons T1 [16], T2 [17], T3 [18], T4 [19], T5 [20], HP [21], LP [22], EHGBV [23], FAN [24] to show / hide the corresponding traces on the graph. 2. Touch the graph to position the graph cursor roughly near the required time. 3. Use the CURSOR L and CURSOR R buttons [25, 26] to fine tune the position of the graph cursor on the required time. Positioning accuracy is +/- 15 seconds. 4. Press the BACK button [27] to return to the previous screen.
	<p>Data recording screen</p> <p>To record the process values of a certain time frame, a USB memory stick must be installed by the maintenance personnel. Refer to section "7.2.7 USB memory stick for data log storage" on page 58.</p> <ol style="list-style-type: none"> 1. Set the recording time with the CURSOR UP and CURSOR DOWN buttons [28, 29]. The picture shows a setting of recording time for two hours and 30 minutes with a data sampling every 60 seconds. 2. Start the recording by pressing the CONFIRM button [31] or abort the command by pressing EXIT [30].

Description / explanation	
	<ol style="list-style-type: none"> 3. The User Interface shows the time remaining to the end of recording. 4. To manually stop the recording, press the STOP DATA RECORDING button [32].
	<ol style="list-style-type: none"> 5. Stop the recording by pressing the CONFIRM button [31] or abort the command pressing EXIT [30]. 6. Once the recording is finished, the USB memory stick must be removed for further analysis. <p>The USB memory stick must be removed by the maintenance personnel.</p>

9.4.5 WARNING status

A WARNING is an anomalous event related to a device malfunction. WARNINGS do not compromise device functioning or operator safety.

NOTE	WARNING status
	<p>With the device in WARNING status the compressed air treatment may be incorrect.</p> <ul style="list-style-type: none"> • Call maintenance personnel immediately if one or more WARNINGS are detected. • Maintenance personnel will refer to section "16 Troubleshooting" on page 108.

INFORMATION	Device behaviour when there is a WARNING
	<ul style="list-style-type: none"> • With the stopped device: <ul style="list-style-type: none"> → Triggered WARNINGS are not shown on the User Interface. → The device can be started if there are active WARNINGS. • After the starting command: <ul style="list-style-type: none"> → The device starts. → The User Interface notification area changes colour to orange and flashes. → WARNING code and text are shown in the notification area. → If there are multiple active WARNINGS, they are shown cyclically. • With the device in normal running status: <ul style="list-style-type: none"> → The device remains in normal running status. → The User Interface notification area changes colour to orange and flashes. → WARNING code and text are shown in the notification area. → If there are multiple active WARNINGS, they are shown cyclically. • Exceptions: <ul style="list-style-type: none"> → WARNING W11 appears and automatically clears without any user clearing action, with device stopped. → WARNING W5 appears and automatically clears by factory setting. It can be set to be cleared with the user clearing action. → WARNING W2 doesn't stop the dryer by factory setting. It can be set: <ul style="list-style-type: none"> ○ to prevent starting the device, if stopped. ○ to stop the device, if started.

WARNING Code	Description / explanation
W1	Low Dew Point
W2	High Dew Point
W3	Probe Fault T2
W4	Probe Fault T3
W5	Drainer
W5 Dn nn	Drainer, specific faults
W6	Programmed Service
W7	High Discharge Temperature
W8	High Evaporating Pressure
W9	Low Condensing Pressure
W10	High Condensing Pressure
W11	Low Ambient Temperature
W12	High Ambient Temperature
W13	Probe Fault T5
W14	Low Inlet Temperature
W15	High Inlet Temperature

Illustration	Description / explanation
	<p>e.g. WARNING W3: PROBE FAULT T2</p> <ol style="list-style-type: none"> 1. The notification area changes colour to orange and flashes. 2. WARNING code W3 and text PROBE FAULT T2 are shown.

9.4.6 ALARM status

An ALARM is an anomalous event related to a device malfunction or fault. An ALARM stops the device to ensure device and operator safety.

NOTE	ALARM status
	<p>With the device in ALARM status the compressed air will not be treated.</p> <ul style="list-style-type: none"> • Call maintenance personnel immediately if one or more ALARMS are detected. • Maintenance personnel will refer to section "16 Troubleshooting" on page 108.

INFORMATION	Device behaviour when there is an ALARM
	<ul style="list-style-type: none"> • With the stopped device: <ul style="list-style-type: none"> → Triggered ALARMS are not shown on the User Interface. → The device cannot be started if there are active ALARMS. • After the starting command: <ul style="list-style-type: none"> → The device doesn't start. → The User Interface notification area shows ALARM, changes colour to red and flashes. → ALARM code and text are shown in the notification area. → If there are multiple active ALARMS, they are shown cyclically. • With the device in normal running status: <ul style="list-style-type: none"> → The device stops immediately. → The User Interface notification area shows ALARM, changes colour to red and flashes. → ALARM code and text are shown in the notification area. → If there are multiple active ALARMS, they are shown cyclically. • Exceptions: <ul style="list-style-type: none"> → ALARMS A6 and A14 appear with the stopped device.

ALARM Code	Description / explanation
A1	High Pressure Switch
A2	Low Pressure Switch
A3	Low Evaporating Pressure
A4	High Discharge Temperature
A5	Compressor protection
A6	ICE
A7	Probe Fault LP
A8	Probe Fault HP
A9	Probe Fault T1
A10	Probe Fault T4
A11	Low Differential Pressure
A12	High Evaporating Pressure
A13	Low condensing Pressure
A14	Reversed Phases
A19	Fan
A E 1001	Power Unit Communication Lost

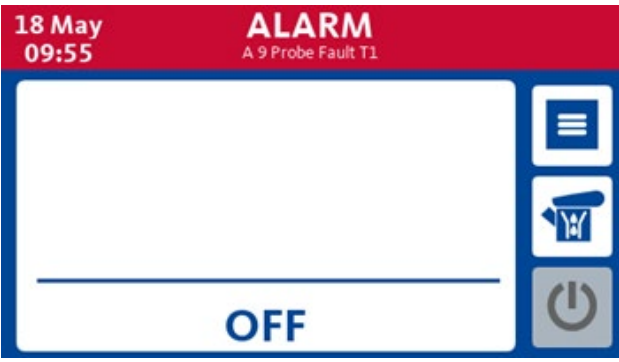
Illustration	Description / explanation
	<p>e.g. ALARM A9: PROBE FAULT T1</p> <ol style="list-style-type: none"> 1. The notification area shows ALARM, changes colour to red and flashes. 2. ALARM code A9 and text PROBE FAULT T1 are shown.

9.4.7 ALARM history

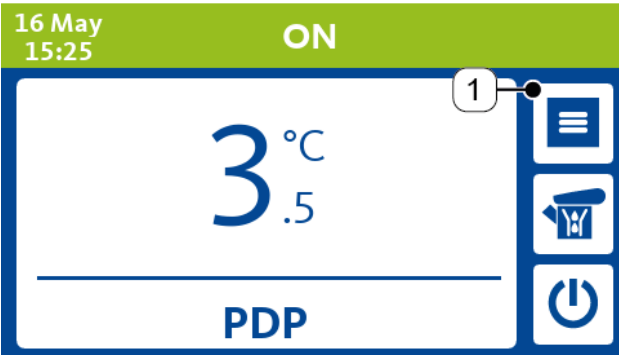

Illustration	Description / explanation
	<p>ALARM history</p> <ol style="list-style-type: none"> 1. With the device stopped or in normal running status, press the FUNCTIONS MENU button [1] to access the functions menu screen.
	<ol style="list-style-type: none"> 2. Press the ALARM HISTORY button [2] to access the alarm history file screen. 3. From each subsequent screen it is possible to return to the previous screen by pressing the BACK button [3].

Illustration	Description / explanation																
 <p>The screenshot shows a table with the following data:</p> <table border="1"><thead><tr><th>Code</th><th>Start</th><th>End</th><th>Description</th></tr></thead><tbody><tr><td>A 14</td><td>18/05 14:15</td><td>18/05 14:33</td><td>Reversed Phases</td></tr><tr><td>A 2</td><td>18/05 14:12</td><td>18/05 14:12</td><td>Low Pressure switch</td></tr><tr><td>A 1</td><td>18/05 13:55</td><td>18/05 13:55</td><td>High Pressure switch</td></tr></tbody></table> <p>Callout 4 points to the up arrow button on the right side of the table. Callout 5 points to the down arrow button. Callout 6 points to the 'DATA RECORDING' button (a USB stick icon) at the bottom right of the screen.</p>	Code	Start	End	Description	A 14	18/05 14:15	18/05 14:33	Reversed Phases	A 2	18/05 14:12	18/05 14:12	Low Pressure switch	A 1	18/05 13:55	18/05 13:55	High Pressure switch	<p>4. Use the CURSOR UP and CURSOR DOWN buttons [4, 5] to scroll the chronological list of ALARMS.</p> <p>ALARM history download</p> <p>To download the ALARM history, a USB memory stick must be installed by maintenance personnel. Refer to section "7.2.7 USB memory stick for data log storage" on page 58.</p> <p>5. Press the DATA RECORDING button [6] to download the entire ALARM history.</p>
Code	Start	End	Description														
A 14	18/05 14:15	18/05 14:33	Reversed Phases														
A 2	18/05 14:12	18/05 14:12	Low Pressure switch														
A 1	18/05 13:55	18/05 13:55	High Pressure switch														
 <p>The screenshot shows a confirmation dialog box with the text "Do you want to save the alarm log?". Callout 7 points to the 'EXIT' button (a blue 'X' icon) on the left. Callout 8 points to the 'CONFIRM' button (a green checkmark icon) on the right.</p>	<p>6. Confirm the download by pressing the CONFIRM button [8] or abort the command by pressing EXIT [7].</p> <p>7. Once the downloading is finished, remove the USB memory stick for further analysis.</p> <p>The USB memory stick must be removed by the maintenance personnel.</p>																

9.4.8 Remote mode



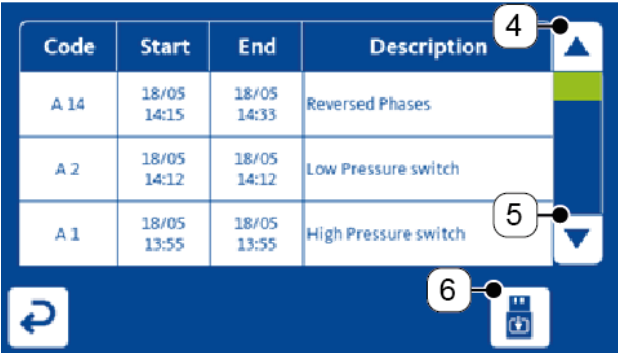
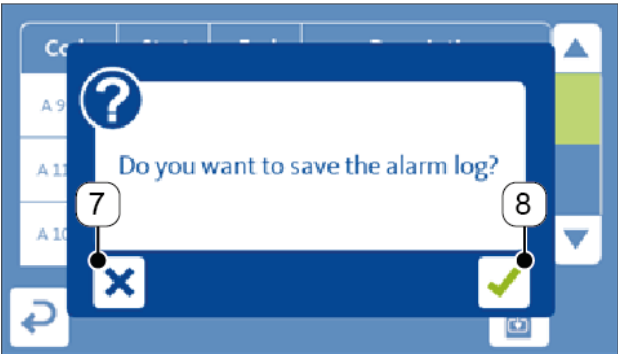

INFORMATION	Device behaviour in remote mode
	<ul style="list-style-type: none"> • The device starts and stops by a remote command without any preliminary signalling on the local User Interface. • Operations not permitted on the local User Interface: • Starting and stopping the device. • Operations permitted on the local User Interface: • Access to the functions menu. • Managing and clearing WARNINGS and ALARMS. • Condensate drain test. • Operations permitted by remote command: • Starting and stopping the device • Clearing WARNINGS and ALARMS. • Exceptions <ul style="list-style-type: none"> → WARNINGS and ALARMS can be cleared on the local User Interface or by remote command using factory settings. This feature can be changed to clear WARNINGS and ALARMS only on the local User Interface.

Illustration	Description / explanation
 <p>The screenshot shows a user interface with a green header bar containing the date '19 May' and time '08:40'. Below the header, the text 'REMOTE STANDBY' is displayed in large, bold letters. At the bottom of the screen, the word 'OFF' is shown. On the right side, there is a vertical menu with three icons: a list icon, a trash can icon, and a power icon.</p>	<p>Remote mode</p> <ul style="list-style-type: none"> • The device is stopped. • The User Interface shows REMOTE STANDBY.
 <p>The screenshot shows a user interface with a green header bar containing the date '19 May' and time '08:40'. Below the header, the text 'REMOTE ON' is displayed in large, bold letters. In the center, the temperature '3.5 °C' is shown. At the bottom of the screen, the text 'PDP' is displayed. On the right side, there is a vertical menu with three icons: a list icon, a trash can icon, and a power icon.</p>	<ul style="list-style-type: none"> • The device is started. • The User Interface shows REMOTE ON.

9.4.9 Operating hours and maintenance timer

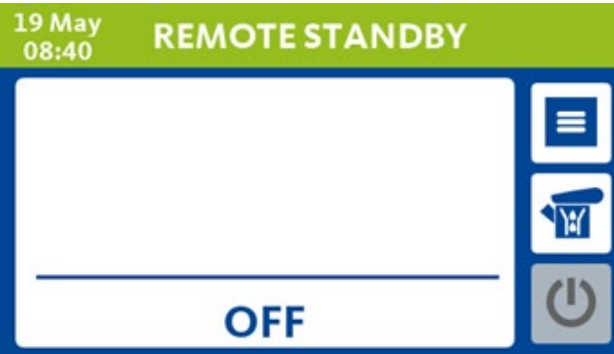
Illustration	Description / explanation
	<p>Operating hours and maintenance timer</p> <ol style="list-style-type: none"> 1. With the device stopped or in normal running status, press the FUNCTIONS MENU button [1] to access the functions menu screen.
	<ol style="list-style-type: none"> 2. Press the OPERATING HOURS button [2] to access the information screen. 3. From each subsequent screen it is possible to return to the previous screen by pressing the BACK button [3].
	<ol style="list-style-type: none"> 4. The User Interface shows: <ul style="list-style-type: none"> - Total operating hours. - Remaining hours to the next maintenance. - Operating hours from last timer reset. <p>MAINTENANCE TIMER RESET button</p> <ol style="list-style-type: none"> 5. The MAINTENANCE TIMER RESET button [4] is used by maintenance personnel only. To avoid incorrect operations, its function is protected by a security PIN. Refer to section "10.2.1 Maintenance timer reset" on page 91.

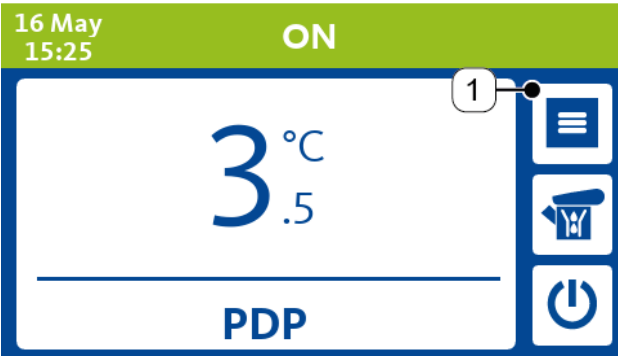
9.4.10 System settings and automatic start/stop weekly timer

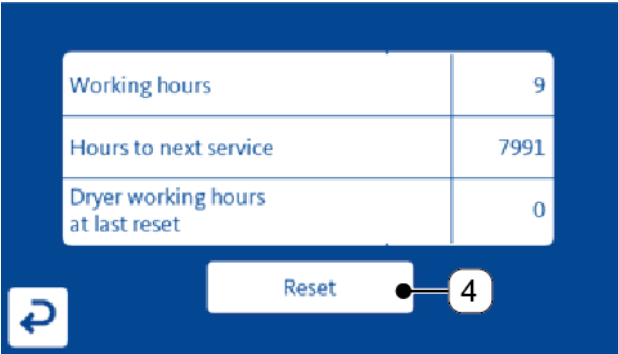
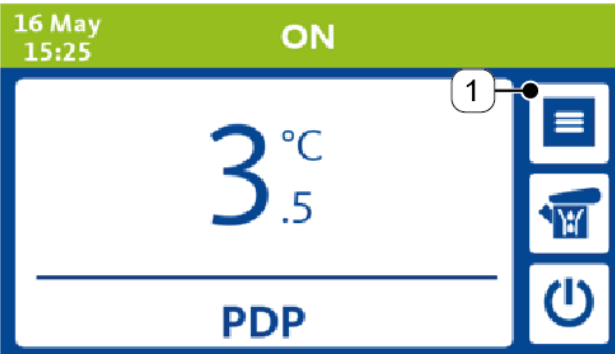

Illustration	Description / explanation
	<p>System settings and automatic start/stop weekly timer</p> <ol style="list-style-type: none"> 1. With the device stopped or in normal running status, press the FUNCTIONS MENU button [1] to access the functions menu screen.
	<ol style="list-style-type: none"> 2. Press the SYSTEM SETTINGS button [2] to access the system settings screen. 3. From each subsequent screen it is possible to return to the previous screen by pressing the BACK button [3].
	<ol style="list-style-type: none"> 4. The User Interface shows: <ul style="list-style-type: none"> → System language → Current date → Current time → Date format → Time format → Units of temperature and pressure 5. Touch the desired function and change / update the settings / values. <p>Weekly timer setup</p> <ol style="list-style-type: none"> 6. Press the TIMER SETUP button [4] to access the weekly timer screen.

Illustration		Description / explanation
<p>Green colour areas = Programmed running time and timer enabled.</p> <p>Light blue areas = Programmed running time and timer disabled.</p> <p>White areas = device stopped.</p>		<ol style="list-style-type: none"> 7. Touch the screen to set the automatic start / stop time for the device. The set running time is highlighted by colouring the selected areas in green or blue. 8. Select / unselect the boxes on the left of the screen to exclude / include one or more days in the settings. 9. Select / unselect the ENABLED box [5] to enable / disable the timer.

9.4.11 Device spare parts list

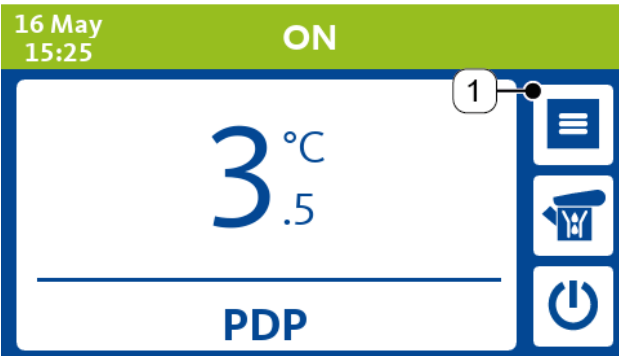

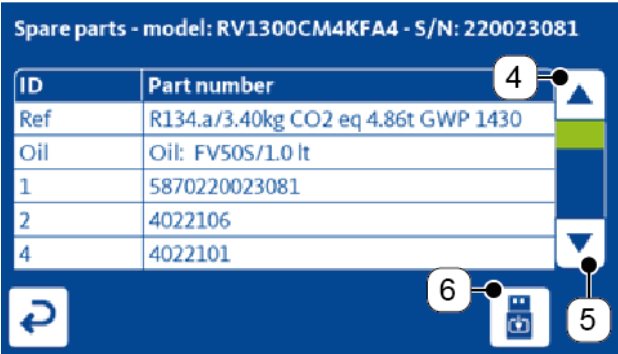
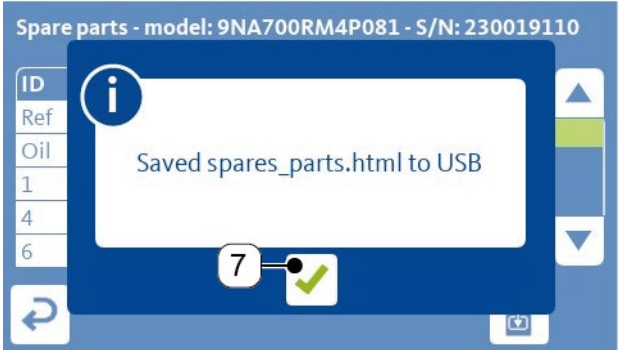

Illustration	Description / explanation
	<p>Device spare parts list</p> <ol style="list-style-type: none"> 1. With the device stopped or in normal running status, press the FUNCTIONS MENU button [1] to access the functions menu screen.
	<ol style="list-style-type: none"> 2. Press the SPARE PARTS LIST button [2] to access the screen of the device spare parts list. 3. From each subsequent screen it is possible to return to the previous screen by pressing the BACK button [3].

Illustration	Description / explanation
	<p>4. Use the CURSOR UP and CURSOR DOWN buttons [4, 5] to scroll the spare parts list.</p> <p>Spare parts list download</p> <p>To download the spare parts list, a USB memory stick must be already installed by maintenance personnel. Refer to section "7.2.7 USB memory stick for data log storage" on page 58.</p> <p>5. Press the DATA RECORDING button [6] to download the spare parts list.</p>
	<p>6. Once the downloading is finished, press the CONFIRM button [7] and remove the USB memory stick for further analysis.</p> <p>The USB memory stick must be removed by the maintenance personnel.</p>

9.4.12 User parameters

NOTE	Incorrect setting of user parameters
	<p>Incorrect setting of user parameters can lead to unexpected device behaviour like improper air treatment due to a wrong dew point, unexpected start and stop, unexpected signalling of one or more warnings / alarms, condensate drain malfunction, breakdown of Modbus communication.</p> <ul style="list-style-type: none"> • Default user parameters must be carefully modified, following the compressed air plant specifications and requirements.

Code	Description / explanation	Value range	Accuracy	Default value
Ton	Time drain ON Condensate drain, solenoid valve activation time. 0 = BEKOMAT® drain installed	0 ... 20 seconds	1	0
Toff	Time drain OFF Condensate drain, solenoid valve pause time.	0 ... 20 minutes	1	1
DrC	Dryer Remote Control LOCAL = local START-STOP mode REMOTE = remote START-STOP via digital input signal MODBUS = remote START-STOP via Modbus RTU.	LOCAL, REMOTE, MODBUS	-	LOCAL
HdA	High Dew Point Alarm W2 Warning threshold temperature	0.0 ... 25.0 °C or 32.0 ... 77.0 °F	0.1	20.0 °C or 68.0 °F
Hdd	High Dew Point Delay W2 Warning triggering delay time	1 ... 20 minutes	1	15
HdS	High Dew Point alarm STOP Device behaviour during normal running status with W2 Warning active NO = device doesn't stop YES = device stops	NO, YES	-	NO
SrV (*1)	Service settings Maintenance timer setting 0.0 = timer disabled	0.0 ... 12.0 (x 1000) hours	0.1	8.0
ScL	Units °C = temperature in °C and pressure in bar °F = temperature in °F and pressure in psi	°C, °F	-	°C

(*1) With advanced parameter **PSPR** = YES, the **SrV** parameter can be modified only after typing the security PIN.

Code	Description / explanation	Value range	Accuracy	Default value
AS	<p>Auto Restart</p> <p>Automatic restart after a voltage drop</p> <p>NO = device must be intentionally restarted</p> <p>YES = device restarts automatically, if it was running before voltage drop</p>	NO, YES	-	NO
Ard	<p>Auto Reset service drain</p> <p>Enables / disables the automatic clearing of W5 Warning</p> <p>YES = automatic clearing</p> <p>NO = manual clearing</p>	YES, NO	-	YES
ACM	<p>Alarm Contact Management</p> <p>Selects the triggering logic of the WARNING / ALARM contact</p> <p>1 = any Alarm and W2 Warning</p> <p>2 = any Alarm and any Warning</p> <p>3 = any Alarm</p> <p>4 = any Alarm and W2 and W11 Warnings</p>	1, 2, 3, 4	-	1
IPA	Modbus address	1 ... 255	1	1
DPmin	<p>Dew Point at 4mA</p> <p>Minimum Dew Point value that sets the analogue output AO3 to 4 mA</p>	-10.0 ... 10.0 °C or 14.0 ... 50.0 °F	0.1	-10.0 °C or 14.0 °F
DPmax	<p>Dew Point at 20mA</p> <p>Maximum Dew Point value that sets the analogue output AO3 to 20 mA</p>	25.0 ... 50.0 °C or 77.0 ... 122.0 °F	0.1	40.0 °C or 104.0 °F

Advanced parameters, protected by security PIN

Code	Description / explanation	Value range	Accuracy	Default value
RbP (*2)	<p>Reset by Password</p> <p>Clearing WARNINGS / ALARMS</p> <p>NO = clearing allowed locally (by User Interface) and remotely</p> <p>YES = clearing allowed locally (by User Interface)</p>	NO, YES	-	NO
NoA (*3)	<p>Number of Alarms</p> <p>Maximum number of local clearings allowed within the time frame defined in TtPR</p>	1 ... 10	1	1
TtPR (*3) (*4)	<p>Time to Possible Reset</p> <p>Time frame within which the maximum number of local clearings defined in NoA can be performed</p>	0 ... 24 hours	1	1
PSPR	<p>Programmed Service Protected Reset</p> <p>Enables / disables the security PIN to clear the W6 Warning</p> <p>NO = clearing of Warning allowed without typing the security PIN</p> <p>YES = clearing of Warning allowed only after typing the security PIN</p>	NO, YES	-	NO

(*2) With **RbP** = NO, the maximum number of remote clearings allowed within 60 minutes is three.

(*3) Effective only with **RbP** = YES.

(*4) With **TtPR** = 0, when **NoA** setting is reached, the device asks the security PIN to clear a WARNING / ALARM.

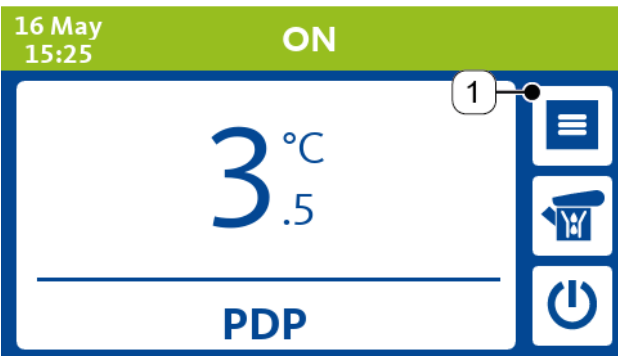

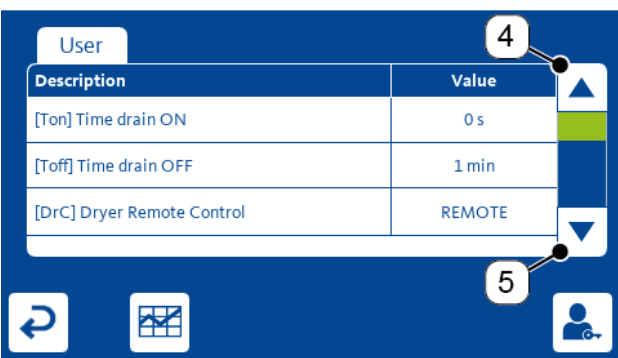
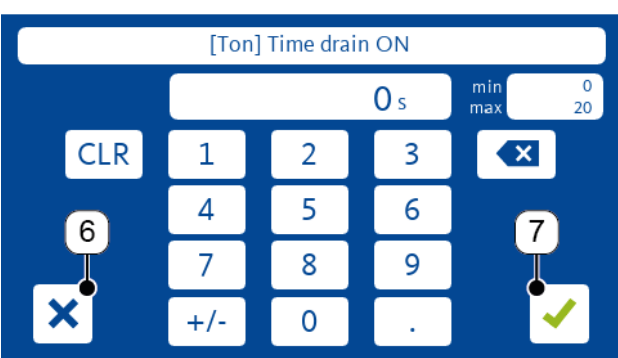
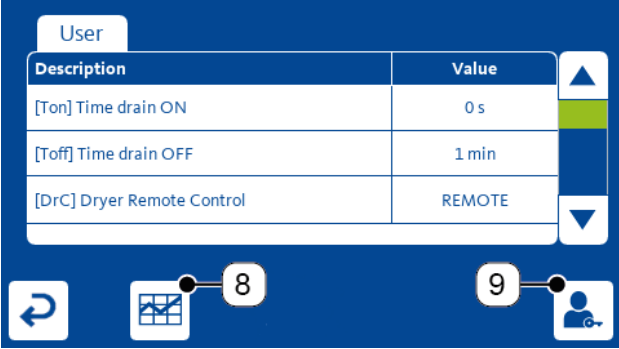

Illustration	Description / explanation
	<p>Parameter modification</p> <ol style="list-style-type: none"> 1. With the device stopped or in normal running status, press the FUNCTIONS MENU button [1] to access the functions menu screen.
	<ol style="list-style-type: none"> 2. Press the PROCESS PARAMETERS button [2] to access the user parameters screen. 3. From each subsequent screen it is possible to return to the previous screen by pressing the BACK button [3].
	<ol style="list-style-type: none"> 4. Use the CURSOR UP and CURSOR DOWN buttons [4, 5] to scroll the parameters list. 5. Touch the screen on the parameter to be changed then select the desired value.
	<ol style="list-style-type: none"> 6. If the parameter requires a numerical value, set the new value using the numerical keypad. 7. Confirm the new setting by pressing the CONFIRM button [7] or abort the command by pressing the EXIT [6].

Illustration	Description / explanation
	<p>ADVANCED PROCESS PARAMETERS button</p> <p>8. Press the ADVANCED PROCESS PARAMETERS button [9] to access the advanced parameters screen. To avoid incorrect operations, the access is protected by a security PIN.</p> <p>PROCESS VALUES HISTORY button</p> <p>9. Press the PROCESS VALUES HISTORY button [8] to access the compressor envelope screen. To avoid incorrect operations, the access is protected by a security PIN.</p>



9.4.13 Modbus function





The Modbus function can be used to manage the operating functions and device information.

INFORMATION	Modbus configuration
	<p>For further information on the Modbus function, refer to section "1.3 Other applicable documents" on page 7.</p>

10. Maintenance

10.1 Warning notices

DANGER	Pressurised system
	<p>There is a danger of death or serious personal injury resulting from contact with fast or suddenly escaping fluids or bursting system parts.</p>
	<ul style="list-style-type: none"> • Before starting work, depressurise the system and secure it against unintentional pressurisation. • Set up a safety area around the working area during assembly, installation, maintenance and repair work. • Assemble pipes and hoses free from mechanical stress. • Before pressurisation, check all system connections for leak tightness and tighten if necessary. • Slowly pressurise the system. • Avoid pressure blows and high differential pressures.
DANGER	Electric voltage
	<p>There is a danger of death or serious injuries if electrified components are touched. Malfunction, device failure and material damage can occur.</p>
	<ul style="list-style-type: none"> • Carry out installation, maintenance and repair work on the product and accessories when they have been disconnected and secured against being accidentally switched on. • Set up a safety area around the working area during assembly, installation, maintenance and repair work.
DANGER	Incorrect spare parts, accessories or materials
	<p>Using the incorrect spare parts, accessories or materials, and auxiliary and operating materials, may result in death or serious injury. Malfunctions, device failure and material damage can occur.</p>
	<ul style="list-style-type: none"> • Use undamaged original parts, auxiliary and operating materials which are specified by the manufacturer to complete work. • Use the materials approved for the related application and tools that are working properly. • Use pipes that are free from dirt, damage and corrosion. • Use electrical components and materials that comply with local applicable specifications and regulations for electrical safety.

WARNING	Refrigerant fluid
	<p>The incorrect handling of refrigerant fluid may result in serious injury. Malfunctions, device failure and environment damage can occur. Refer to the product type plate for the type and amount of refrigerant fluid in the product.</p>
	<ul style="list-style-type: none"> • Work on the product and accessories must be carried out exclusively by skilled technical personnel specialising in refrigeration engineering and customer service.
WARNING	Hot surfaces
	<p>Contact with hot surfaces during work on the product and accessories can lead to burns, accidents and personal injury.</p>
	<ul style="list-style-type: none"> • Switch the product OFF before maintenance and allow it to cool.
WARNING	Insufficient qualification
	<p>If personnel carrying out work on the product and accessories are not properly qualified, this may result in accidents, personal injury and damage to property and impair operations.</p>
	<ul style="list-style-type: none"> • Work on the product and accessories must be carried out exclusively by skilled technical personnel specialising in customer service.
WARNING	Entry of moisture or foreign bodies
	<p>Removing components or opening the product may allow water or foreign bodies to enter the product. Entry of water or foreign bodies can lead to accidents, personal injury, damage to property and impair operation.</p>
	<ul style="list-style-type: none"> • Protect the product against water splashes or moisture. • Open the product or remove components in a dry place. • Do not insert any foreign bodies into product openings. • Keep contact surfaces and openings free from dirt and moisture.
CAUTION	Condensate
	<p>Contact with condensate containing substances which endanger health and the environment can pose a health hazard, causing irritation or damage to the eyes, skin and mucous membranes.</p>
	<ul style="list-style-type: none"> • Use suitable protective equipment when handling condensate. • Pick up and dispose of any leaking or spilled condensate under applicable regional laws and requirements.

10.2 Maintenance

Maintenance must be carried out while wearing the following protective equipment and after the preparatory tasks have been completed.





Prerequisites		
Tools	Material	Protective equipment
<ul style="list-style-type: none"> No tool necessary 	<ul style="list-style-type: none"> No material necessary 	

Preparatory tasks	
1.	The procedure on section "13 Decommissioning" on page 100 must be carried out.

Maintenance	Interval
<ul style="list-style-type: none"> Clean the condenser using an air jet, max. 2 bar (29 psi), inside out. 	200 hours or monthly, depending on which occurs first.
<ul style="list-style-type: none"> Check the electrical connections tightness. Check the electrical cables insulation integrity. Check the electrical clamps integrity. Check the electrical equipment fasteners integrity. Check the refrigeration circuit for signs of oil or refrigerant leaks. Check the condensate drain rubber hose integrity. 	1000 hours or annually, depending on which occurs first.
<ul style="list-style-type: none"> Check / clean / replace the condensate drain. 	8000 hours.

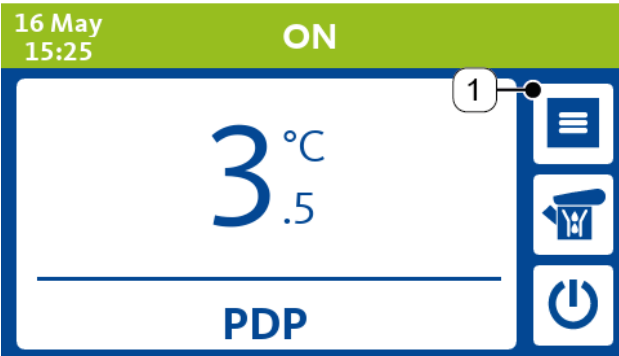

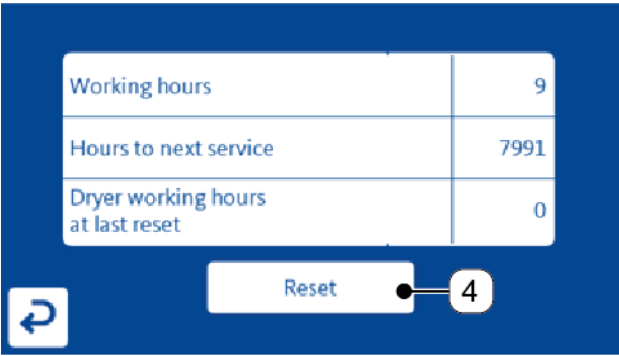
Final tasks	
1.	Follow the procedure in section "8 Commissioning" on page 59.
2.	Follow the procedure in section "10.2.1 Maintenance timer reset" on page 91.



10.2.1 Maintenance timer reset

Illustration	Description / explanation						
	<p>Maintenance timer reset</p> <ol style="list-style-type: none"> 1. With the device stopped or in normal running status, press the FUNCTIONS MENU button [1] to access the functions menu screen. 						
	<ol style="list-style-type: none"> 2. Press the OPERATING HOURS button [2] to access the information screen. 3. From each subsequent screen it is possible to return to the previous screen by pressing the BACK button [3]. 						
 <table border="1" data-bbox="252 1205 746 1397"> <tr> <td>Working hours</td> <td>9</td> </tr> <tr> <td>Hours to next service</td> <td>7991</td> </tr> <tr> <td>Dryer working hours at last reset</td> <td>0</td> </tr> </table>	Working hours	9	Hours to next service	7991	Dryer working hours at last reset	0	<ol style="list-style-type: none"> 4. Press the MAINTENANCE TIMER RESET button [4] to reset the maintenance timer. <p>This button is used by maintenance personnel only. To avoid incorrect operations, its function is protected by a security PIN.</p>
Working hours	9						
Hours to next service	7991						
Dryer working hours at last reset	0						
	<ol style="list-style-type: none"> 5. Confirm the operation by pressing the CONFIRM button [6] or abort the command by pressing EXIT [5]. 						

11. Adjustments

11.1 Warning notices

DANGER	Pressurised system
	<p>There is a danger of death or serious personal injury resulting from contact with fast or suddenly escaping fluids or bursting system parts.</p>
	<ul style="list-style-type: none"> • Set up a safety area around the working area during assembly, installation, maintenance and repair work. • Slowly pressurise the system.
DANGER	Electric voltage
	<p>There is a danger of death or serious injuries if electrified components are touched. Malfunction, device failure and material damage can occur.</p>
	<ul style="list-style-type: none"> • Set up a safety area around the working area during assembly, installation, maintenance and repair work.
WARNING	Refrigerant fluid
	<p>The incorrect handling of refrigerant fluid may result in serious injury. Malfunctions, device failure and environment damage can occur. Refer to the product type plate for the type and amount of refrigerant fluid in the product.</p>
	<ul style="list-style-type: none"> • Work on the product and accessories must be carried out exclusively by skilled technical personnel specialising in refrigeration engineering and customer service.

WARNING	Hot surfaces
	Contact with hot surfaces during work on the product and accessories can lead to burns, accidents and personal injury.
	<ul style="list-style-type: none"> • Pay attention to the hot surfaces during adjustment work.
WARNING	Insufficient qualification
	If personnel carrying out work on the product and accessories are not properly qualified, this may result in accidents, personal injury and damage to property and impair operations.
	<ul style="list-style-type: none"> • Work on the product and accessories must be carried out exclusively by skilled technical personnel specialising in customer service.
WARNING	Entry of moisture or foreign bodies
	Removing components or opening the product may allow water or foreign bodies to enter the product. Entry of water or foreign bodies can lead to accidents, personal injury, damage to property and impair operation.
	<ul style="list-style-type: none"> • Protect the product against water splashes or moisture. • Open the product or remove components in a dry place. • Do not insert any foreign bodies into product openings. • Keep contact surfaces and openings free from dirt and moisture.

11.2 Adjustment

Adjustment must be carried out while wearing the following protective equipment.

Prerequisites		
Tools	Material	Protective equipment
<ul style="list-style-type: none"> • No tool necessary 	<ul style="list-style-type: none"> • No material necessary 	

11.2.1 Adjustment of hot gas by-pass valve

NOTE	Schrader service valve
	Each time a pressure gauge is connected to the Schrader service valve, a part of refrigerant fluid is discharged in the environment.
	<ul style="list-style-type: none">• Connect the pressure gauge to the Schrader service valve if there is a significant refrigerant circuit malfunction.

INFORMATION	Hot gas by-pass valve factory setting
	The hot gas by-pass valve is adjusted by the manufacturer during the device testing phase and the adjusting screw is sealed with yellow sealant. If there is a refrigerant circuit malfunction, the by-pass valve can be recalibrated.

Preparatory tasks	
1.	The device is stopped.
2.	Inlet / outlet air valves must be closed. Compressed air must not flow into the heat exchanger.
3.	Remove service panels.
4.	A low pressure gauge must be connected to the Schrader service valve on the low pressure side of refrigerant circuit.
5.	A set of hex keys is available.

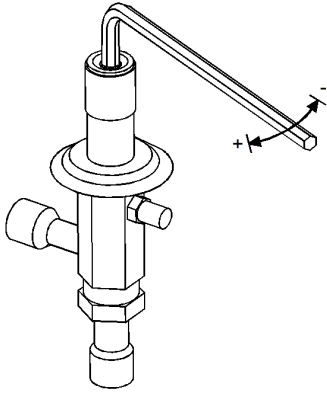
Adjustment	
Illustration	Description / explanation
	<ol style="list-style-type: none"> 1. Start the device and wait a few minutes. 2. Turn the adjustment screw clockwise to increase or counterclockwise to reduce the evaporation pressure. 3. Wait for the evaporation pressure to stabilise, until the set point value 2.3 bar(g), +0.1/-0 bar (33.4 psi(g) +1.5/-0 psi) is reached.

Final tasks	
1.	Disconnect the low pressure gauge from the refrigerant circuit.
2.	Reinstall the service panels.
3.	Slowly open the air inlet valve.
4.	Slowly open the air outlet valve.

11.2.2 Adjustment of cooling water regulating valve, water-cooled models

NOTE	Schrader service valve
	Each time a pressure gauge is connected to the Schrader service valve, a part of refrigerant fluid is discharged in the environment.
	<ul style="list-style-type: none"> Connect the pressure gauge to the Schrader service valve if there is a significant refrigerant circuit malfunction.

INFORMATION	Cooling water regulating valve factory setting
	The cooling water regulating valve is adjusted by the manufacturer during the testing phase with a setup that covers the majority of operating conditions. If there is a refrigerant circuit malfunction due to extreme operating conditions, the valve can be recalibrated.

Preparatory tasks	
1.	The device is stopped.
2.	Inlet / outlet air valves must be closed. Compressed air must not flow into the heat exchanger.
3.	Remove service panels.
4.	Cooling water supply must be available.
5.	A high pressure gauge must be connected to the Schrader service valve on the high pressure side of refrigerant circuit.

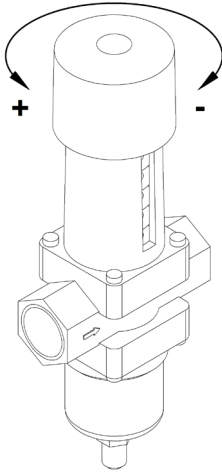
Adjustment	
Illustration	Description / explanation
	<ol style="list-style-type: none"> Start the device and wait a few minutes. Turn the adjustment knob clockwise to reduce or counterclockwise to increase the condensing pressure. Wait for the condensing pressure to stabilise, until the set point value 10 bar(g), +0,5/-0,5 bar (145.0 psi(g) +7.3/-7.3 psi) is reached.

Final tasks

1.	Disconnect the high pressure gauge from the refrigerant circuit.
2.	Reinstall the service panels.
3.	Slowly open the air inlet valve.
4.	Slowly open the air outlet valve.

12. Spare parts

12.1 Order information

The spare parts list for each device is printed on a sticker applied on the internal side of the device's rear panel. Each spare part is identified with its callout number referred to section "3.1 Product overview" on page 19 and its Material Number.

BEKO TECHNOLOGIES customer service requires the following data for an inquiry or order:

- Product name and installation size (see type plate)
- Serial number (see type plate)
- Material number and part designation
- Required quantity of parts to be delivered

The contact data for **BEKO TECHNOLOGIES** customer service are listed in section "1.1 Contact" on page 6.

12.2 Spare parts

INFORMATION	Callouts
	Callouts [#] mentioned below are included in section "3.1 Product overview" on page 19.



No.	Designation
[1]	Heat exchanger
[4]	High pressure switch HPS
[6]	Refrigerant compressor
[7]	Hot gas by-pass valve
[8]	Condenser
[9]	Cooling fan
[10]	Refrigerant fluid filter
[12]	Temperature probe BT1
[13]	Condensate drain service valve
[17.1]	Electronic Control Unit
[17.2]	User Interface
[18]	Water condenser
[19]	Water regulating valve
[21]	Condensate drain
[22]	ON-OFF switch
[37]	Pressure transducer BHP
[39]	Pressure transducer BLP

13. Decommissioning

The product must be decommissioned during longer periods of standstill, for example:

- Product or accessory maintenance.
- Longer standstill of the system due to planned work (e.g. conversion work, major repairs, system decommissioning).
- Product disassembly.

13.1 Warning notices

DANGER	Pressurised system
	<p>There is a danger of death or serious personal injury resulting from contact with fast or suddenly escaping fluids or bursting system parts.</p> <ul style="list-style-type: none"> • Set up a safety area around the working area before starting work.
DANGER	Electric voltage
	<p>There is a danger of death or serious injuries if electrified components are touched. Malfunction, device failure and material damage can occur.</p> <ul style="list-style-type: none"> • Set up a safety area around the working area before starting work.
WARNING	Insufficient qualification
	<p>If personnel carrying out work on the product and accessories are not properly qualified, this may result in accidents, personal injury and damage to property and impair operations.</p> <ul style="list-style-type: none"> • Work on the product and accessories must be carried out exclusively by skilled technical personnel specialising in customer service.

13.2 Decommissioning



Decommissioning must be carried out while wearing the following protective equipment.

Prerequisites		
Tools	Material	Protective equipment
<ul style="list-style-type: none"> No tool necessary 	<ul style="list-style-type: none"> No material necessary 	

Decommissioning	
1.	Slowly close the air inlet valve and secure it against unintentional opening.
2.	Slowly close the air outlet valve and secure it against unintentional opening.
3.	Wait a few minutes and then stop the product by pushing the START-STOP button on the User Interface for three seconds. Refer to section "9.3 Overview of User Interface after power ON" on page 63.
4.	Water-cooled models: interrupt the cooling water supply and secure it against unintentional opening.
5.	Turn off the power acting on the ON-OFF switch. Refer to section "3.1 Product overview" on page 19.
6.	Interrupt the mains and secure it against being accidentally switched on.
7.	Depressurise the product air circuit.
8.	Depressurise the product water circuit.

14. Disassembly

14.1 Warning notices

DANGER	Pressurised system
	<p>There is a danger of death or serious personal injury resulting from contact with fast or suddenly escaping fluids or bursting system parts.</p>
	<ul style="list-style-type: none"> • Set up a safety area around the working area before starting work. • Before starting work, depressurise the system and secure it against unintentional pressurisation.
DANGER	Electric voltage
	<p>There is a danger of death or serious injuries if electrified components are touched.</p>
	<ul style="list-style-type: none"> • Set up a safety area around the working area before starting work. • Before starting work, disconnect the product and accessories and prevent them from being switched back ON unintentionally.
WARNING	Refrigerant fluid
	<p>The incorrect handling of refrigerant fluid may result in serious injury and environment damage. Refer to the product type plate for the type and amount of refrigerant fluid in the product.</p>
	<ul style="list-style-type: none"> • Work on the product and accessories must be carried out exclusively by skilled technical personnel specialising in refrigeration engineering and customer service. • Pick up the refrigerant fluid under applicable local laws and requirements.

WARNING	Insufficient qualification
	If personnel carrying out work on the product and accessories are not properly qualified, this may result in accidents, personal injury and damage to property.
	<ul style="list-style-type: none"> • Work on the product and accessories must be carried out exclusively by skilled technical personnel specialising in refrigeration engineering and customer service.

CAUTION	Condensate
	Contact with condensate containing substances which endanger health and the environment can pose a health hazard, causing irritation or damage to the eyes, skin and mucous membranes.
	<ul style="list-style-type: none"> • Use suitable protective equipment when handling condensate. • Pick up and dispose of any leaking or spilled condensate under applicable regional laws and requirements.

14.2 Disassembly

Disassembly must be carried out while wearing the following protective equipment and after the preparatory tasks have been completed.

Prerequisites		
Tools	Material	Protective equipment
<ul style="list-style-type: none"> No tool necessary 	<ul style="list-style-type: none"> No material necessary 	

Preparatory tasks	
1.	The procedure on section "13 Decommissioning" on page 100 must be carried out.
2.	Have the necessary tools ready.

Disassembly	
1.	Disconnect the power cable from the protective contact socket / terminal box.
2.	Uninstall collision protection, if installed.
3.	Disconnect the condensate drain hose from the drain collection line.
4.	Water-cooled models: disconnect the threaded connection from the cooling water line.
5.	Disconnect the threaded connection from the compressed air line.
6.	Remove fixing bolts, if the product was fixed on the floor.
7.	Remove the service panels on the product.
8.	Remove disassembled parts and accessories from the installation location.
9.	Remove the refrigerant fluid from the refrigerant circuit.
10.	Clean the installation area from any fluid or oil leakage occurred during disassembly.

15. Disposal

15.1 Warning notices

NOTE	Incorrect disposal
	Incorrect disposal of components, parts, operating and auxiliary materials, refrigerant fluid and cleaning media can cause environmental damage.
	<ul style="list-style-type: none"> • Dispose of components, parts, operating and auxiliary materials, refrigerant fluid and cleaning media properly and under national and local applicable regulations and standards. • Do not discharge the refrigerant into atmosphere. • Dispose of electrical and electronic components through a specialist waste disposal company. • When in doubt, consult a local disposal company before disposal.

NOTE	Incorrect storage
	Incorrect storage of components, parts, operating and auxiliary materials, refrigerant fluid and cleaning media can cause environmental damage.
	<ul style="list-style-type: none"> • Store components, parts, operating and auxiliary materials, refrigerant fluid and cleaning media properly and under national and local applicable regulations and standards.

INFORMATION	Disposal of electrical and electronic equipment
	<p>Electrical and electronic equipment (EEE) contains materials, components and substances which can be dangerous and harmful for human health and the environment if the waste from electrical and electronic equipment (WEEE) is not disposed of properly.</p> <p>Electrical and electronic equipment is marked by a crossed-out rubbish bin. A crossed-out rubbish bin symbolises that electrical and electronic equipment must be collected separately and must not be disposed of with unsorted domestic waste.</p> <p>For additional information regarding local applicable laws and regulations concerning recycling electrical and electronic products, contact your local disposal companies or the relevant municipal authority.</p>

15.2 Disposal of materials and components

Disposal must be carried out while wearing the following protective equipment and after the preparatory tasks have been completed.



Prerequisites		
Tools	Material	Protective equipment
<ul style="list-style-type: none"> No tool necessary 	<ul style="list-style-type: none"> No material necessary 	

Preparatory tasks	
1.	The procedure on section "14 Disassembly" on page 102 must be carried out.

Operating / auxiliary material	Material	EU waste code
Adsorption and filter materials, cleaning wipes and protective clothing – contaminated by oils or other hazardous substances	-	15 02 02
Adsorption and filter materials, cleaning wipes and protective clothing – except those classified under 15 02 02	-	15 02 03
Packaging	Paper / cardboard	15 01 01
	Plastic	15 01 02
	Wood	15 01 03

Component	Material	EU waste code
Device (with or without refrigerant fluid)	-	16 02 11
Refrigerant fluid	-	14 06 01
Refrigerant compressor (sealed, with oil included)	-	16 02 15
Refrigerant fluid filter (sealed)	-	16 02 15
Refrigerant circuit tubes	Copper	17 04 01
Condenser (tubes)		
Condenser (frame)	Iron / carbon steel	17 04 05
Fan grid		
Hot gas by-pass valve		
Panels, mounting frame, supports, screws		
Heat exchanger	Aluminium	17 04 02
Condenser (fins)		
Fan blade		
Complete cooling fan	Electric / electronic components with their plastic parts	16 02 16
Fan motor (with capacitor removed)		
Temperature probes		
Pressure transducers		
Pressure switches		
ON-OFF switch		
Electronic Control Unit / User Interface		
Condensate drain		
Other electric / electronic components		
Capacitor (removed from cooling fan motor)	-	16 02 15
Electrical wires	PVC / copper	17 04 11
Insulating material	Elastomeric foam	17 06 04
Other plastic parts	Plastic	15 01 02
Condensate drain hose	Contaminated plastic / rubber	16 01 21

16. Troubleshooting

INFORMATION	Applicable documents
	The following applicable documents are necessary and available: <ul style="list-style-type: none">• BEKOMAT® Installation and operating manual.• Wiring diagrams.
INFORMATION	Technical support
	This section contains solutions to the most probable malfunctions/faults. It is impossible to predict all device malfunctions and failures. If there are any malfunctions / faults which are not described here, malfunctions which cannot be acknowledged / eliminated or other related questions, contact BEKO TECHNOLOGIES customer service. Refer to section "1.1 Contact" on page 6.

16.1 Warnings and alarms

16.1.1 Clearing a WARNING

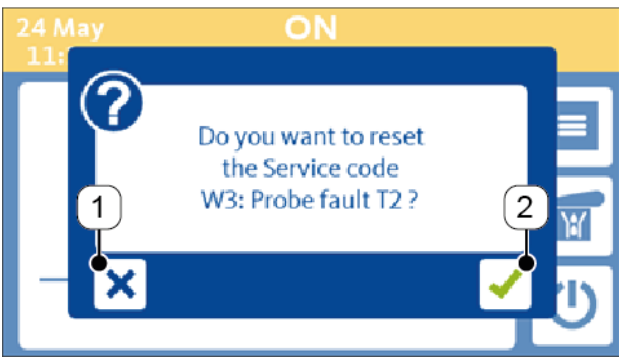
Illustration	Description / explanation
	<ol style="list-style-type: none"> 1. Refer to section "9.4.5 WARNING status" on page 71. 2. Fix the cause which has triggered the WARNING. 3. The User Interface notification area stops flashing and turns permanently orange. 4. Touch the notification area.
	<ol style="list-style-type: none"> 5. Confirm the operation by pressing the CONFIRM button [2] or abort the command by pressing EXIT [1].

WARNING code – Text	Cause	Action
W1 – Low Dew Point Trigger: T1 < -1.0 °C Reset: T1 ≥ 0.0 °C Delay: 3 minutes	Probe BT1, the dew point temperature is too low.	Refer to section "16.2 Specific malfunctions" on page 117, "Probe BT1, dew point temperature too low".
W2 – High Dew Point Trigger: T1 > had value ResehadHdA value - 1 K Delay: Hdd value	The value of parameter HdA is too low.	Increase the value of parameter HdA .
	Probe BT1, the dew point temperature is too high.	Refer to section "16.2 Specific malfunctions" on page 117, "Probe BT1, dew point temperature too high".
W3 – Probe Fault T2 Trigger: BT2 fault Reset: BT2 reset Delay: none	The electrical wiring between Probe BT2 and the Electronic Control Unit is interrupted.	Restore the electrical wiring.
	Probe BT2, defective or faulty.	Replace the probe.
W4 – Probe Fault T3 Trigger: BT3 fault Reset: BT3 reset Delay: none	The electrical wiring between Probe BT3 and the Electronic Control Unit is interrupted.	Restore the electrical wiring.
	Probe BT3, defective or faulty.	Replace the probe.
W5 – Drainer Trigger: DI5 open Reset: DI5 closed Delay: 20 minutes	The condensate drain is defective or faulty	Consult the BEKOMAT ® Installation and operating manual.
	The electrical wiring between the condensate drain and Electronic Control Unit is interrupted.	Restore the electrical wiring.
	Compressed air line is depressurised.	Pressurise the compressed air line.
W5 Dn nn Drainer, specific faults	Condensate drain specific malfunction.	Consult BEKO TECHNOLOGIES
W6 – Programmed Service Trigger: SrV value Reset: timer reset Delay: none	The maintenance time is expired.	Refer to section "10.2 Maintenance" on page 90.
W7 – High Discharge Temp. Trigger: T4 > 100.0 °C Reset: T4 < 95.0 °C Delay: 60 seconds	Probe BT4, the temperature on discharge side of refrigerant compressor is too high.	Refer to section "16.2 Specific malfunctions" on page 117, "Probe BT4, compressor discharge temperature too high".

WARNING code – Text	Cause	Action
<p>W9 – Low Condensing Pressure Trigger: variable Reset: variable Delay: 600 seconds</p>	<p>Transducer BHP, the condensing pressure of the refrigerant fluid is too low.</p>	<p>Refer to section "16.2 Specific malfunctions" on page 117, "Transducer BHP, condensing pressure of refrigerant fluid too low".</p>
<p>W10 – High Condensing Pressure Trigger: variable Reset: variable Delay: 600 seconds</p>	<p>Transducer BHP, the condensing pressure of the refrigerant fluid is too high.</p>	<p>Refer to section "16.2 Specific malfunctions" on page 117, "Transducer BHP, condensing pressure of refrigerant fluid too high".</p>
<p>W11 – Low Ambient Temp. Trigger: $T5 < 0.0\text{ °C}$ Reset: $T5 \geq 1.0\text{ °C}$ Delay: 5 minutes</p>	<p>Probe BT5, the ambient temperature is too low.</p>	<p>Restore the nominal operating conditions.</p>
<p>W12 – High Ambient Temp. Trigger: $T5 > 45.0\text{ °C}$ Reset: $T5 \leq 42.0\text{ °C}$ Delay: 5 minutes</p>	<p>Probe BT5, the ambient temperature is too high.</p>	<p>Restore the nominal operating conditions.</p>
<p>W13 – Probe Fault T5 Trigger: BT5 fault Reset: BT5 reset Delay: none</p>	<p>The electrical wiring between Probe BT5 and the Electronic Control Unit is interrupted.</p>	<p>Restore the electrical wiring.</p>
	<p>Probe BT5, defective or faulty.</p>	<p>Replace the probe.</p>
<p>W14 – Low Inlet Temperature Trigger: $T2 < 10.0\text{ °C}$ Reset: $T2 \geq 11.0\text{ °C}$ Delay: 5 minutes</p>	<p>Probe BT2, the inlet air temperature is too low.</p>	<p>Restore the nominal operating conditions.</p>
<p>W15 – High Inlet Temperature Trigger: $T2 > 70.0\text{ °C}$ Reset: $T2 \leq 65.0\text{ °C}$ Delay: 5 minutes</p>	<p>Probe BT2, the inlet air temperature is too high.</p>	<p>Restore the nominal operating conditions.</p>

16.1.2 Clearing an ALARM



Illustration	Description / explanation
	<ol style="list-style-type: none"> 1. Refer to section "9.4.6 ALARM status" on page 73. 2. Fix the cause which has triggered the ALARM. 3. The User Interface notification area stops flashing and turns permanently red. 4. Touch the notification area to access the list of all stored ALARMS.
	<ol style="list-style-type: none"> 5. Touch the red area with the ALARM to be cleared.
	<ol style="list-style-type: none"> 6. Confirm the operation by pressing the CONFIRM button [2] or abort the command by pressing EXIT [1].

Illustration	Description / explanation																
 <p>The screenshot shows a table with the following data:</p> <table border="1" style="width: 100%; border-collapse: collapse;"> <thead> <tr> <th style="background-color: #0056b3; color: white;">Code</th> <th style="background-color: #0056b3; color: white;">Start</th> <th style="background-color: #0056b3; color: white;">End</th> <th style="background-color: #0056b3; color: white;">Description</th> </tr> </thead> <tbody> <tr> <td>A 14</td> <td>18/05 14:15</td> <td>18/05 14:33</td> <td>Reversed Phases</td> </tr> <tr> <td>A 2</td> <td>18/05 14:12</td> <td>18/05 14:12</td> <td>Low Pressure switch</td> </tr> <tr> <td>A 1</td> <td>18/05 13:55</td> <td>18/05 13:55</td> <td>High Pressure switch</td> </tr> </tbody> </table> <p>Below the table, a callout box with the number '3' points to a button with a USB stick icon and the text 'DATA RECORDING'.</p>	Code	Start	End	Description	A 14	18/05 14:15	18/05 14:33	Reversed Phases	A 2	18/05 14:12	18/05 14:12	Low Pressure switch	A 1	18/05 13:55	18/05 13:55	High Pressure switch	<p>ALARM history download</p> <p>To download the ALARM history, a USB memory stick must be installed by maintenance personnel. Refer to section "7.2.7 USB memory stick for data log storage" on page 58.</p> <p>7. Press the DATA RECORDING button [3] to download the entire ALARM history.</p>
Code	Start	End	Description														
A 14	18/05 14:15	18/05 14:33	Reversed Phases														
A 2	18/05 14:12	18/05 14:12	Low Pressure switch														
A 1	18/05 13:55	18/05 13:55	High Pressure switch														
 <p>The screenshot shows a dialog box with a question mark icon and the text "Do you want to save the alarm log?". At the bottom left, there is a button with a blue 'X' icon, labeled with callout '1'. At the bottom right, there is a button with a green checkmark icon, labeled with callout '2'.</p>	<p>8. Confirm the download by pressing the CONFIRM button [2] or abort the command by pressing EXIT [1].</p> <p>9. Once the downloading is finished, remove the USB memory stick for further analysis.</p> <p>The USB memory stick must be removed by the maintenance personnel.</p>																

ALARM code - Text	Cause	Action
<p>A1 – High Pressure Switch Trigger: DI HPS open Reset: DI HPS closed Delay: none</p>	<p>High Pressure Safety Switch (HPS), the pressure of the refrigerant fluid has reached the safety limit.</p>	<p>Refer to section "16.2 Specific malfunctions" on page 117, "High Pressure Safety Switch (HPS) has triggered".</p>
<p>A2 – Low Pressure Switch Trigger: LP < 0.7 bar(g) Reset: LP ≥ 1.7 bar(g) Delay: (*1)</p>	<p>Transducer BLP, the pressure of the refrigerant fluid has reached the minimum value allowed. There is a refrigerant circuit leak.</p>	<p>Repair the refrigerant circuit.</p>
<p>A3 – Low Evaporating Pressure Trigger: LP < 2.0 bar(g) Reset: LP ≥ 2.3 bar(g) Delay: 300 seconds</p>	<p>Transducer BLP, the evaporating pressure of the refrigerant fluid is too low.</p>	<p>Refer to section "16.2 Specific malfunctions" on page 117, "Transducer BLP, evaporating pressure of refrigerant fluid too low".</p>
<p>A4 – High Discharge Temp. Trigger: T4 > 110.0 °C Reset: T4 ≤ 100.0°C Delay: 60 seconds</p>	<p>Probe BT4, the temperature of the refrigerant fluid has reached the safety limit.</p>	<p>Refer to section "16.2 Specific malfunctions" on page 117, "Probe BT4, compressor discharge temperature too high".</p>
<p>A5 – Compressor Protection Trigger: DI4 open Reset: DI4 closed Delay: none</p>	<p>The internal heat protection of refrigerant compressor has triggered.</p>	<p>Wait 30 minutes to cool down the motor then check the refrigerant compressor operation.</p>
	<p>Circuit breaker QC1 has triggered.</p>	<p>Restore circuit breaker QC1 then check the refrigerant compressor operation.</p>
<p>A6 - ICE Trigger: T1 < -3.0 °C Reset: T1 ≥ 0.0 °C Delay: 60 seconds</p>	<p>Probe BT1, the heat exchanger temperature is under 0°C.</p>	<p>Refer to section "16.2 Specific malfunctions" on page 117, "Probe BT1, dew point temperature too low".</p>

ALARM code - Text	Cause	Action
A7 – Probe Fault LP Trigger: BLP fault Reset: BLP reset Delay: none	Transducer BLP, defective or faulty.	Replace the transducer.
	The electrical wiring between transducer BLP and the Electronic Control Unit is interrupted.	Restore the electrical wiring.
A8 – Probe Fault HP Trigger: BHP fault Reset: BHP reset Delay: none	Transducer BHP, defective or faulty.	Replace the transducer.
	The electrical wiring between transducer BHP and the Electronic Control Unit is interrupted.	Restore the electrical wiring.
A9 – Probe Fault T1 Trigger: BT1 fault Reset: BT1 reset Delay: none	Probe BT1, defective or faulty.	Replace the probe.
	The electrical wiring between probe BT1 and the Electronic Control Unit is interrupted.	Restore the electrical wiring.
A10 – Probe Fault T4 Trigger: BT4 fault Reset: BT4 reset Delay: none	Probe BT4, defective or faulty.	Replace the probe.
	The electrical wiring between probe BT4 and the Electronic Control Unit is interrupted.	Restore the electrical wiring.

(*1) zero seconds at device start-up, two seconds during normal operation

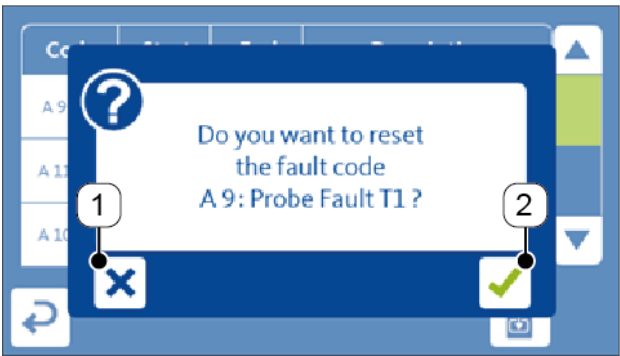
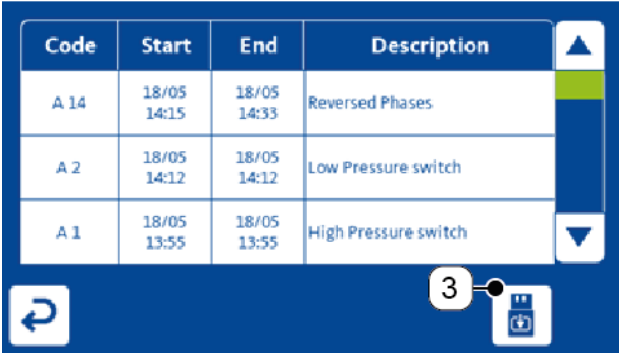
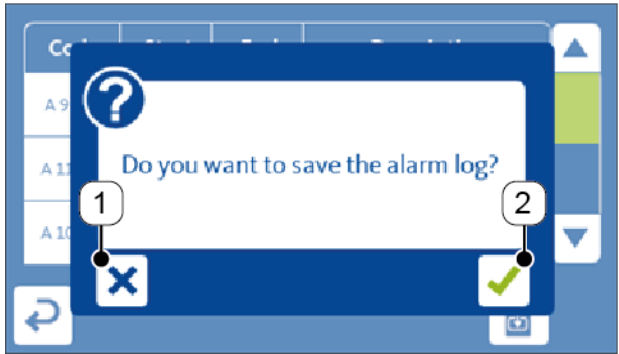
ALARM code – Text	Cause	Action
A11 – Low Differential Pressure Trigger: $\Delta p < 2.5 \text{ bar(g)}$ Reset: $\Delta p \geq 2.5 \text{ bar(g)}$ Delay: (*2)	Transducers BHP and BLP, low differential pressure between HP and LP values.	Refer to section "16.2 Specific malfunctions" on page 117, "Transducers BHP and BLP, low differential pressure between HP and LP values".
A12 – High Evaporating Pressure Trigger: $LP > 4.8 \text{ bar(g)}$ Reset: $LP \leq 4.8 \text{ bar(g)}$ Delay: (*3)	Transducer BLP, evaporating pressure of the refrigerant fluid is too high.	Refer to section "16.2 Specific malfunctions" on page 117, "Transducer BLP, evaporating pressure of refrigerant fluid too high".
A13 – Low Condensing Pressure Trigger: variable Reset: variable Delay: (*3)	Transducer BHP, the condensing pressure of the refrigerant fluid is too low.	Refer to section "16.2 Specific malfunctions" on page 117, "Transducer BHP, condensing pressure of refrigerant fluid too low".
A14 – Reversed Phases Trigger: DI7 open Reset: DI7 closed Delay: (*4)	Relay RPP, power phases L1, L2, L3 are connected to the device with the incorrect phase sequence.	Restore the correct phase sequence
	Missing power phase.	Connect the missing phase
A19 - Fan Trigger: DI3 open Reset: DI3 closed Delay: none	The internal heat protection of cooling fan has triggered.	Wait 30 minutes to cool down the motor then check the cooling fan operation.
	Circuit breaker QV1 has triggered.	Restore circuit breaker QV1 then check the cooling fan operation, models RA 1490 / 3000
A E 1001 – Communication lost Trigger: cable HMI disconnected Reset: cable HMI connected Delay: 5 seconds	Communication broken between User Interface and the Electronic Control Unit	Check the integrity of HMI connection cable

(*2) 15 minutes at device start-up, 60 seconds during normal operation

(*3) 15 minutes at device start-up, 600 seconds during normal operation

(*4) zero seconds at device start-up, two seconds during normal operation

16.2 Specific malfunctions

Specific malfunction	Cause	Action
Probe BT1, dew point temperature too high.	Probe BT1 does not detect the temperature correctly.	Check / place the probe back in its correct position.
	The refrigerant compressor stopped.	See "The refrigerant compressor stopped" specific malfunction.
	The ambient temperature is too high or ventilation is insufficient.	Restore the nominal operating conditions.
	The inlet compressed air temperature is too high.	
	The inlet compressed air pressure is too low.	
	The inlet compressed air flow rate is higher than the device nominal flow rate.	
	The condenser is dirty.	Clean the condenser.
	The cooling fan stopped.	See "The cooling fan stopped" specific malfunction.
	The device does not drain condensate.	See "The device does not drain condensate" specific malfunction.
	The hot gas by-pass valve is out of calibration, models from RA 1080 to RA 1900	Refer to section "11.2.1 Adjustment of hot gas by-pass valve" on page 94.
	There is a refrigerant circuit leak.	Repair the refrigerant circuit.
	The cooling water temperature is too high, water-cooled models.	Restore the nominal operating conditions.
	The cooling water flow rate is too low, water-cooled models.	
Probe BT1, dew point temperature too low.	The ambient temperature is too low or the device is installed in a windy area.	Restore the nominal operating conditions.
	The cooling fan is running continuously.	Replace the Electronic Control Unit.
	The hot gas by-pass valve is out of calibration, models from RA 1080 to RA 1900	Refer to section "11.2.1 Adjustment of hot gas by-pass valve" on page 94.

Specific malfunction	Cause	Action
Probe BT4, compressor discharge temperature too high.	Probe BT4 does not detect the temperature correctly.	Check / place the probe back in its correct position.
	Excessive thermal load.	Restore the nominal operating conditions.
	The inlet compressed air temperature is too high.	
	The inlet compressed air flow rate is higher than the device nominal flow rate.	
	The ambient temperature is too high or ventilation is insufficient.	Clean the condenser.
	The condenser is dirty.	See "The cooling fan stopped" specific malfunction.
	The cooling fan stopped.	Refer to section "11.2.1 Adjustment of hot gas by-pass valve" on page 94.
	The hot gas by-pass valve is out of calibration, models from RA 1080 to RA 1900	Restore the nominal operating conditions.
	The cooling water temperature is too low, water-cooled models.	Refer to section "11.2.2 Adjustment of cooling water regulating valve, water-cooled models" on page 96.
	The cooling water regulating valve is out of calibration, water-cooled models.	
	There is a refrigerant circuit leak.	Repair the refrigerant circuit.
Transducer BLP, refrigerant fluid evaporating pressure too high.	Excessive thermal load.	Restore the nominal operating conditions.
	The inlet compressed air temperature is too high.	
	The ambient temperature is too high or ventilation is insufficient.	
	The condenser is dirty.	Clean the condenser.
	The cooling fan stopped.	See "The cooling fan stopped" specific malfunction.
	The hot gas by-pass valve is out of calibration, models from RA 1080 to RA 1900	Refer to section "11.2.1 Adjustment of hot gas by-pass valve" on page 94.
	The cooling water regulating valve is out of calibration, water-cooled models.	Refer to section "11.2.2 Adjustment of cooling water regulating valve, water-cooled models" on page 96.
	Transducer BLP is defective.	Replace the transducer.
The refrigerant compressor stopped.	See "The refrigerant compressor stopped" specific malfunction.	

Specific malfunction	Cause	Action
Transducer BHP, refrigerant fluid condensing pressure too low.	The ambient temperature is too low or the device is installed in a windy area.	Restore the nominal operating conditions.
	The cooling water temperature is too low, water-cooled models.	
	The cooling water regulating valve is out of calibration, water-cooled models.	Refer to section "11.2.2 Adjustment of cooling water regulating valve, water-cooled models" on page 96.
	There is a refrigerant circuit leak.	Repair the refrigerant circuit.
	Transducer BHP is defective.	Replace the transducer.
	The refrigerant compressor stopped.	See "The refrigerant compressor stopped" specific malfunction.
Transducer BLP, refrigerant fluid evaporating pressure too low.	There is a refrigerant circuit leak.	Repair the refrigerant circuit.
	The hot gas by-pass valve is out of calibration, models from RA 1080 to RA 1900	Refer to section "11.2.1 Adjustment of hot gas by-pass valve" on page 94.
	Transducer BLP is defective.	Replace the transducer.
	The cooling fan is running continuously.	Replace the Electronic Control Unit.
Transducer BHP, refrigerant fluid condensing pressure too high.	The inlet compressed air temperature is too high.	Restore the nominal operating conditions.
	The ambient temperature is too high or ventilation is insufficient.	
	The inlet compressed air flow rate is higher than the device nominal flow rate.	
	The condenser is dirty.	Clean the condenser.
	The cooling fan stopped.	See "The cooling fan stopped" specific malfunction.
	The cooling water temperature is too high, water-cooled models.	Restore the nominal operating conditions.
	The cooling water flow rate is too low, water-cooled models.	
	The cooling water regulating valve is out of calibration, water-cooled models.	Refer to section "0 Adjustment of cooling water regulating valve, water-cooled models" on page 96.
Transducer BHP is defective.	Replace the transducer.	

Specific malfunction	Cause	Action
Transducers BHP and BLP, low differential pressure between HP and LP values.	The ambient temperature is too low or the device is installed in a windy area.	Restore the nominal operating conditions.
	The cooling water temperature is too low, water-cooled models.	
	The cooling water regulating valve is out of calibration, water-cooled models.	Refer to section "0 Adjustment of cooling water regulating valve, water-cooled models" on page 96.
	The hot gas by-pass valve is out of calibration, models from RA 1080 to RA 1900	Refer to section "11.2.1 Adjustment of hot gas by-pass valve" on page 94.
	There is a refrigerant circuit leak.	Repair the refrigerant circuit.
	Transducer BLP is defective.	Replace the transducer.
	Transducer BHP is defective.	
The refrigerant compressor stopped.	See "The refrigerant compressor stopped" specific malfunction.	
Safety pressure switch HPS has triggered.	The inlet compressed air temperature is too high.	Restore the nominal operating conditions, then press the reset button on the pressure switch.
	The inlet compressed air flow rate is higher than the device nominal flow rate.	
	The ambient temperature is too high or ventilation is insufficient.	
	The condenser is dirty.	Clean the condenser, then press the reset button on the pressure switch.
	The cooling fan stopped.	See "The cooling fan stopped" specific malfunction, then press the reset button on the pressure switch.
	The cooling water temperature is too high, water-cooled models.	Restore the nominal operating conditions, then press the reset button on the pressure switch.
	The cooling water flow rate is too low, water-cooled models.	
Pressure switch HPS is defective.	Replace the pressure switch.	
The refrigerant compressor stopped, without any warning / alarm on the User Interface.	The electrical wiring is interrupted.	Restore the electrical wiring.
	The compressor is faulty.	Replace the compressor.

Specific malfunction	Cause	Action
The cooling fan stopped, without any warning / alarm on the User Interface.	There is a refrigerant circuit leak.	Repair the refrigerant circuit.
	The electrical wiring is interrupted.	Restore the electrical wiring.
	Transducer BHP is defective.	Replace the transducer.
	The motor is faulty.	Replace the motor.
The device does not drain condensate.	The compressed air pressure is too low.	Restore the nominal operating conditions.
	The condensate service valve is closed.	Open the valve.
	Condensate is frozen.	See "Probe BT1, dew point temperature too low" specific malfunction.
	The BEKOMAT ® condensate drain does not work properly.	Consult BEKOMAT ® Installation and operating manual.
The device continuously drains condensate.	The BEKOMAT ® condensate drain does not work properly.	Consult BEKOMAT ® Installation and operating manual.
Excessive air pressure drop.	Condensate is frozen.	See "Probe BT1, dew point temperature too low" specific malfunction.
	The device does not drain condensate.	See "The device does not drain the condensate" specific malfunction.
	The heat exchanger is clogged.	Check and clean the heat exchanger.

17. Notes

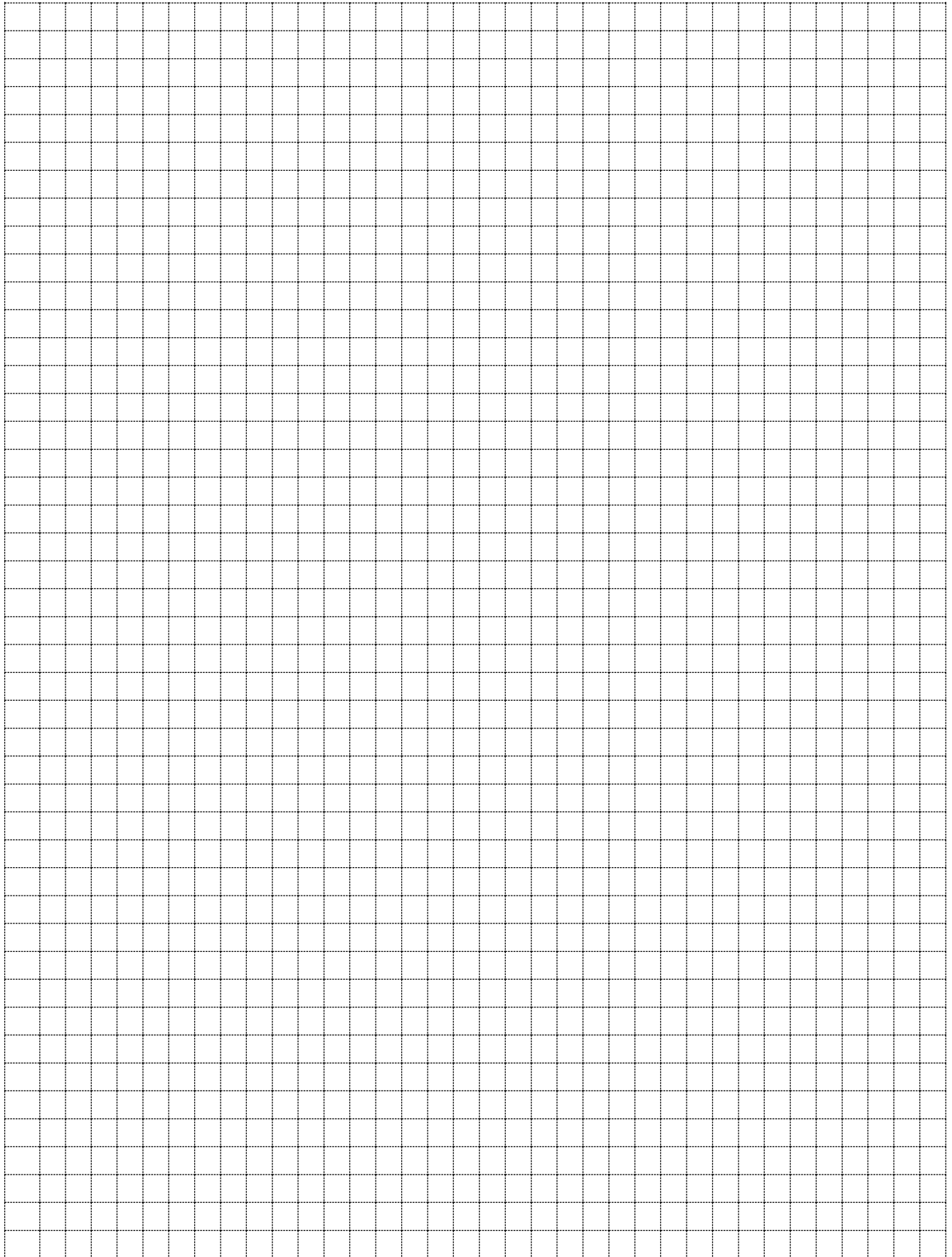

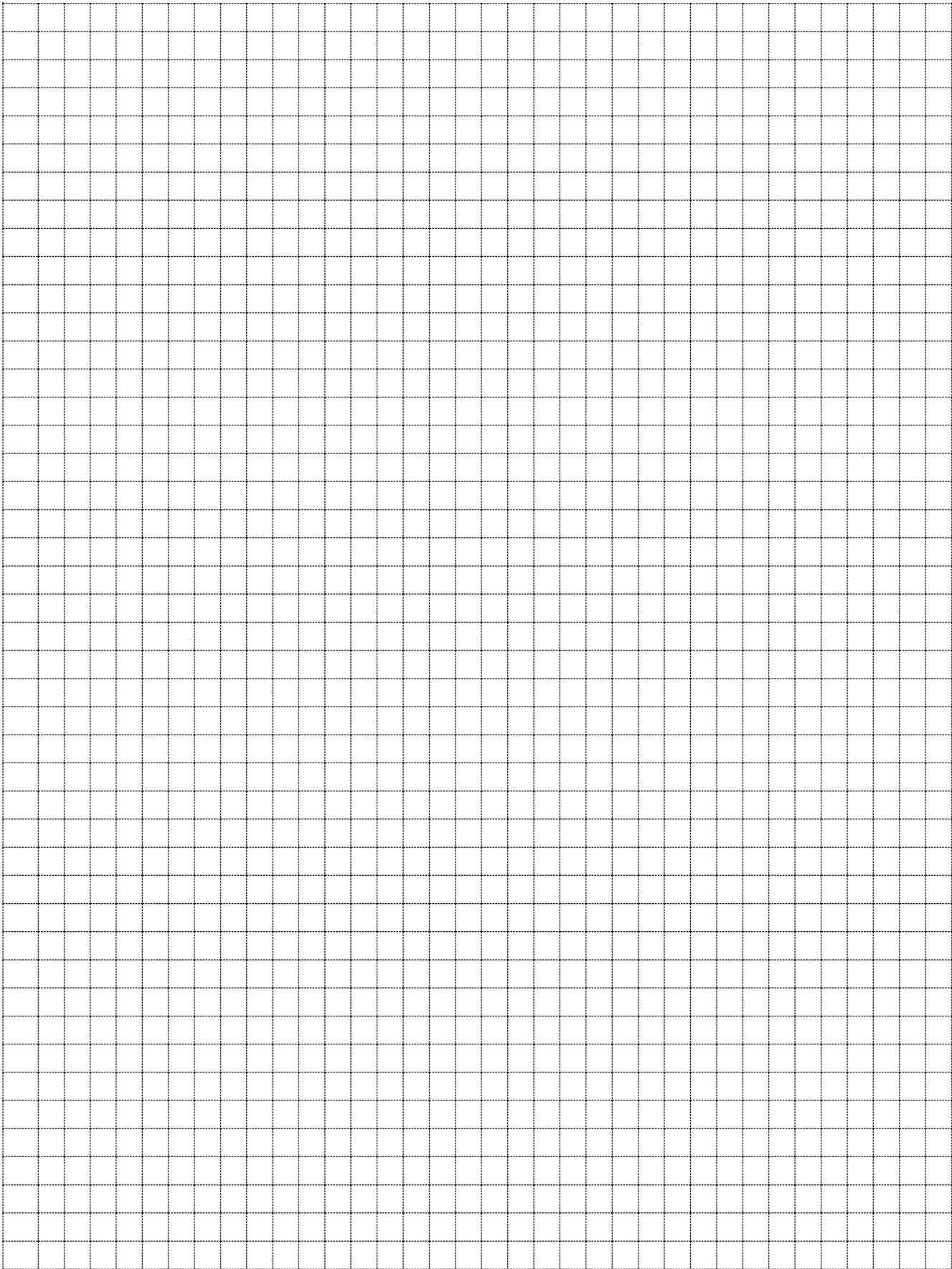

BEKO TECHNOLOGIES GmbH

Im Taubental 7
D - 41468 Neuss
Tel. +49 2131 988 0
Fax +49 2131 988 900
info@beko-technologies.com
service-eu@beko-technologies.com

DE

BEKO TECHNOLOGIES LTD.

Unit 11-12 Moons Park
Burnt Meadow Road
North Moons Moat
Redditch, Worcs, B98 9PA
Tel. +44 1527 575 778
info@beko-technologies.co.uk

GB

BEKO TECHNOLOGIES S.à.r.l.

Zone Industrielle
1 Rue des Frères Rémy
F - 57200 Sarreguemines
Tél. +33 387 283 800
info@beko-technologies.fr
service@beko-technologies.fr

FR

BEKO TECHNOLOGIES B.V.

Veenen 12
NL - 4703 RB Roosendaal
Tel. +31 165 320 300
benelux@beko-technologies.com
service-bnl@beko-technologies.com

NL

**BEKO TECHNOLOGIES
(Shanghai) Co. Ltd.**

Rm.715 Building C, VANTONE Center
No.333 Suhong Rd.Minhang District
201106 Shanghai
Tel. +86 (21) 50815885
info.cn@beko-technologies.cn
service1@beko.cn

CN

BEKO TECHNOLOGIES s.r.o.

Na Pankraci 58
CZ - 140 00 Praha 4
Tel. +420 24 14 14 717 /
+420 24 14 09 333
info@beko-technologies.cz

CZ

BEKO Tecnológica España S.L.

Torruella i Urpina 37-42, nave 6
E - 08758 Cervelló
Tel. +34 93 632 76 68
Mobil +34 610 780 639
info.es@beko-technologies.es

ES

BEKO TECHNOLOGIES LIMITED

Room 2608B, Skyline Tower,
No. 39 Wang Kwong Road
Kwloon Bay Kwloon, Hong Kong
Tel. +852 2321 0192
Raymond.Low@beko-technologies.com

HK

BEKO TECHNOLOGIES INDIA Pvt. Ltd.

Plot No.43/1 CIEEP Gandhi Nagar
Balanagar Hyderabad
IN - 500 037
Tel. +91 40 23080275 /
+91 40 23081107
Madhusudan.Masur@bekoindia.com
service@bekoindia.com

IN

BEKO TECHNOLOGIES S.r.l.

Via Peano 86/88
I - 10040 Leini (TO)
Tel. +39 011 4500 576
Fax +39 0114 500 578
info.it@beko-technologies.com
service.it@beko-technologies.com

IT

BEKO TECHNOLOGIES K.K.

KEIHIN THINK Building 8 Floor
1-1 Minamiwatarida-machi
Kawasaki-ku, Kawasaki-shi
JP - 210-0855
Tel. +81 44 328 76 01
info@beko-technologies.jp

JP

BEKO TECHNOLOGIES Sp. z o.o.

ul. Pańska 73
PL - 00-834 Warszawa
Tel. +48 22 314 75 40
info.pl@beko-technologies.pl

PL

BEKO TECHNOLOGIES S. de R.L. de C.

BEKO Technologies, S de R.L. de C.V.
Blvd. Vito Alessio Robles 4602 Bodega 10
Zona Industrial
Saltillo, Coahuila, 25107
Mexico
Tel. +52(844) 218-1979
informacion@beko-technologies.com

MX

BEKO TECHNOLOGIES CORP.

900 Great Southwest Pkwy SW
US - Atlanta, GA 30336
Tel. +1 404 924-6900
Fax +1 (404) 629-6666
beko@bekousa.com

US

