

EN - English



Instructions for installation and operation

Compressed-air refrigeration dryer **DRYPOINT® RA 3-160**

Dear customer,

Thank you for deciding in favour of the DRYPOINT® RA 3-160 compressed-air refrigeration dryer. Please read these installation and operating instructions carefully before mounting and starting up the DRYPOINT® RA 3-160, and follow our directions. Perfect functioning of the DRYPOINT® RA 3-160 and thus reliable compressed-air drying can only be guaranteed when the provisions and notes stipulated here are strictly adhered to.

Headquarters:

Deutschland / Germany

BEKO TECHNOLOGIES GMBH
Im Taubental 7
D-41468 Neuss
Phone: +49 (0)2131 988 0
beko@beko.de

中华人民共和国 / China

BEKO TECHNOLOGIES (Shanghai) Co.
Ltd.
Rm.606 Tomson Commercial Building
710 Dongfang Rd.
Pudong Shanghai China
P.C. 200122
Phone: +86 21 508 158 85
beko@beko.cn

France

BEKO TECHNOLOGIES S.a.r.l.
Zone Industrielle
1 Rue des Frères Remy
F- 57200 Sarreguemines
Phone: +33 387 283 800
beko@wanadoo.fr

India

BEKO COMPRESSED AIR
TECHNOLOGIES Pvt. Ltd.
Plot No.43/1, CIEEP, Gandhi Nagar,
Balanagar, Hyderabad - 500 037, INDIA
Phone: +91 40 23080275
eric.purushotham@bekoindia.com

Italia / Italy

BEKO TECHNOLOGIES S.r.l
Via America 14
I - 10071 Borgaro Torinese (TO)
Phone: +39 0114 500 576
info.it@beko.de

日本 / Japan

BEKO TECHNOLOGIES K.K
KEIHIN THINK 8 Floor
1-1 Minamiatarida-machi
Kawasaki-ku, Kawasaki-shi
JP-210-0855
Phone: +81 44 328 76 01
info@beko-technologies.co.jp

Benelux

BEKO TECHNOLOGIES B.V.
Vaartveld 25
NL - 4704 SE Roosendaal
Phone: +31 165 320 300
info@beko.nl

Polska / Poland

BEKO TECHNOLOGIES Sp. z o.o.
ul. Chłapowskiego 47
PL-02-787 Warszawa
Phone: +48 (0)22 855 30 95
info.pl@beko.de

Scandinavia

BEKO TECHNOLOGIES AS
P.O.Box 12 N-1393 Vollen
Leangbukta 31
N-1392 VETTRE
Phone: +47 31 29 10 50
kjell@beko-technologies.no

España / Spain

BEKO Tecnológica España S.L.
Polígono Industrial "Armenteres"
C./Primer de Maig, no.6
E-08980 Sant Feliu de Llobregat
Phone: +34 93 632 76 68
info.es@beko.de

South East Asia

BEKO TECHNOLOGIES S.E.Asia (Thai-
land) Ltd.
75/323 Romkiao Road
Sansab, Minburi
Bangkok 10510
Thailand
Phone: +66 (0) 2-918-2477
BEKO-info@beko-seasia.com

臺灣 / Taiwan

BEKO TECHNOLOGIES Co.,Ltd
16F.-5, No.79, Sec. 1,
Sintai 5th Rd., Sijhih City,
Taipei County 221,
Taiwan (R.O.C.)
Phone: +886 2 8698 3998
info@beko.com.tw

Česká Republika / Czech Republic

BEKO TECHNOLOGIES s.r.o.
Mlýnská 1392
CZ - 562 01 Usti nad Orlici
Phone: +420 465 52 12 51
info.cz@beko.de

United Kingdom

BEKO TECHNOLOGIES LTD.
2 West Court
Buntsford Park Road
Bromsgrove
GB-Worcestershire B60 3DX
Phone: +44 1527 575 778
beko@beko-uk.com

USA

BEKO TECHNOLOGIES CORP.
900 Great SW Parkway
US - Atlanta, GA 30336
Phone: +1 (404) 924-6900
beko@bekousa.com

1 Contents

1	Contents	3
2	Type plate	5
3	Safety instructions	5
3.1	Safety pictograms in accordance with DIN 4844	6
3.2	Signal words in accordance with ANSI	7
3.3	Overview of the safety instructions	7
4	Proper use	10
5	Exclusion from a field of application	10
6	Special advice for plants under pressure in accordance with the 97/23/EC Pressure Equipment Directive	10
7	Transport	11
8	Storage	11
9	Installation	12
9.1	Place of installation	12
9.2	Installation plan	13
9.3	Correction factors	14
9.4	Connection to the compressed-air system	15
9.5	Connection to the cooling-water network (water-cooled)	15
9.6	Electrical connections	16
9.7	Condensate drain	16
10	Start-up	17
10.1	Preliminary stages	17
10.2	Initial start-up	18
10.3	Removal from service and restart	19
11	Technical data	20
11.1	Technical data DRYPOINT RA 3-60 /AC	20
11.2	Technical data DRYPOINT RA 80-160 /AC	21
11.3	Technical data DRYPOINT RA 55-160 /WC	22
12	Technical description	23
12.1	Control panel	23
12.2	Functional description	23
12.3	Flow diagram (air-cooled)	24
12.4	Flow diagram (water-cooled)	24
12.5	Refrigerating compressor	25
12.6	Condenser (air-cooled)	25
12.7	Condenser (water-cooled)	25
12.8	Cooling-water controller	25
12.9	Filter dryer	26
12.10	Capillary tube	26
12.11	Aluminium heat exchanger	26
12.12	Hot gas bypass valve	26
12.13	Refrigerant pressure switches P_A - P_B - P_V	27
12.14	Safety temperature switch T_s	27
12.15	DMC 14 electronics (control unit compressed-air dryer)	28
12.16	Electronically level-controlled BEKOMAT condensate drain	29
13	Maintenance, troubleshooting, spare parts and dismantling	30
13.1	Checks and maintenance	30
13.2	Troubleshooting	31
13.3	Recommended spare parts	34
13.4	Maintenance works at the refrigeration cycle	35
13.5	Dismantling of the dryer	35
14	Appendices	36
14.1	Dryer dimensions	36
14.1.1	Dryer dimensions DRYPOINT RA 3-12 /AC	36
14.1.2	Dryer dimensions DRYPOINT RA 18-23 /AC	36
14.1.3	Dryer dimensions DRYPOINT RA 30-40 /AC	37
14.1.4	Dryer dimensions DRYPOINT RA 55-60/AC	37
14.1.5	Dryer dimensions DRYPOINT RA 80-100 /AC	38
14.1.7	Dryer dimensions DRYPOINT RA 55-60 /WC	39

Contents

14.1.8	Dryer dimensions DRYPOINT RA 80-100 /WC.....	39
14.1.9	Dryer dimensions DRYPOINT RA 120-160 /WC.....	39
14.2	Exploded diagram.....	40
14.2.1	Exploded diagram – diagram of the functional elements	40
14.2.2	Exploded diagram DRYPOINT RA 3-12.....	41
14.2.3	Exploded diagram DRYPOINT RA 18-23.....	42
14.2.4	Exploded diagram DRYPOINT RA 30-40.....	43
14.2.5	Exploded diagram DRYPOINT RA 55-60.....	44
14.2.6	Exploded diagram DRYPOINT RA 80-100.....	45
14.2.7	Exploded diagram DRYPOINT RA 120-160.....	46
14.3	Circuit diagrams.....	47
14.3.1	Circuit diagram – diagram of the functional elements	47
14.3.2	Circuit diagram DRYPOINT RA 3-40.....	47
14.3.3	Circuit diagram DRYPOINT RA 55-60.....	48
14.3.4	Circuit diagram DRYPOINT RA 80-160	48

2 Type plate

The type plate is on the back of the dryer and comprises all primary data of the device. Please complete the table on this page during the installation with all data from the type plate and always refer to these when contacting the manufacturer or the sales department.

All guarantee claims will expire in the event that the type plate is modified or removed.

Model	⇒
Product key	⇒
Serial number	⇒
Nominal flow rate	⇒
Operating overpressure PS min/max	⇒
Inlet temperature TS max	⇒
Ambient temperature	⇒
Refrigerant	⇒
Refrig. Design pressure HP/LP	⇒
Electrical connection	⇒
Electric power	⇒
Fuse protection max.	⇒

DRYPOINT	
Produktschlüssel: Product key:	<input type="text"/>
Serienr. / Baujahr: Serial n° / year of building:	<input type="text"/>
Nemmvolumenstrom (ISO1217): Nominal flow rate (ISO1217):	<input type="text"/> m ³ /h
Betriebsüberdruck PS min/max: Working pressure PS min/max:	<input type="text"/> bar(g)
Eintrittstemperatur TS max: Inlet temperature TS max:	<input type="text"/> °C
Umgebungstemperatur: Ambient Temperature:	<input type="text"/> °C
Kältemittel: Refrigerant:	<input type="text"/> kg
Kältem. Auslegungsdruck HD/ND: Refrig. Design Pres. HP/LP:	<input type="text"/> bar
Elektrischer Anschluß: Power supply:	<input type="text"/> ph/V/Hz
Elektrische Leistung: Electric Nominal Power:	<input type="text"/> W/A
Absicherung max: Fuse protection max:	<input type="text"/> A



TAD0003

BEKO TECHNOLOGIES GMBH
Im Taubental 7, 41468 Neuss
Germany
[http:// www.beko.de](http://www.beko.de)



3 Safety instructions



Please check whether or not these instructions correspond to the device type.

Please adhere to all advice given in these operating instructions. They include essential information which must be observed during installation, operation and maintenance. Therefore, it must be ensured that these operating instructions are read by the fitter and the responsible operator / certified skilled personnel prior to installation, start-up and maintenance.

The operating instructions must be accessible at all times at the place of application of the DRYPOINT® RA 3-160 compressed-air refrigeration dryer.

In addition to these operating instructions, local and national regulations need to be observed, where required.

Ensure that operation of the DRYPOINT® RA 3-160 compressed-air refrigeration dryer only takes place within the permissible limit values indicated on the type plate. Any deviation from these limit values involves a risk for persons and for the material, and may result in malfunction or a breakdown.

After installing the device correctly and in accordance with the instructions in this manual, the dryer is ready to operate, further settings are not required. Operation is fully automatic and maintenance is limited to several examinations and cleaning measures which are described in the following chapters. This manual must be available at all times for future reference and is a constituent part of the dryer.

If you have any queries regarding these installation and operating instructions, please contact BEKO TECHNOLOGIES GMBH.

3.1 Safety pictograms in accordance with DIN 4844



Observe operating instructions



General danger symbol



Supply voltage



Danger: component or system under pressure



Hot surfaces



Non-breathable air



Do not use water to extinguish the fire



Do not operate with open cover (housing)



Maintenance works or controlling measures must only be carried out by qualified personnel¹.



Do not smoke



Note



Connection point compressed-air inlet



Connection point compressed-air outlet



Connection point condensate drain



Connection point cooling-water inlet (water-cooled)



Connection point cooling-water outlet (water-cooled)

3.2 Signal words in accordance with ANSI

Danger!	Imminent hazard Consequences of non-observance: serious injury or death
Warning!	Potential hazard Consequences of non-observance: possible serious injury or death
Caution!	Imminent hazard Consequences of non-observance: possible injury or property damage
Notice!	Potential hazard Consequences of non-observance: possible injury or property damage
Important!	Additional advice, info, hints Consequences of non-observance: disadvantages during operation and maintenance, no danger

3.3 Overview of the safety instructions



Certified skilled personnel

Installation works must exclusively be carried out by authorised and qualified skilled personnel. Prior to undertaking any measures on the DRYPOINT® RA 3-160 compressed-air refrigeration dryer, the certified skilled personnel shall read up on the device by carefully studying the operating instructions. The operator is responsible for the adherence to these provisions. The respective directives in force apply to the qualification and expertise of the certified skilled personnel.

For safe operation, the device must only be installed and operated in accordance with the indications in the operating instructions. In addition, the national and operational statutory provisions and safety regulations, as well as the accident prevention regulations required for the respective case of application, need to be observed during employment. This applies accordingly when accessories are used.



Danger!

Compressed air!

Risk of serious injury or death through contact with quickly or suddenly escaping compressed air or through bursting and/or unsecured plant components.

Compressed air is a highly dangerous energy source.

Never work on the dryer when the system is under pressure.

Never direct the compressed-air outlet or condensate drain hoses at persons.

The user is responsible for the proper installation of the dryer. Non-observance of the instructions in the "Installation" chapter leads to the expiration of the guarantee. Improper installation may result in dangerous situations for the personnel and/or the device.



Danger!

Supply voltage!

Contact with non-insulated parts carrying supply voltage involves the risk of an electric shock resulting in injuries and death.

Only qualified and skilled personnel are authorised to run electrically-operated devices. Prior to undertaking maintenance measures at the device, the following requirements must be met:

Make sure that the power supply is switched off and that the device is off and marked for maintenance measures. Please also ensure that the power supply cannot be re-established during the works.



Caution!

Refrigerant!

The compressed-air refrigeration dryer uses HFC-containing refrigerants as a coolant.

Please observe the corresponding paragraph entitled "Maintenance works at the refrigeration cycle".



Warning!

Refrigerant leak!

A refrigerant leak involves the danger of serious injury and damage to the environment.

Safety instructions



The DRYPOINT® RA 3-160 compressed-air refrigeration dryer contains fluorinated greenhouse gas/refrigerant.

Installation, repair and maintenance works at the refrigeration system must only be carried out by certified skilled personnel (specialists). A certification in accordance with EC regulation 303/2008 must be available.



The requirements of the EC 842/2006 directive must be met under all circumstances.

Please refer to the indications on the type plate as regards the type and amount of refrigerant.



Comply with the following protective measures and rules of conduct:



- **Storage:** Keep the container tightly closed. Keep it in a cool and dry place. Protect it against heat and direct sunlight. Keep it away from ignition sources.
- **Handling:** Take measures against electrostatic charging. Ensure good ventilation/suction at the workplace. Check fittings, connections and ducts for tightness. Do not inhale the gas. Avoid contact with the eyes or the skin.
- Prior to carrying out works on refrigerant-carrying parts, remove the refrigerant to such an extent that safe working is possible.
- Do not eat, drink or smoke during work. Keep out of the reach of children.
- **Breathing protection:** ambient-air-independent respirator (at high concentrations).
- **Eye protection:** sealing goggles.
- **Hand protection:** protective gloves (e.g. made of leather).
- **Personal protection:** protective clothing.
- **Skin protection:** use protective cream.

In addition, the safety data sheet for the refrigerant needs to be observed!



Caution!

Hot surfaces!

During operation, several components can reach surface temperatures of more than +60°C. There is the risk of burns.

All components concerned are installed inside of the closed housing. The housing must only be opened by certified skilled personnel.



Caution!

Improper use!



The device is intended for the separation of water in compressed air. The dried compressed air cannot be used for breathing-air purposes and is not suitable for the direct contact with food.

This dryer is not suitable for the treatment of contaminated air or of air containing solids.



Note!

Contaminated intake air!

In the event that the intake air is strongly contaminated (ISO 8573.1 class 3.-3 or poorer quality), we recommend the additional installation of a prefilter (e.g. CLEARPOINT F040), to avoid clogging of the heat exchanger.



Caution!

Heating-up through fire!

In the event of a heating-up through fire, the containers and pipes of the refrigerant system can burst.



In this case, please proceed as follows:

Switch off the refrigeration plant.

Switch off the mechanical ventilation of the machinery compartment.

Use ambient-air-independent respirators.

Containers and plants which are filled with refrigerant can burst violently in the event of fire.

The refrigerants themselves are incombustible, but they are degraded to very toxic products at high temperatures.

Remove the container/plant from the fire zone, as there is the risk of bursting!

Cool down containers and bottles via a directed water jet from a safe position.

In the event of fire, please use an approved fire extinguisher. Water is not a suitable agent to extinguish an electrical fire.

This must only be carried out by persons who are trained and informed about the hazards emanating from the product.



Caution!

Unauthorised intervention!

Unauthorised interventions may endanger persons and plants and lead to malfunction.

Unauthorised interventions, modification and abuse of the pressure devices are prohibited.

The removal of sealings and leadings at safety devices is prohibited.

Operators of the devices must observe the local and national pressure equipment regulations in the country of installation.



Note!

Ambient conditions!

In the event that the dryer is not installed under suitable ambient conditions, the ability of the device to condense refrigerant gas is impaired. This can result in a higher load of the refrigerating compressor, and in a loss of efficiency and performance of the dryer.

This in turn leads to overheated condenser fan motors, to malfunction of electric components and to a breakdown of the dryer.

Do not install the dryer in an environment in which chemicals with a corrosive effect, explosive gases, toxic gases, evaporation heat, high ambient temperatures or extreme dust and dirt can be found.

4 Proper use

This dryer was designed, manufactured and tested to separate the moisture which normally exists in compressed air. Any other use is considered improper.

The manufacturer shall not be liable for problems occurring as a consequence of improper use. The user alone is responsible for any damage resulting from that.

Furthermore, the correct use includes the compliance with the installation instructions, in particular in respect of:

The voltage and frequency of the main voltage supply.

The pressure, temperature and flow rate of the inlet air.

The pressure, temperature and cooling-water throughput (water-cooled).

The ambient temperature.

When delivered, the dryer is tested and fully assembled. The customer only needs to connect the device to the system in accordance with the instructions in the following chapters.

5 Exclusion from a field of application



Note!
Improper use!



The device is intended for the separation of water in compressed air. The dried compressed air cannot be used for breathing-air purposes and is not suitable for the direct contact with food.

This dryer is not suitable for the treatment of contaminated air or of air containing solids.

6 Special advice for plants under pressure in accordance with the 97/23/EC Pressure Equipment Directive

The DRYPOINT® RA 3-160 compressed-air refrigeration dryer contains pressure equipment in the sense of the 97/23/EC Pressure Equipment Directive. Therefore, the entire plant needs to be registered with the supervisory authority in accordance with the local regulations, and requires the approval of the latter.

The category of the respective pressure device is indicated in the declaration of conformity.

For the examination prior to the start-up and for periodic inspections, the national regulations need to be observed, such as the industrial safety regulation in the Federal Republic of Germany. In countries outside the EU, the respective regulations in force there need to be adhered to.

The proper use of pressure devices is the basic requirement for safe operation. As regards pressure devices, the following points need to be observed:

- The DRYPOINT® RA 3-160 compressed-air refrigeration dryer must only be employed within the pressure and temperature range limits indicated by the manufacturer on the type plate.
- No welding must be carried out on the housing and bottom of the devices.
- The DRYPOINT® RA 3-160 compressed-air refrigeration dryer must neither be installed in insufficiently ventilated rooms nor near heat sources or inflammable substances.
- To avoid fractures resulting from material fatigue, the refrigeration dryer should not be exposed to vibrations during operation.
- The maximum operating pressure indicated by the manufacturer on the type plate must not be exceeded. It is the operator's responsibility to install the appropriate safety and control devices. Prior to the start-up of the DRYPOINT® RA 3-160 compressed-air refrigeration dryer, the connected pressure generator (compressor etc.) must be fused to the max. permissible operating pressure. The integrated safeguard needs to be checked by an approved inspection agency.
- The documents related to the DRYPOINT® RA 3-160 compressed-air refrigeration dryer (manual, operating instructions, manufacturer's declaration etc.) must be kept safe for future reference.
- No objects whatsoever must be installed at or placed on the DRYPOINT® RA 3-160 compressed-air refrigeration dryer and the connecting lines.
- Installation of the plant in frost-free places only.
- Operation of the plant is only permissible with fully closed and intact housing and cover panels. Operation of the plant with damaged housing/cover panels is prohibited.

7 Transport

Check the packaging for visible loss or damage. If no visible damage can be ascertained, place the unit in close proximity to the place of installation and unpack the device.

During this procedure, the dryer must always remain in an upright position. The components may be damaged when the unit is tilted or turned upside down.

Store the device in a dry environment and do not expose it to extreme weather conditions.

Handle with care. Strong shocks can cause irreparable damage.

8 Storage

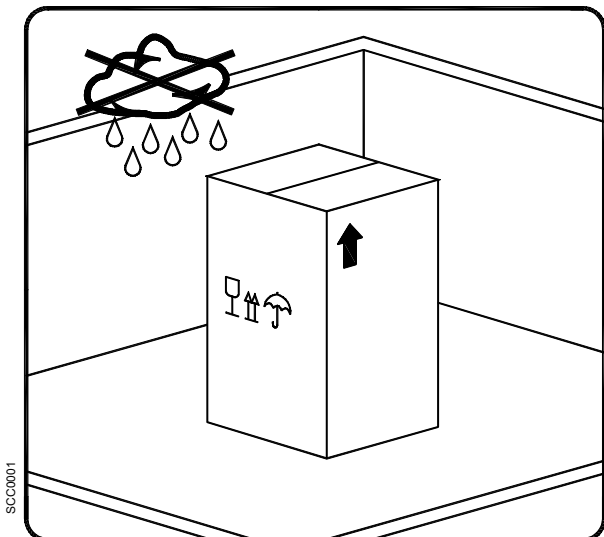

Keep the device away from extreme weather conditions even when packaged.

Keep the dryer in an upright position, also while it is stored. Tilting the device or turning it upside down can cause irreparable damage to some components.

When the dryer is not in use, it can be stored in its packaging in a dust-free and protected place at a temperature of up to max. 50°C and at a specific humidity of max. 90%. If the storage period exceeds 12 months, you should contact the manufacturer.

The packaging material is recyclable. Dispose of the material in accordance with the directives and provisions in force in the country of destination.

9 Installation

9.1 Place of installation



Note!

Ambient conditions!

In the event that the dryer is not installed under suitable ambient conditions, the ability of the device to condense refrigerant gas is impaired. This can result in a higher load of the refrigerating compressor, and in a loss of efficiency and performance of the dryer.

This in turn leads to overheated condenser fan motors, to malfunction of electric components and to a breakdown of the dryer.

Do not install the dryer in an environment in which chemicals with a corrosive effect, explosive gases, toxic gases, evaporation heat, high ambient temperatures or extreme dust and dirt can be found.

Minimum installation requirements

Choose an area which is clean and dry, free from dust and protected against atmospheric disturbances.

The load-bearing zone must be even, horizontal and able to bear the weight of the dryer.

Minimum ambient temperature +1°C.

Maximum ambient temperature 50°C.

Leave a free area of at least one metre in all directions of the dryer. This space is necessary to facilitate maintenance works.

The dryer does not need bottom attachment. However, in installations in which the device is suspended, an attaching part will be required for the suspended device.

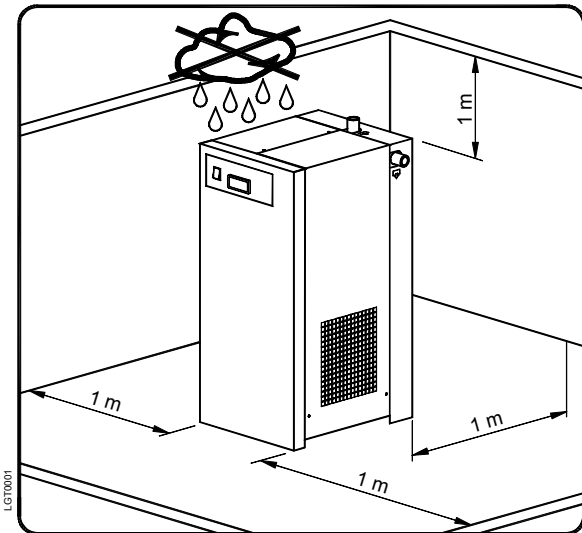

Dryer DRYPOINT RA 3-23, suspended:

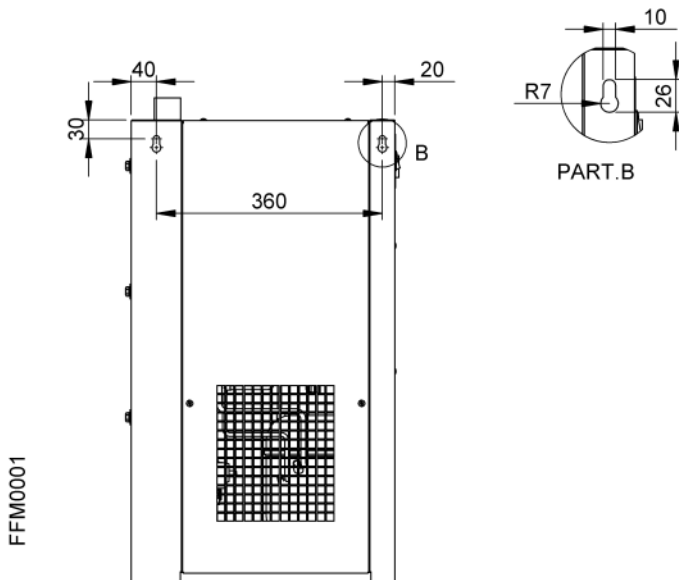

Part. B = Teil B

9.2 Installation plan

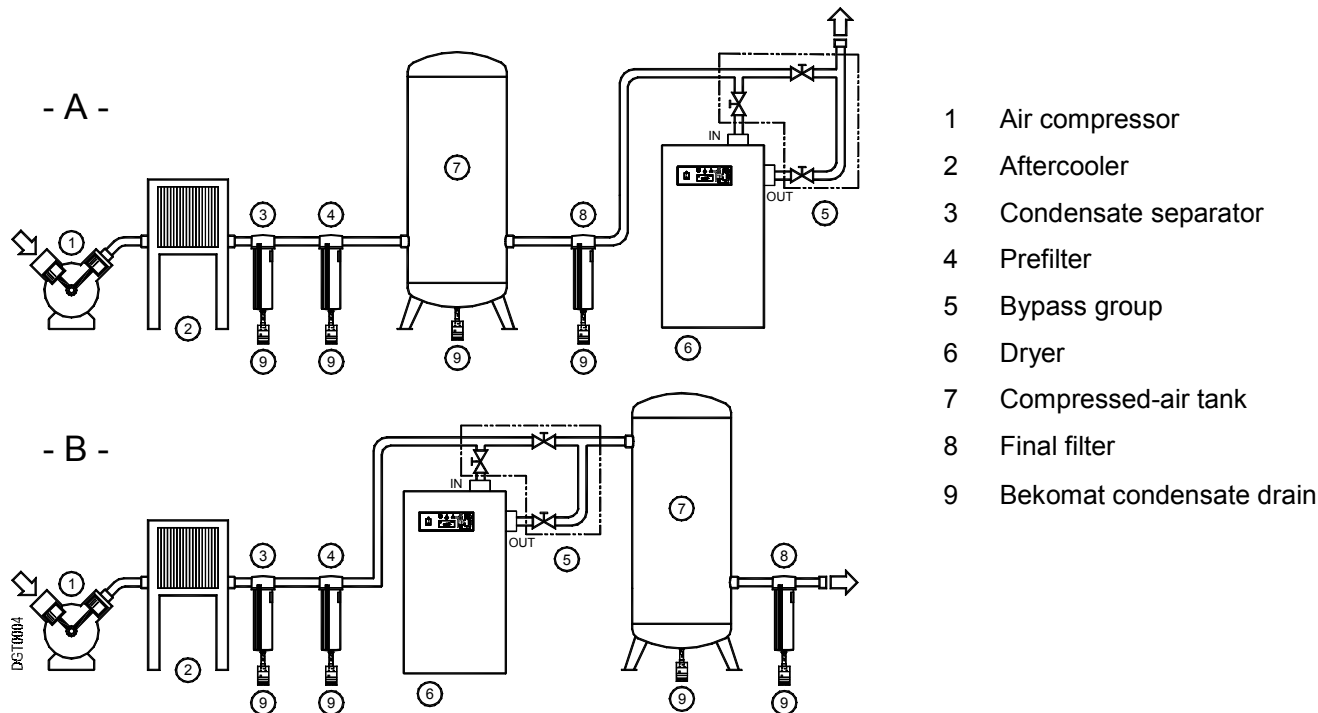

Installation **type A** is recommended when the compressor functions with reduced step switching and when the total consumption corresponds to the throughput rate of the compressor.

Installation **type B** is recommended when the air consumption constantly varies, with peak values which considerably exceed the throughput rate of the compressor. The storage capacity of the tank must be dimensioned in such a way that a possible short-term high air demand (peak air consumption) can be compensated.



Note!

Contaminated intake air!

In the event that the intake air is strongly contaminated (ISO 8573.1 class 3.-3 or poorer quality), we recommend the additional installation of a prefilter (e.g. CLEARPOINT F040), to avoid clogging of the heat exchanger.

Installation

9.3 Correction factors

Correction factor for operating pressure modifications:										
Air inlet pressure bar(g)	4	5	6	7	8	10	12	14	15	16
Factor (F1)	0,77	0,86	0,93	1,00	1,05	1,14	1,21	1,27	1,30	1,30

Correction factor for ambient temperature modifications (air-cooled):						
Ambient temperature °C	≤ 25	30	35	40	45	50
Factor (F2)	1,00	0,99	0,97	0,93	0,88	0,81

Correction factor for inlet air temperature modifications:										
Air temperature °C	≤ 25	30	35	40	45	50	55	60	65	70
Factor (F3)	1,27	1,12	1,00	0,88	0,78	0,70	0,62	0,55	0,49	0,43

Correction factor for dew point modifications:				
Dew point °C	3	5	7	10
Factor (F4)	1,00	1,09	1,19	1,37

Calculation of the air throughput:
Air throughput = nominal capacity x factor (F1) x factor (F2) x factor (F3) x factor (F4)
Example: The RA 40 has a nominal capacity of 240 m³/h . Which is the max. permissible flow through the dryer under the following operating conditions? <ul style="list-style-type: none"> - Air inlet pressure = 8 bar(g) ⇒ Factor (F1) = 1.05 - Ambient temperature = 45°C ⇒ Factor (F2) = 0.88 - Air inlet temperature = 50°C ⇒ Factor (F3) = 0.70 - Pressure dew point = 10°C ⇒ Factor (F4) = 1.37 Every data element has a corresponding numerical factor, which, multiplied with the nominal capacity, is as follows: Air throughput = 240 x 1.05 x 0.88 x 0.70 x 1.37 = 212 m³/h 212 m³/h This is the maximum throughput rate for a dryer under these operating conditions.

Selection of a suitable dryer for a given task:
Min. air throughput = $\frac{\text{required nominal capacity}}{\text{factor (F1) x factor (F2) x factor (F3) x factor (F4)}}$
Example: With the following operating parameters: <ul style="list-style-type: none"> - Required nominal capacity = 180 m³/h - Air inlet pressure = 8 bar(g) ⇒ Factor (F1) = 1.05 - Ambient temperature = 45°C ⇒ Factor (F2) = 0.88 - Air inlet temperature = 50°C ⇒ Factor (F3) = 0.70 - Pressure dew point = 10°C ⇒ Factor (F4) = 1.37 For the selection of the suitable dryer type, the required air flow must be divided by the correction factors of the parameters indicated above: Min. air throughput = $\frac{180}{1.05 \times 0.88 \times 0.70 \times 1.37} = 203 \text{ m}^3/\text{h}$ The suitable model is, therefore, DRYPOINT RA 40 (240 m ³ /h – nominal capacity).

9.4 Connection to the compressed-air system



Danger!
Compressed air!

All works must only be carried out by qualified skilled personnel.
Never work on compressed-air systems which are under pressure.



The operator or the user must ensure that the dryer is never operated with a pressure exceeding the maximum pressure value indicated on the type plate.
Exceeding the maximum operating pressure can be dangerous for the operator but also for the device.

The air temperature and the air flow at the inlet of the dryer must lie within the limit values indicated on the type plate. The connecting lines must be free from dust, iron rust, shards and other contaminations and correspond to the flow rate of the dryer. Should air with a very high temperature be treated, the installation of an aftercooler may be necessary. For the implementation of maintenance works, the installation of a bypass system is recommended, as is shown in the following illustration.

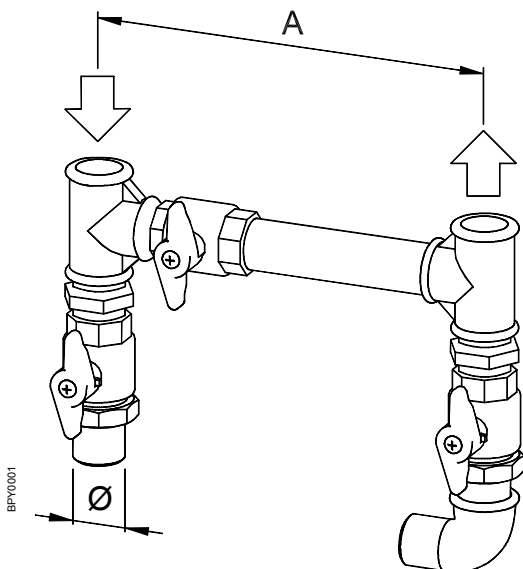

Dryer	Ø [BSP-F]	A [mm]
DRYPOINT RA 3-12	1/2"	210
DRYPOINT RA 18-23	1"	205
DRYPOINT RA 30-40	1.1/4"	205
DRYPOINT RA 55-60	1.1/2"	235
DRYPOINT RA 80-100	2"	345
DRYPOINT RA 120-160	2.1/2"	410

The dryer was designed in such a manner that vibrations that may occur during operation are limited. Therefore, it is advisable to employ connecting lines (flexible hoses, vibration-inhibiting fittings etc.) which protect the dryer against possible vibrations in the pipework.

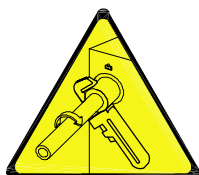

Note:

During the piping of the dryer, the inlet and outlet connections need to be fixed in position, as is shown in the illustration.
Non-observance will cause damage.

9.5 Connection to the cooling-water network (water-cooled)



Danger!
Compressed air and unqualified personnel!

All works must only be carried out by qualified skilled personnel.
Never work on compressed-air systems which are under pressure.



The user must ensure that the dryer is never operated with a pressure exceeding the nominal values.
Possible overpressure can be dangerous for the operator but also for the device.

The temperature and the amount of cooling water need to correspond to the limit values indicated on the type plate. The cross-section of the connecting lines which should preferably be flexible, must be free from dust, iron rust, shards and other contaminations. We recommend employing connecting lines (flexible hoses, vibration-inhibiting fittings etc.) which protect the dryer against possible vibrations in the pipework.

9.6 Electrical connections



Danger!

Supply voltage!

The connection to the electric mains should only be carried out by qualified skilled personnel and must correspond to the legal provisions in force in your region.

Prior to connecting the device, please check the type plate to avoid exceeding the indicated values. The voltage tolerance is +/- 5%.

DRYPOINT RA 3-60 dryers are supplied with a VDE 16A standard power cord and safety plug (two-pole and earth connection). DRYPOINT RA 80-160 devices have a junction box on the back plate.

Make sure that suitable fuses or circuit breakers in accordance with the indications on the type plate are available.

The wall socket must be equipped with a fault current circuit breaker ($I_{\Delta n}=0,03A$) which must be adjusted according to the power consumption of the dryer (see nominal values on the type plate of the dryer). The cross-section of the power supply cable must correspond to the power consumption of the dryer. In this respect, the ambient temperature, the cable laying conditions, the length of the cables and the requirements of the local electricity supplier need to be considered.



Danger!

Supply voltage and missing earth connection!

Important: ensure that the plant is connected to earth.

Do not use plug adapters at the power plug.

Possible replacement of the power plug must only be carried out by a qualified electrician.

9.7 Condensate drain



Danger!

Compressed air and condensate under pressure!

The condensate is discharged at system pressure.

The drain pipe needs to be secured.

Never direct the condensate drain pipe at persons.



The dryer is delivered with an already integrated electronically level-controlled BEKOMAT condensate drain. Connect the condensate drain with a collection system or container by properly screwing it on.

Do not connect the drain with pressure plants.



Do not discharge the condensate into the environment.

The condensate accumulating in the dryer contains oil particles which were released into the air by the compressor.

Dispose of the condensate in accordance with the local provisions.

It is advisable to install a water-oil separator, to which the total amount of condensate from the compressors, dryers, tanks, filters etc. is supplied.

We recommend ÖWAMAT oil-water separators for dispersed compressor condensate and BEKOSPLIT emulsion-splitting plants for emulsified condensate.

10 Start-up

10.1 Preliminary stages

**Note!****Exceeding of the operating parameters!**

Ensure that the operating parameters comply with the nominal values indicated on the type plate of the dryer (voltage, frequency, air pressure, air temperature, ambient temperature etc.).

Prior to delivery, this dryer was thoroughly tested, packed and checked. Please verify the soundness of the dryer during the initial start-up and check the perfect functioning during the first operating hours.



The initial start-up must be carried out by qualified personnel.

During the installation and operation of this device, all national regulations regarding electronics and any other federal and state ordinances, as well as local provisions, need to be adhered to.

The operator and the user must ensure that the dryer is not operated without panels.



10.2 Initial start-up



Note:

The dryer **must not be started up more than six times an hour**. Wait at least five minutes prior to every restart.

The user is responsible for the compliance with these provisions. Irreparable damage can be caused by starting up the device too often.



The method below should be applied during the first start-up, after longer downtimes or subsequent to maintenance works.

The start-up must be carried out by certified skilled personnel.

Processing sequence (observe Article 5.1 "Control panel")

- Ensure that all steps of the "Installation" chapter have been carried out.
- Ensure that the connection to the compressed-air system is in accordance with the provisions and that the lines are fixed and supported properly.
- Ensure that the condensate offtake pipe is fixed in accordance with the provisions and that it is connected with a collection container or system.
- Ensure that the bypass system (if available) is open and that the dryer is disconnected from the compressed-air system.
- Ensure that the manual valve of the condensate drain cycle is closed.
- Ensure that the cooling-water flow and the cooling-water temperature are in accordance with the provisions (water-cooled).
- Remove any packaging material and other items which may block the space around the dryer.
- Establish the mains connection (plug into wall socket).
- Start the dryer by switching on the main switch on the control panel (pos. 1).
- Ensure that the DMC 14 electronics are switched on.
- Ensure that the power consumption complies with the values on the type plate.
- **Ensure that the fan functions properly – wait for the first interventions (air-cooled).**
- Wait until the dew point remains stable.
- Slowly open the air inlet valve.
- Slowly open the air outlet valve.
- Slowly close the central bypass valve of the system (if available).
- Check the pipes for air leakage.
- Ensure the proper functioning of the condensate drain cycle– wait for the first condensate discharges.



Note:

A dew point between 0°C and +10°C displayed on the DMC 14 control unit is considered to be correct according to the possible operating conditions (flow rate, air inlet temperature, ambient temperature etc.).

During the operation, the refrigerating compressor runs continuously. The dryer needs to be switched on during the entire compressed-air usage time, even if the compressed-air compressor is in operation only periodically.

10.3 Removal from service and restart



Removal from service (observe Article 5.1 "Control panel")

- Check whether or not the dew point temperature which is indicated on the display of the DMC 14 electronics is stable.
- Interrupt the compressed-air supply.
- Remove the dryer from service after several minutes via the main switch on the control panel. (pos. 1).



Restart (observe Article 5.1 "Control panel")

- Make sure that the condenser is clean (air-cooled).
- Ensure that the cooling-water flow and the temperature are in accordance with the provisions (water-cooled).
- Check whether or not supply voltage is applied at the dryer.
- Start the dryer by switching on the main switch on the control panel (pos. 1).
- Ensure that the DMC 14 electronics are switched on.
- Wait for several minutes and then check whether or not the dew point temperature which is indicated on the display of the DMC 14 electronics is stable and whether or not the condensate is discharged at regular intervals.
- Establish the compressed-air supply.

During the operation, the refrigerating compressor runs continuously. The dryer needs to be switched on during the entire compressed-air usage time, even if the compressed-air compressor works periodically.



Note:

A dew point between 0°C and +10°C displayed on the DMC 14 control unit is considered to be correct according to the possible operating conditions (flow rate, air inlet temperature, ambient temperature etc.).



Note:

The dryer **must not be started up more than six times an hour**. Wait at least five minutes prior to every restart.

The user is responsible for the compliance with these provisions. Irreparable damage can be caused when starting up the device too often.

11 Technical data

11.1 Technical data DRYPOINT RA 3-60 /AC

Model DRYPOINT RA	Air-cooled												
	3	5	8	12	18	23	30	40	55	60			
Nominal capacity at nominal condition ¹	[l/min]	350	550	850	1200	1800	2300	3100	4000	5500	6200		
	[m ³ /h]	21	33	51	72	108	138	186	240	330	372		
	[scfm]	12	19	30	42	64	81	109	141	194	219		
Pressure dew point at nominal condition ¹	[°C]	+3 equals 0,73 g/m ³ H ₂ O											
Nominal ambient temperature (max.)	[°C]	+25 (+50)											
Min. ambient temperature	[°C]	+1											
Nominal inlet air temperature (max.)	[°C]	+35 (+70)											
Nominal inlet air pressure	[bar(ü)]	7											
Max. inlet air pressure	[bar(ü)]	16											
Air pressure drop - Δp	[bar]	0,02	0,03	0,08	0,11	0,13	0,17	0,15	0,20	0,15	0,18		
Inlet/outlet air connections	[BSP-F]	G 1/2"		G 1"		G 1.1/4"		G 1.1/2"					
Type of refrigerant		R134.a						R404A					
Amount of refrigerant ³	[kg]	0,21	0,21	0,23	0,27	0,30	0,35	0,42	0,48	0,70	0,80		
Cooling air-fan current	[m ³ /h]	200		300		380						450	
Cooling-water volume flow IN:15°C, OUT:30°C	[m ³ /h]	-											
Cooling-water volume flow IN:30°C, OUT: 40°C	[m ³ /h]	-											
Control of the cooling-water flow		-											
Maximum water temperature ²	[°C]	-											
Min. (max.) water pressure	[bar(ü)]	-											
Cooling-water connections	[BSP-F]	-											
Standard power supply ³	[Ph/V/H]	1/230 – 240/50 – 1/230/60						1/230 – 240/50					
Electr. nominal capacity	[W]	150	180	220	300	430	460	690	790	820	920		
Nominal power consumption 50 Hz	[A]	1	1,1	1,4	1,9	2,4	2,6	3,7	3,9	4,0	4,4		
Max. electr. power input	[W]	200	220	250	350	540	670	950	1100	1150	1400		
Max. power consumption 50 Hz	[A]	1,2	1,3	1,5	2,1	3,1	3,5	5,1	5,3	5,6	6,4		
Max. sound level at 1m	[dba]	< 70											
Weight	[kg]	28	29	31	34	36	37	46	50	55	63		

¹ The nominal condition relates to an ambient temperature of +25°C with an inlet air of 7 bar(g) and +35 °C.

² Other temperatures upon request.

³ Check the indications on the type plate.

11.2 Technical data DRYPOINT RA 80-160 /AC

Model DRYPOINT RA	Air-cooled					
	80	100	120	140	160	
Nominal capacity at nominal condition ¹	[l/min]	8100	10500	12500	14500	16000
	[m ³ /h]	486	630	750	870	960
	[scfm]	286	371	441	512	565
Pressure dew point at nominal condition ¹	[°C]	+3 equals 0,73 g/m ³ H ₂ O				
Nominal ambient temperature (max.)	[°C]	+25 (+50)				
Min. ambient temperature	[°C]	+1				
Nominal inlet air temperature (max.)	[°C]	+35 (+70)				
Nominal inlet air pressure	[bar(g)]	7				
Max. inlet air pressure	[bar(g)]	14				
Air pressure drop - Δp	[bar]	0,09	0,13	0,07	0,13	0,15
Inlet/outlet air connections	[BSP-F]	G 2" G 2.1/2"				
Type of refrigerant		R404A				
Amount of refrigerant ³	[kg]	1,25	1,30	1,85	2,1	2,3
Cooling-air fan current	[m ³ /h]	1900				
Cooling-water volume flow IN:15°C, OUT:30°C	[m ³ /h]	-				
Cooling-water volume flow IN:30°C, OUT:	[m ³ /h]	-				
Control of the cooling water flow		-				
Maximum water temperature ²	[°C]	-				
Min. (max.) water pressure	[bar(g)]	-				
Cooling-water connections	[BSP-F]	-				
Standard power supply ³	[PhV/Hz]	1/230-240/50				
Electr. nominal capacity	[W]	1050	1150	1380	1500	1530
Nominal power consumption 50 Hz	[A]	4,9	5,2	6,2	6,8	7,0
Max. electr. power input	[W]	1500	1700	2400	2550	2900
Max. power consumption 50 Hz	[A]	7,4	8,0	13,8	14,2	15,8
Max. sound level at 1 m	[dbA]	< 70				
Weight	[kg]	92	94	141	150	161

¹ The nominal condition relates to an ambient temperature of +25°C with an inlet air of 7 bar(g) and +35 °C.

² Other temperatures upon request.

³ Check the indications on the type plate.

11.3 Technical data DRYPOINT RA 55-160 /WC

Model DRYPOINT RA	Water-cooled						
	55	60	80	100	120	140	160
Nominal capacity at nominal condition	5500	6200	8100	10500	12500	14500	16000
[l/min]							
[m ³ /h]	330	372	486	630	750	870	960
[scfm]	194	219	286	371	441	512	565
Pressure dew point at nominal condition ¹	+3 equals 0,73 g/m ³ H ₂ O						
[°C]							
Nom. ambient temperature (max.)	+25 (+50)						
[°C]							
Min. ambient temperature	+1						
[°C]							
Nominal inlet air temperature (max.)	+35 (+70)						
[°C]							
Nominal inlet air pressure	7						
[bar(g)]							
Max. inlet air pressure	14						
[bar(g)]							
Air pressure drop - Δp	0,15	0,18	0,09	0,13	0,07	0,13	0,15
[bar]							
Inlet/outlet air connections	G 1.1/2"		G 2"		G 2.1/2"		
[BSP-F]							
Type of refrigerant	R404A						
Amount of refrigerant ³	0,70	0,80	0,95	1,0	1,30	1,50	1,70
[kg]							
Cooling-air fan current	-						
[m ³ /h]							
Cooling-water volume flow IN:15°C,	0,16	0,21	0,22	0,25	0,26	0,28	0,32
[m ³ /h]							
Cooling-water volume flow IN:30°C, OUT:	0,24	0,31	0,33	0,38	0,39	0,42	0,48
[m ³ /h]							
Control of the cooling-water flow	Automatically through valves						
Maximum water temperature ²	30						
[°C]							
Min. (max.) water pressure	3 (10)						
[bar(g)]							
Cooling-water connections	G 1/2"		G 3/4"				
[BSP-F]							
Standard power supply ³	1/230-240/50						
[Ph/V/Hz]							
Electr. Nominal capacity	750	850	920	1020	1250	1300	1350
[W]							
Nominal power consumption 50 Hz	3,7	4,1	4,3	4,6	5,6	5,9	6,1
[A]							
Max. electr. Power input	1080	1300	1370	1570	2270	2350	2700
[W]							
Max. power consumption 50 Hz	5,3	6,1	6,8	7,4	13,2	13,6	14,9
[A]							
Max. sound level at 1 m	< 70						
[dbA]							
Weight	53	61	89	91	138	147	158
[kg]							

¹ The nominal condition relates to an ambient temperature of +25°C with an inlet air of 7 bar(g) and +35 °C.

² Other temperatures upon request.

³ Check the indications on the type plate.

12 Technical description

12.1 Control panel

The control panel explained below is the only dryer user interface.

DRYPOINT RA 3 - 40

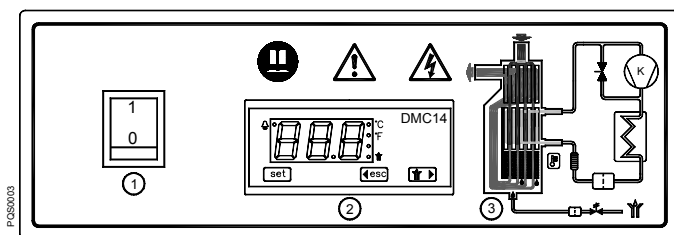

- 1 Main switch
- 2 DMC 14 electronics

DRYPOINT RA 55 - 160

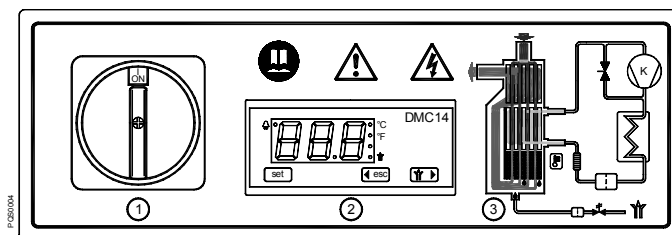

- 3 Air and refrigerant gas flow chart

12.2 Functional description

Operating principle – All dryer models described in this manual function according to the same principle. The hot and moisture-loaded air is led into an air/air heat exchanger. Afterwards, the air flows through an evaporator, which is also known as an air/refrigerant heat exchanger. The air temperature is reduced to approximately 2°C, so that water vapour condenses to liquid. The continuously accumulating condensate is collected in the separator to be discharged via the condensate drain. Subsequently, the cold and dry air is led through the air/air heat exchanger, so that it is reheated to up to 8°C below the inlet temperature when leaving the dryer.

Refrigeration cycle – The refrigerant is conducted through the compressor and reaches a condenser under high pressure. There, cooling-down takes place, making the refrigerant condense to a liquid state which is under high pressure. The liquid is pressed through a capillary tube where the resulting pressure drop ensures that the refrigerant evaporates at a defined temperature. The liquid refrigerant which is under low pressure is led into the heat exchanger, where it expands. The cold resulting from the expansion serves to cool down the compressed air in the heat exchanger. During this process, the refrigerant evaporates. The low-pressure gas is resupplied to the compressor, where it is compressed again. It then re-enters the cycle. In phases of a reduced compressed-air load, the excess refrigerant is resupplied automatically to the compressor via the hot gas bypass valve.

12.3 Flow diagram (air-cooled)

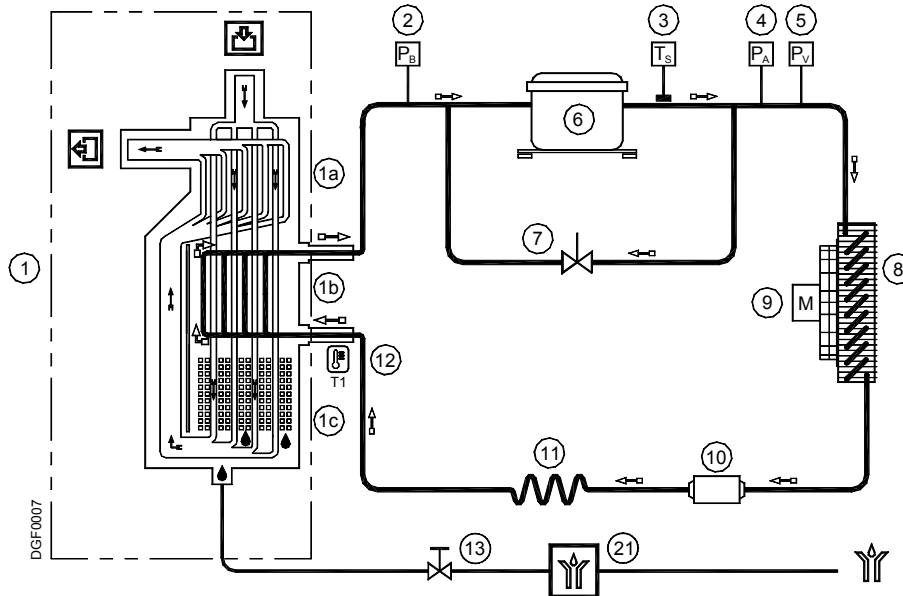

12.4 Flow diagram (water-cooled)

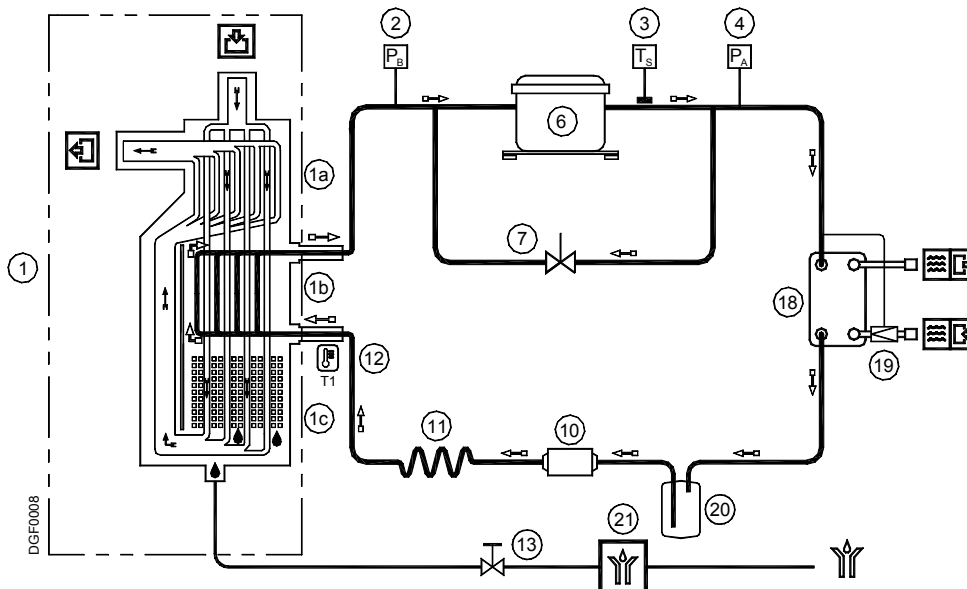

- | | | | |
|---|---|----|---|
| 1 | Aluminium heat exchanger module | 9 | Condenser fan |
| a | – Air/air heat exchanger | 10 | Filter dryer |
| b | – Air/refrigerant heat exchanger | 11 | Capillary tube |
| c | – Condensate drain | 12 | T1 temperature sensor (dew point) |
| 2 | Refrigerant pressure switch P _B (DRYPOINT RA 80-160) | 13 | Condensate drain shut-off valve |
| 3 | Safety temperature switch T _S (DRYPOINT RA 55-160) | 17 | Electric control unit |
| 4 | Refrigerant pressure switch P _A (DRYPOINT RA 80-160) | 18 | Condenser (water-cooled) |
| 5 | Refrigerant fan pressure switch P _V | 19 | Cooling-water controller (water-cooled) |
| 6 | Refrigerating compressor | 20 | Liquid collector (water-cooled) |
| 7 | Hot gas bypass valve | 21 | BEKOMAT condensate drain |
| 8 | Condenser (air-cooled) | | |
| → | Compressed-air flow direction | ⇨ | Refrigerant gas flow direction |

12.5 Refrigerating compressor

The gas from the evaporator (low-pressure side) is compressed to condensation pressure (high-pressure side). The employed refrigerating compressors are constructed by leading manufacturers and are designed for applications in which high compression rates are required and where strong temperature fluctuations exist.

The hermetically closed construction is absolutely gastight and guarantees a high energy yield and a long service life. Acoustical emissions and vibrations are reduced by damping springs. The induced refrigerant gas cools the electric motor. The integrated safeguard protects the compressor against overheating and excess current. The protection is automatically set back as soon as the nominal conditions are reached again.

12.6 Condenser (air-cooled)

The condenser is the component in which the gas coming from the compressor is cooled down, condensed and liquefied. From the mechanical point of view, the condenser consists of a zigzag copper pipe (through which gas flows) which is sheathed by an aluminium lamellae package.

Cooling-down takes place in the lamellae package through the air flow which is generated by a high-performance fan. Under no circumstances must the temperature of the ambient air exceed the nominal values. It is also important that the condenser unit is kept free from dust and other impurities.

12.7 Condenser (water-cooled)

The condenser is the component in which the gas coming from the compressor is cooled-down, condensed and liquefied.

The water inlet temperature must not exceed the nominal values. Likewise, a correct flow must be ensured. The water entering the condenser must be free from impurities.

12.8 Cooling-water controller

The cooling-water controller serves to keep the condensation pressure or the condensation temperature constant during water cooling. Via a capillary tube, the valve registers the pressure in the condenser and adjusts the water flow correspondingly. When the dryer is switched off, the valve automatically blocks the cooling-water flow.



Note!

The cooling-water controller is a control element.

Blocking of the water cycle through the cooling-water controller cannot serve as a safety shut-off measure during maintenance measures at the system.



Setting

The cooling-water controller is preset to a value during the test phase at the manufacturer, with which at least 90% of the applications can be covered. However, it is possible that extreme employment conditions of the dryer require a more precise calibration.

During the start-up, certified skilled personnel should verify the condensation pressure and temperature and adjust the valve accordingly, where required.

To increase the condensation temperature, turn the adjusting screw anticlockwise; to reduce it, turn it clockwise. Adjust the valve in such a manner that a condensation temperature of 42 to 45 °C is ensured.

12.9 Filter dryer

Despite controlled vacuuming, traces of moisture can accumulate in the refrigeration cycle. The filter dryer serves to absorb this moisture and to bond it.

12.10 Capillary tube

The capillary tube is a copper tube with a reduced diameter which is located between the condenser and the evaporator, serving as a restrictor to reduce the pressure of the refrigerant. The pressure reduction serves to reach an optimum temperature inside of the evaporator. The lower the outlet pressure at the capillary tube, the lower the evaporation temperature.

The length and the inner diameter of the capillary tube are exactly dimensioned to ensure the performance of the dryer. Settings or maintenance works are not required.

12.11 Aluminium heat exchanger

In the heat exchanger module, the air/air heat exchanger, the air/refrigerant heat exchanger, and the demister in the form of a condensate separator are accommodated. The compressed-air reverse current in the air/air heat exchanger guarantees maximum heat transfer. The large cross-section of the flow passage in the heat exchanger module causes low flow rates. Together with the gas flow in a reverse current, the generous dimensions of the air/refrigerant heat exchanger allow full evaporation of the refrigerant. This prevents moisture from entering the refrigerating compressor. The high-performance condensate separator is inside of the heat exchanger module. Maintenance is not necessary and the coalescence effect aims to achieve a high degree of moisture separation.

12.12 Hot gas bypass valve

At partial load, the valve directly returns a part of the hot gas to the suction line of the refrigerating compressor. The evaporation temperature/pressure remain constant at approximately +2 °C. This injection prevents an ice formation in the evaporator of the dryer under every load situation.



SETTING

The hot gas bypass valve is adjusted in the course of the production test phase. Normally, no setting is required. Should an adjustment nevertheless be necessary, it should be carried out by certified skilled personnel.

WARNING!

The connection of a check gauge to the 1/4" Schrader valve should only take place if the refrigeration system is actually disturbed. Each time a manometer is connected, parts of the refrigerant are lost.

Turn the adjusting screw (position A in the drawing), without compressed air flowing through the dryer, until the following values have been reached:

Hot gas setting (R134.a) :	Temperature 0,5 °C (+0,5 / -0 °K)
	Pressure 2,0 bar(g) (+0,1 / -0 bar)
Hot gas setting (R404A) :	Temperature 0,5 °C (+0,5 / -0 °K)
	Pressure 5,2 bar(g) (+0,1 / -0 bar)

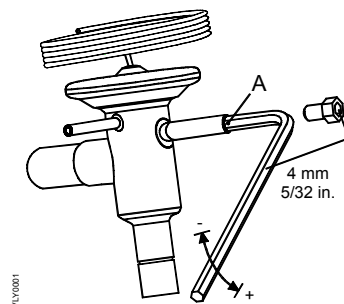

12.13 Refrigerant pressure switches P_A-P_B-P_V

To ensure the operational reliability and the protection of the dryer, a series of pressure switches are installed in the gas cycle.

- P_B** : Low-pressure switch on the suction side of the compressor, which is only activated when the pressure drops below the predetermined value. The values are reset automatically as soon as the nominal conditions are re-established.
Adjusted pressure: R 404 A Stop 1,0 bar(g) – Start 5,0 bar(g)
- P_A** : High-pressure switch on the pressure side of the compressor, which is activated when the pressure exceeds the predetermined value. Reset takes place manually via a button on the high-pressure controller.
Adjusted pressure: R 404 A Stop 32 bar(g) – manual reset
- P_V** : Fan pressure switch which is installed on the pressure side of the refrigerating compressor. It keeps the condensation temperature and pressure constantly in the range of the preadjusted limit values (air-cooled).
Adjusted pressure: R 134.a Start 11 bar(g) (47°C) - Stop 8 bar(g) (36°C) - Tolerance ± 1 bar
R 404 A Start 20 bar(g) (45°C) - Stop 16 bar(g) (36°C) -Tolerance ± 1 bar

12.14 Safety temperature switch T_S

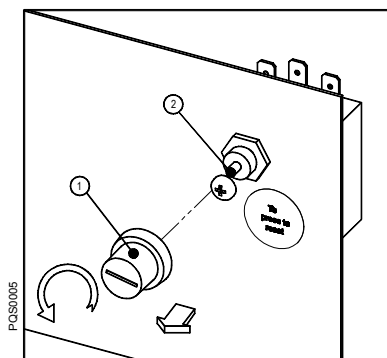

To ensure the operational reliability and the soundness of the dryer, a safety temperature switch (T_S) is installed at the refrigeration cycle. In the event that the pressure gas temperature is too high, the sensor of the temperature switch will stop the refrigerant compressor to prevent the pressure gas temperature getting too high.

The temperature switch is reset manually, but only when the normal operating conditions are reached again. Unscrew the cover (see pos. 1 in the illustration) and press the reset button (see position 2 in the illustration).

T_S - setting : temperature 100 °C (+2 / -2 °K)

Technical description

12.15 DMC 14 electronics (control unit compressed-air dryer)

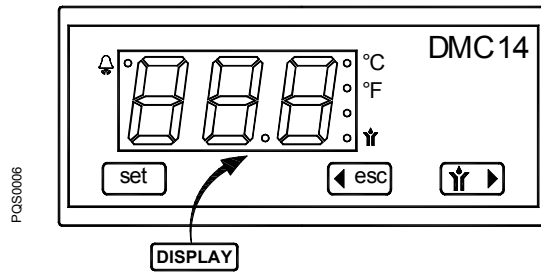

- key - Access to configuration.
- key - Leaving the programming mode / reduction of values.
- key - Increase of values.
- LED - Dryer in the alarm status.
- LED - Display of the selected temperature scale (°C).
- LED - Display of the selected temperature scale (°F).
- LED - Not assigned

Via a digital thermometer with an alphanumeric display, the DMC14 electronics indicate the dew point which is measured by the sensor in the evaporator.

The LED indicates possible alarm situations, for example:
 if the dew point is too high;
 if the dew point is too low;
 if the sensor is defective.

In the event that the sensor is defective, the message "PF" (Probe Failure) is also indicated and the alarm is immediately activated. In the event of a "Dew point too low" alarm message (fixed ASL parameter, corresponding to -2°C), the alarm signal is delayed (ADL parameter) by a fixed period of time of 30 seconds. For the "Dew point too high" message, the value (ASH parameter) is fixed by the user and the signal is activated with an ADH delay time which can also be set by the user (the control unit was already preset during the acceptance test of the dryer in the factory: see the following values). As soon as the dew point lies again in the adjusted operating temperature range, the alarm is deactivated.

The DMC 14 control unit also allows remote signalling of alarm situations of the dryer via a potential-free contact on terminals 8 and 9 – see enclosed circuit diagrams (max. 250V 1A, min. 5V DC 10mA): the contact is open when the dryer is switched off or in an alarm condition, and closed when the dryer is switched on and when the dew point is in accordance with the provisions.

OPERATING PRINCIPLE - When the dryer has been switched on, the electronic control unit indicates the current dew point: the measured temperature is expressed in °C (● °C) with a resolution of 0,5°C, or in Fahrenheit (● °F) with a resolution of 1°F.

PROGRAMMING

To get to the programming mode, simultaneously press the and the "dew point" button for at least five seconds. In this way, the **programming phase** is activated and the first adjustable parameter is indicated on the display (sound). When you press the button afterwards, the respectively adjusted value will appear on the display. If the value is correct, press the button to confirm it and to access the following parameters. To modify the value of a selected parameter (reduce or increase), use the and the button. All parameters which can be modified are listed in the table below:

Indication	Description	Setting range	Set value	equals
Sound	Not used	01 ... 20	01	-
ToF	Not used	01 ... 20	01	-
ASH	Alarm limit for a high dew point.	0,0 ... 20,0	15	15°C
AdH	ASH Alarm time preceding the signal	00 ... 20	20	20 min
SCL	Temperature scale	°C ... °F	°C	°Celsius
Fixed parameters:	ASL (alarm low dew point) = -2°C	AdL (signal delay) = 30 seconds		

The programming phase can be left at any time by simultaneously pressing the and the button. If, over a period of 30 seconds, no entry takes place, the programming phase is left automatically.

12.16 Electronically level-controlled BEKOMAT condensate drain

The electronically level-controlled BEKOMAT condensate drain boasts a special condensate management which ensures that condensate is discharged safely and without an unnecessary loss of compressed air. This drain has a condensate collection container in which a capacitive sensor continuously monitors the liquid level. As soon as the switching level is reached, the capacitive sensor transmits a signal to the electronic control and a membrane solenoid valve opens to discharge the condensate. The BEKOMAT closes before compressed air emerges.

**Note:**

These BEKOMAT condensate drains were designed in particular for the operation in a **DRYPOINT RA** refrigeration dryer. The installation in other compressed-air processing systems or the replacement with another drain marque can lead to disturbances. The maximum operating pressure (see type plate) must not be exceeded.

Ensure that the upstream valve is open when the dryer starts operation.

To obtain detailed information regarding drain functions, troubleshooting, maintenance and spare parts, please read the installation and operating instructions of the BEKOMAT condensate drain.

13 Maintenance, troubleshooting, spare parts and dismantling

13.1 Checks and maintenance



Certified skilled personnel

Installation works must exclusively be carried out by authorised and qualified skilled personnel. Prior to undertaking any measures on the DRYPOINT® RA 3-160 compressed-air refrigeration dryer, the certified skilled personnel shall read up on the device by carefully studying the operating instructions. The operator is responsible for the adherence to these provisions. The respective directives in force apply to the qualification and expertise of the certified skilled personnel.

For safe operation, the device must only be installed and operated in accordance with the indications in the operating instructions. In addition, the national and operational statutory provisions and safety regulations, as well as the accident prevention regulations required for the respective case of application, need to be observed during employment. This applies accordingly when accessories are used.



Danger!

Compressed air!

Risk of serious injury or death through contact with quickly or suddenly escaping compressed air or through bursting and/or unsecured plant components.

Compressed air is a highly dangerous energy source.

Never work on the dryer when the system is under pressure.

Never direct the compressed-air outlet or condensate drain hoses at persons.

The user is responsible for the proper maintenance of the dryer. Non-observance of the instructions in the "Installation" and "Maintenance, troubleshooting, spare parts and dismantling" chapters leads to the expiration of the guarantee. Improper maintenance may result in dangerous situations for the personnel and/or the device.



Danger!

Supply voltage!

Contact with non-insulated parts carrying supply voltage involves the risk of an electric shock resulting in injuries and death.

Only qualified and skilled personnel are authorised to run electrically-operated devices. Prior to undertaking maintenance measures at the device, the following requirements must be met:

Make sure that the power supply is switched off and that the device is off and marked for maintenance measures. Please also ensure that the power supply cannot be re-established during the works.



Prior to carrying out maintenance works at the dryer, switch it off and wait for at least 30 minutes.



Caution!

Hot surfaces!

During operation, several components can reach surface temperatures of more than +60°C. There is the risk of burns.

All components concerned are installed inside of the closed housing. The housing must only be opened by certified skilled personnel.

Some components can reach high temperatures during operation. Avoid any contact until the system or the component has cooled down.



DAILY:

Check whether the dew point indicated on the electronics is correct.

Ensure that the condensate drain system functions properly.

Make sure that the condenser is clean.

EVERY 200 HOURS OR MONTHLY



Clean the condenser using an air jet (max. 2 bar / 30 psig) inside out. Make sure not to damage the aluminium lamellae of the cooling package.

Finally, verify the operation of the device.



EVERY 1000 HOURS OR ANNUALLY



Verify all screws, clamps and connections of the electric system to make sure that they are fastened securely. Check the device for broken and ruptured cables or cables without insulation.

Check the refrigeration cycle for signs of oil and refrigerant leaks.

Measure the current strength and note it down. Ensure that the read values lie within the permissible limit values, as indicated in the specification table.

Check the hose lines of the condensate drain and replace them, if required.

Finally, verify the operation of the device.

13.2 Troubleshooting



Certified skilled personnel

Installation works must exclusively be carried out by authorised and qualified skilled personnel. Prior to undertaking any measures on the DRYPOINT® RA 3-160 compressed-air refrigeration dryer, the certified skilled personnel shall read up on the device by carefully studying the operating instructions. The operator is responsible for the adherence to these provisions. The respective directives in force apply to the qualification and expertise of the certified skilled personnel.

For safe operation, the device must only be installed and operated in accordance with the indications in the operating instructions. In addition, the national and operational statutory provisions and safety regulations, as well as the accident prevention regulations required for the respective case of application, need to be observed during employment. This applies accordingly when accessories are used.



Danger!

Compressed air!

Risk of serious injury or death through contact with quickly or suddenly escaping compressed air or through bursting and/or unsecured plant components.

Compressed air is a highly dangerous energy source.

Never work on the dryer when the system is under pressure.

Never direct the compressed-air outlet or condensate drain hoses at persons.

The user is responsible for the proper maintenance of the dryer. Non-observance of the instructions in the "Installation" and "Maintenance, troubleshooting, spare parts and dismantling" chapters leads to the expiration of the guarantee. Improper maintenance may result in dangerous situations for the personnel and/or the device.



Danger!

Supply voltage!

Contact with non-insulated parts carrying supply voltage involves the risk of an electric shock resulting in injuries and death.

Only qualified and skilled personnel are authorised to run electrically-operated devices. Prior to undertaking maintenance measures at the device, the following requirements must be met:

Make sure that the power supply is switched off and that the device is off and marked for maintenance measures. Please also ensure that the power supply cannot be re-established during the works.



Prior to carrying out maintenance works at the dryer, switch it off and wait for at least 30 minutes.



Caution!

Hot surfaces!





During operation, several components can reach surface temperatures of more than +60°C. There is the risk of burns.

Maintenance, troubleshooting, spare parts and dismantling

All components concerned are installed inside of the closed housing. The housing must only be opened by certified skilled personnel.

Some components can reach high temperatures during operation. Avoid any contact until the system or the component has cooled down.

FAULT	POSSIBLE REASON – SUGGESTED MEASURE
◆ The dryer does not start.	⇒ Check whether or not the connection with the electric mains is established. ⇒ Check the electric cabling.
◆ The refrigerating compressor does not work.	⇒ Activation of the internal heat protection of the compressor – wait 30 minutes and then retry. ⇒ Check the electric cabling. ⇒ If installed – replace the internal heat protection ad/or the start-up relay and/or the starting capacitor and/or the working capacitor. ⇒ If installed – pressure switch PA was activated – see the corresponding point. ⇒ If installed – pressure switch PB was activated – see the corresponding point. ⇒ If installed – safety temperature switch TS was activated – see the corresponding point. ⇒ In the event that the compressor still does not work, replace it.
◆ The fan of the condenser does not work (air-cooled).	⇒ Check the electric cabling. ⇒ The PV pressure switch is defective. Contact a BEKO service technician. ⇒ There is a leak in the refrigeration cycle – contact a BEKO service technician. ⇒ In the event that the fan still does not work, replace it.
◆ The dew point is too high.	⇒ The dryer does not start – see the corresponding point. ⇒ The T1 dew point sensor does not record the temperature properly – ensure that the sensor is pushed down to the bottom of the aluminium tube immersion sleeve. ⇒ The refrigerating compressor does not work – see the corresponding point. ⇒ The ambient temperature is too high or the room ventilation insufficient – ensure sufficient ventilation (air-cooled). ⇒ The inlet air is too hot – re-establish the nominal conditions. ⇒ The inlet air pressure is too low – re-establish the nominal conditions. ⇒ The inlet air throughput is higher than the throughput of the dryer – reduce the flow rate – re-establish the nominal conditions. ⇒ The condenser is dirty – please clean it (air-cooled). ⇒ The condenser fan does not work – see the corresponding point (air-cooled). ⇒ The cooling-water flow is insufficient – re-establish the nominal conditions (water-cooled). ⇒ The dryer does not drain the condensate – see the corresponding point. ⇒ The setting of the hot gas bypass valve is no longer correct – contact a BEKO service technician to have the nominal setting re-established.
◆ Dew point too low.	⇒ There is a leak in the refrigeration cycle – contact a BEKO service technician. ⇒ The fan is always ON – the P _V pressure switch is defective – replace it (air-cooled). ⇒ The ambient temperature is too low – re-establish the nominal conditions. ⇒ The setting of the hot gas bypass valve is no longer correct – contact a BEKO service technician to have the nominal setting re-established.
◆ Extreme pressure drop in the dryer.	⇒ The dryer does not drain the condensate – see the corresponding point. ⇒ The dew point is too low – the condensate is frozen and blocks the air – see the corresponding point. ⇒ Check the flexible connection hoses for restrictions.
◆ The dryer does not drain the condensate.	⇒ The shut-off valve at the condensate outlet is closed – open it. ⇒ Check the electric cabling. ⇒ The dew point is too low – the condensate is frozen – see the corresponding point. ⇒ The BEKOMAT condensate drain does not work properly (see BEKOMAT MANUAL).
◆ Malfunction condensate drainage	⇒ Please read the separate BEKOMAT instructions for installation and operation.
◆ Water in the line.	⇒ The dryer does not start – see the corresponding point. ⇒ If installed – untreated air flows pass through the bypass unit – close the bypass. ⇒ The dryer does not drain the condensate – see the corresponding point. ⇒ Dew point too high – see the corresponding point.
◆ If installed: the P _A high pressure switch has triggered.	⇒ Check which of the following reasons is responsible for the triggering: 1. The ambient temperature is too high or the room ventilation insufficient – ensure sufficient ventilation (air-cooled).

	<ul style="list-style-type: none"> 2. The condenser is dirty – please clean it (air-cooled). 3. The condenser fan does not work – see the corresponding point (air-cooled). 4. The cooling water is too hot – re-establish the nominal conditions (water-cooled). 5. The cooling-water flow is insufficient – re-establish the nominal conditions (water-cooled).
	<ul style="list-style-type: none"> ⇒ Reset the pressure switch by pressing the button on the controller itself – check the perfect functioning of the dryer. ⇒ The PA pressure switch is defective – contact a BEKO service technician regarding the replacement.
◆ If installed: the P _B low-pressure switch has triggered.	<ul style="list-style-type: none"> ⇒ There is a leak in the refrigeration cycle – please contact a BEKO service technician. ⇒ The pressure switched is automatically reset when the normal conditions have been re-established – check the proper operation of the dryer.
◆ If installed: the T _S safety temperature switch is triggered.	<ul style="list-style-type: none"> ⇒ Check which of the following reasons is responsible for the triggering: <ul style="list-style-type: none"> 6. Excessive thermal load – re-establish the standard operating conditions 7. The inlet air is too hot – re-establish the nominal conditions. 8. The ambient temperature is too high or the room ventilation insufficient – ensure sufficient ventilation. 9. The condenser unit is dirty – please clean it. 10. The fan does not work – see the corresponding point. 11. There is a leak in the refrigeration cycle – please contact a BEKO service technician. ⇒ Reset the temperature switch by pressing the button on the temperature switch itself – check the perfect functioning of the dryer. ⇒ The TS temperature switch is defective – replace it.
◆ DMC14 The  LED of the device is on or flashes to indicate alarm situations.	<ul style="list-style-type: none"> ⇒ The  LED flashes because the dew point is too high – see the corresponding point. ⇒ The  LED flashes because dew point is too low – see the corresponding point. ⇒ The  LED flashes because the sensor is defective or fails, the device indicates the message "PF" (sensor failure), replace the sensor.

13.3 Recommended spare parts

NOTE: To order the recommended spare parts or other elements, the data on the type plate must be indicated.

NO.	DESCRIPTION OF THE SPARE PARTS	CODE	DRYPOINT RA 3-40							
			3	5	8	12	18	23	30	40
5	Fan pressure switch PV	XE RA 5655 NNN 170	1	1	1	1	1	1	1	1
6	Compressor	XE RA 5015 110 101	1							
6	Compressor	XE RA 5015 110 104		1						
6	Compressor	XE RA 5015 110 107			1					
6	Compressor	XE RA 5015 110 113				1				
6	Compressor	XE RA 5015 110 115					1			
6	Compressor	XE RA 5015 110 016						1		
6	Compressor	XE RA 5025 116 105							1	
6	Compressor	XE RA 5025 116 010								1
7	Hot gas bypass valve	XE RA 6414 OSS 150	1	1	1	1	1	1		
7	Hot gas bypass valve	XE RA 6414 OSS 155							1	1
9.1	Fan motor	XE RA 5210 110 005	1	1						
9.1	Fan motor	XE RA 5210 110 011			1	1	1	1		
9.1	Fan motor	XE RA 5210 110 018							1	1
9.2	Fan blade	XE RA 5215 000 010	1	1						
9.2	Fan blade	XE RA 5215 000 019			1	1	1	1		
9.2	Fan blade	XE RA 5215 000 025							1	1
9.3	Fan guard	XE RA 5225 000 010			1	1	1	1		
9.3	Fan guard	XE RA 5225 000 027							1	1
10	Filter dryer	XE RA 6650 SSS 007	1	1	1	1	1	1		
10	Filter dryer	XE RA 6650 SSN 150							1	1
12	Dew point sensor T1 - DMC14	XE RA 5625 NNN 035	1♦	1♦	1♦	1♦	1♦	1♦	1♦	1♦
17	DMC14 controller	XE RA 5620 110 103	1♦	1♦	1♦	1♦	1♦	1♦	1♦	1♦
21	BEKOMAT 31	BM31 BI (supply voltage)	1	1	1	1	1	1	1	1
22	Main switch	XE RA 5450 SZN 010	1	1	1	1	1	1	1	1

NO.	DESCRIPTION OF THE SPARE PARTS	CODE	DRYPOINT RA 55-160							
			55	60	80	100	120	140	160	
2	Refrigerant pressure switch PB	XE RA 5655 NNN 085			1	1	1	1	1	1
3	TS safety temperature switch	XE RA 5614 1NN 005	1	1	1	1	1	1	1	1
4	Refrigerant pressure switch PA	XE RA 5655 NNN 087			1	1	1	1	1	1
5	Fan pressure switch PV	XE RA 5655 NNN 170	1	1	1	1	1	1	1	1
6	Compressor	XE RA 5030 116 010	1							
6	Compressor	XE RA 5030 116 015		1						
6	Compressor	XE RA 5030 116 020			1	1				
6	Compressor	XE RA 5030 116 025					1			
6	Compressor	XE RA 5030 116 030							1	
6	Compressor	XE RA 5030 116 035								1
7	Hot gas bypass valve	XE RA 6414 OSS 155	1	1	1	1	1	1	1	1
9	Complete fan	XE RA 5250 110 071			1	1	1			
9	Complete fan	XE RA 5250 110 080							1	1
9.1	Fan motor	XE RA 5210 110 022	1	1						
9.2	Fan blade	XE RA 5215 000 034	1	1						
9.3	Fan guard	XE RA 5225 000 030	1	1						
10	Filter dryer	XE RA 6650 SSN 160	1	1	1	1	1	1	1	1
12	Dew point probe T1 - DMC14	XE RA 5625 NNN 035	1♦	1♦	1♦	1♦	1♦	1♦	1♦	1♦
17	DMC14 controller	XE RA 5620 110 103	1♦	1♦	1♦	1♦	1♦	1♦	1♦	1♦
21	BEKOMAT 31	BM31 BI (supply voltage)	1	1	1	1				
21	BEKOMAT 32 Vario	BM32 V BI (supply voltage)					1	1	1	
22	Main switch	XE RA 5450 SZN 117	1	1	1	1	1	1	1	1

♦ Suggested spare part.

13.4 Maintenance works at the refrigeration cycle



Caution! Refrigerant!

Maintenance and repair works at refrigeration system must only be carried out by BEKO service technicians in accordance with the local provisions.

The total amount of refrigerant in the system must be collected for recycling purposes, resource recovery or disposal.

The refrigerant must not be discharged into the environment.

When delivered, the dryer is ready to operate and filled with a refrigerant of the R134a or R404A type.



Should you detect a refrigerant leak, please contact a BEKO service technician. Prior to any intervention, the room needs to be ventilated.

When the refrigeration cycle needs to be refilled, please also contact a BEKO service technician.

You will find the refrigerant type and amount on the type plate of the dryer.

Properties of the refrigerants:

Refrigerant	Chemical formula	TLV	GWP
R134a – H-FKW	CH_2FCF_3	1000 ppm	1300
R404A – H-FKW	$\text{CH}_2\text{FCF}_3/\text{C}_2\text{HF}_5/\text{C}_2\text{H}_3\text{F}_3$	1000 ppm	3784

13.5 Dismantling of the dryer

When the dryer is dismantled, all parts and operating materials related to the plant need to be disposed of separately.



Component	Material
Refrigerant	R404A, R134a, oil
Roof and supports	Structural steel, epoxy paint coat
Refrigerating compressor	Steel, copper, aluminium, oil,
Aluminium heat exchanger	Aluminium
Condenser unit	Aluminium, copper, structural steel
Pipe	Copper
Fan	Aluminium, copper, steel
Valve	Brass, steel
BEKOMAT condensate drain	PVC, aluminium, steel
Insulant	Synthetic rubber without CFCs, polystyrene, polyurethane
Electric cable	Copper, PVC
Electric parts	PVC, copper, brass



We recommend observing the safety provisions in force for the disposal of each material type.

The refrigerant contains lubricating-oil droplets which are released by the compressor.

The refrigerant must not be discharged into the environment. It must be sucked off from the dryer using a suitable device, and then needs to be supplied to a collection point.

14 Appendices

14.1 Dryer dimensions

14.1.1 Dryer dimensions DRYPOINT RA 3-12 /AC

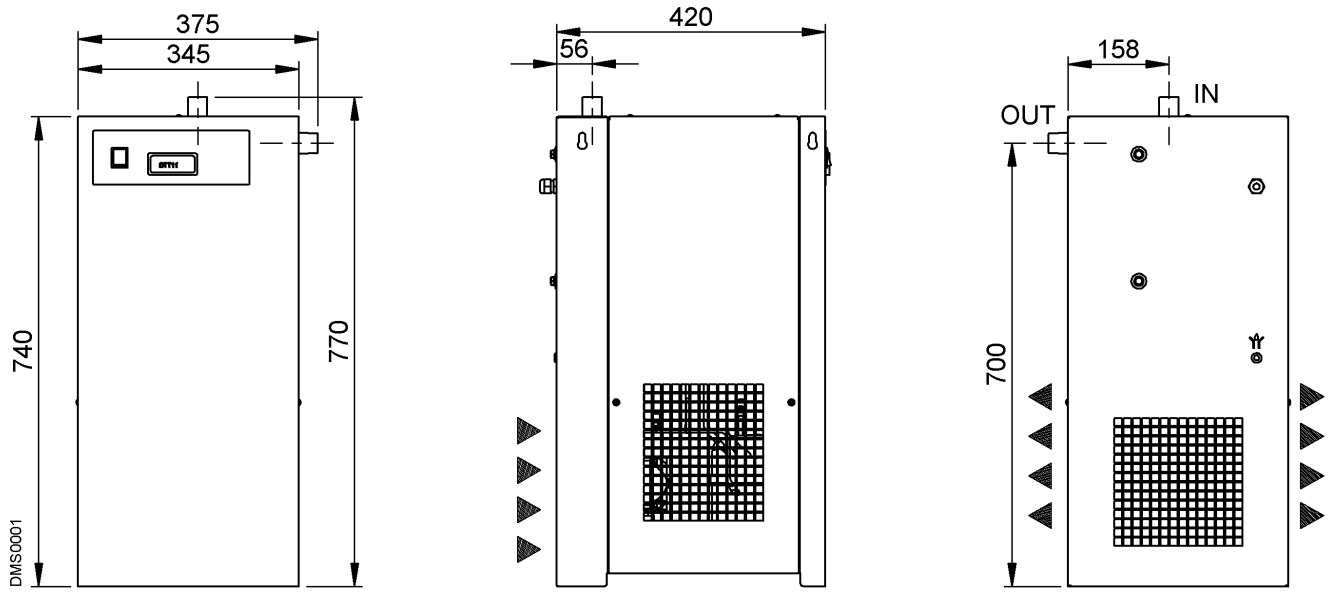

14.1.2 Dryer dimensions DRYPOINT RA 18-23 /AC

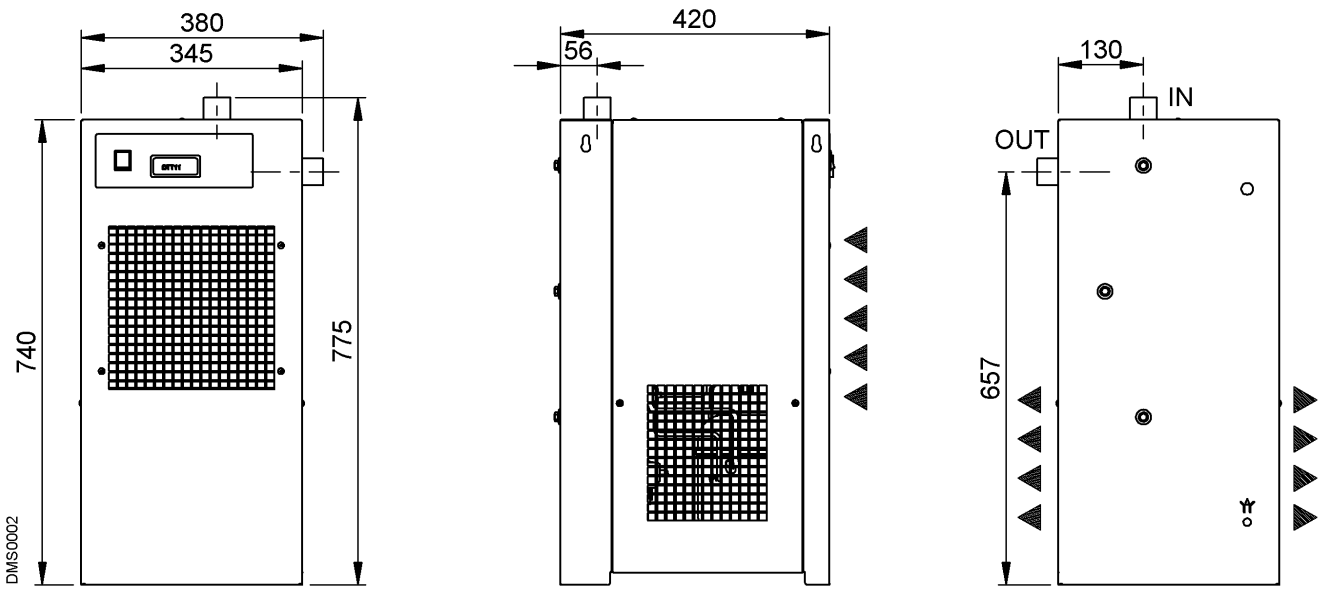

14.1.3 Dryer dimensions DRYPOINT RA 30-40 /AC

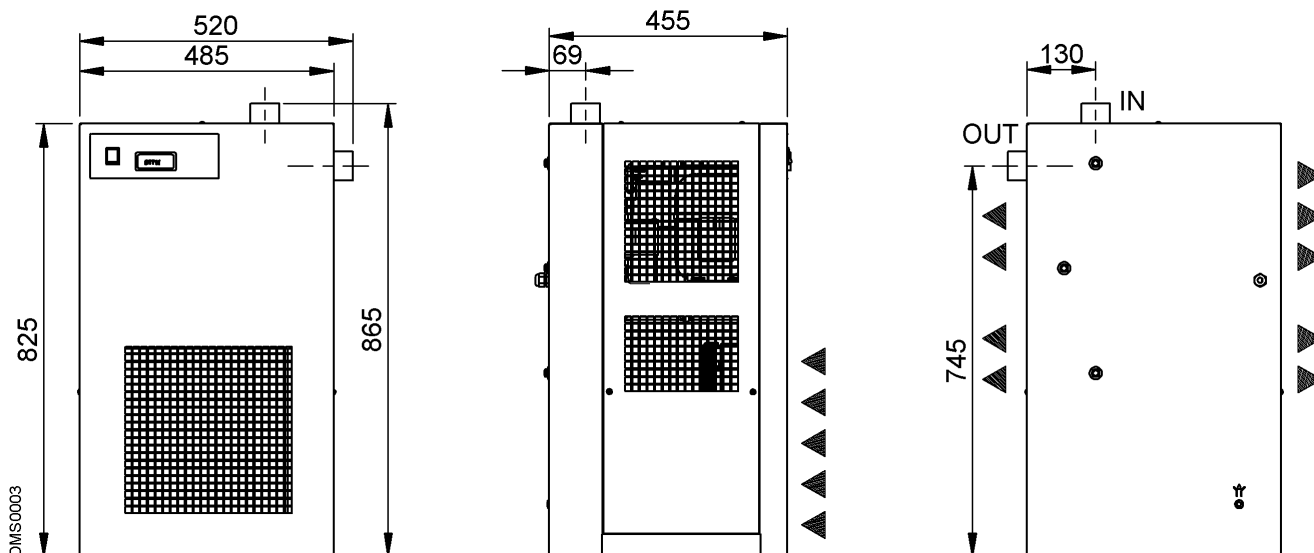

14.1.4 Dryer dimensions DRYPOINT RA 55-60/AC

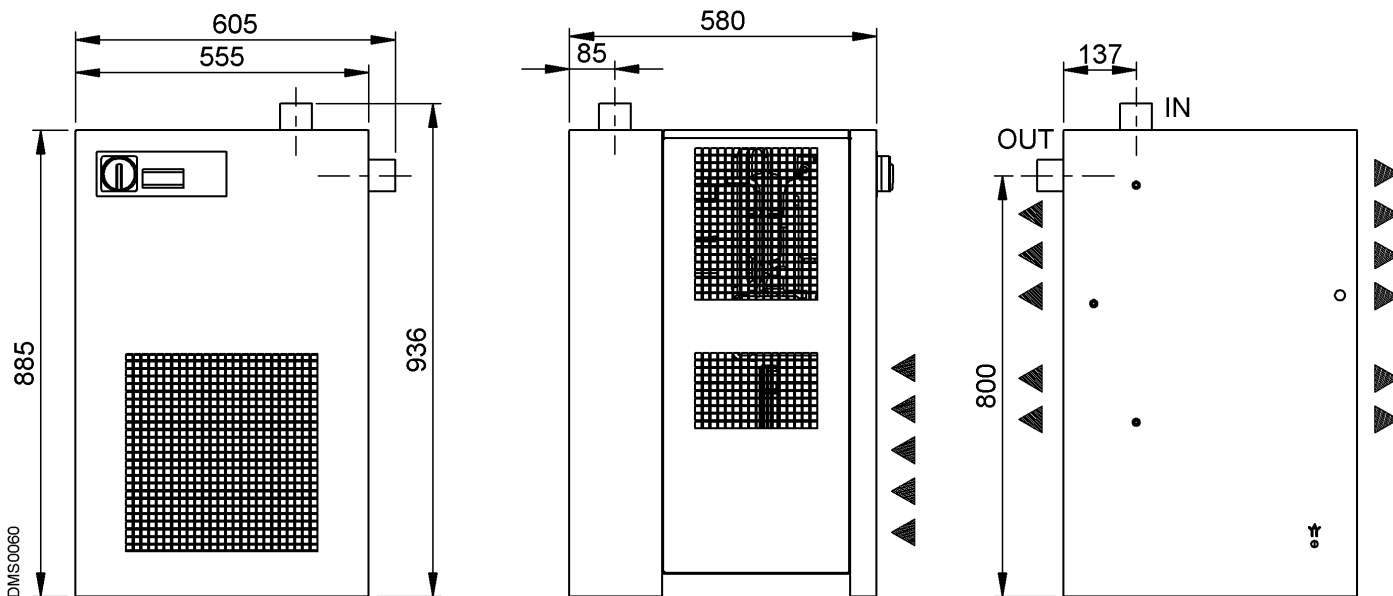

14.1.5 Dryer dimensions DRYPOINT RA 80-100 /AC

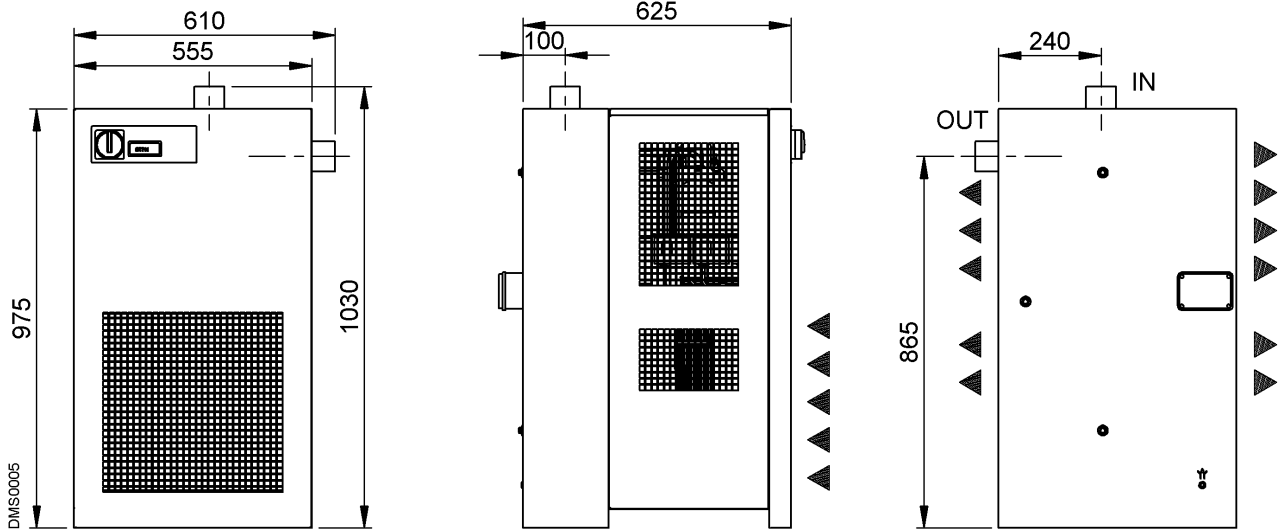

14.1.6

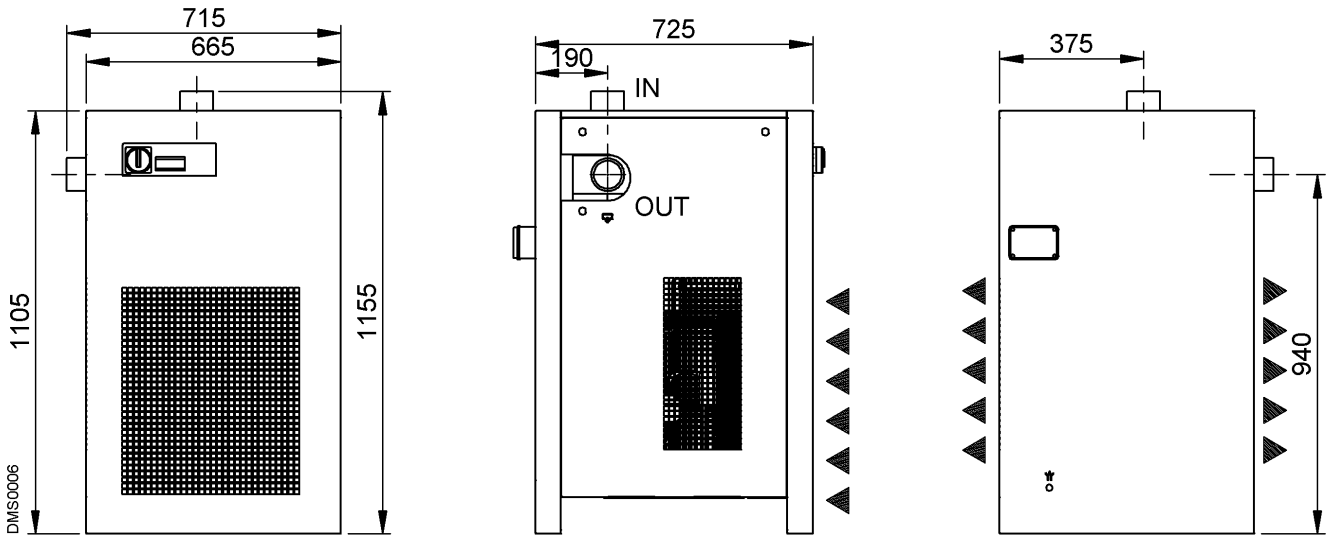

14.1.7 Dryer dimensions DRYPOINT RA 55-60 /WC

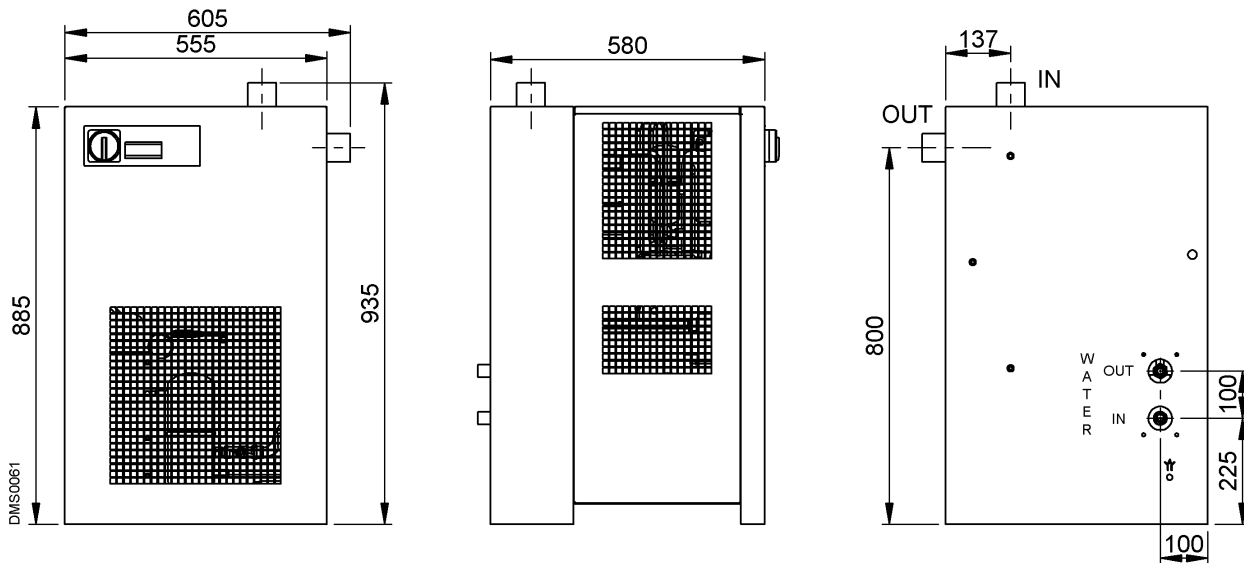

14.1.8 Dryer dimensions DRYPOINT RA 80-100 /WC

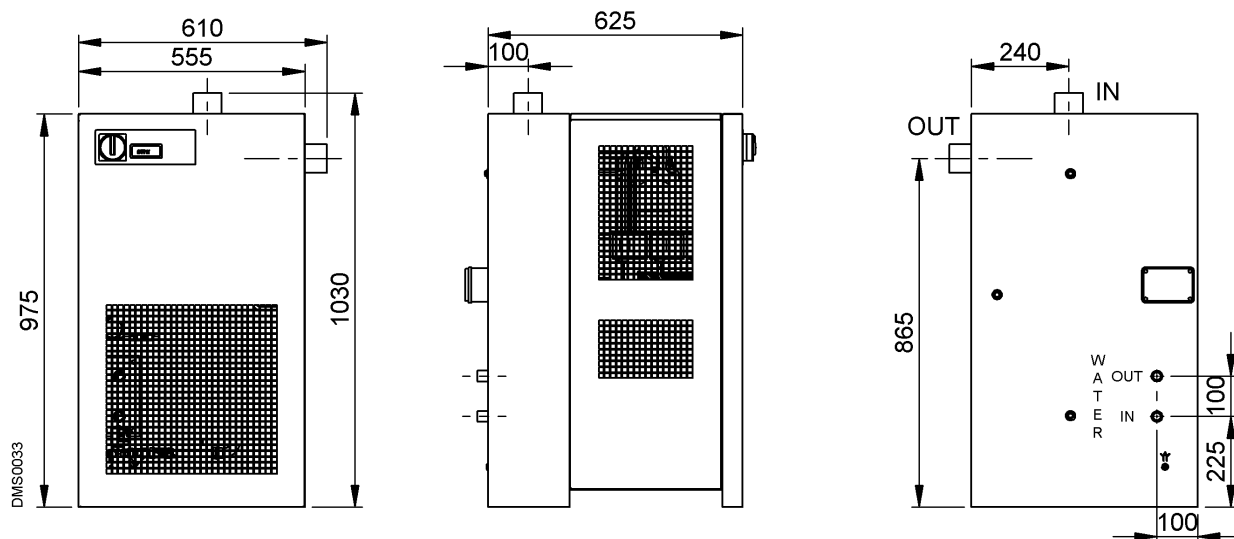

14.1.9 Dryer dimensions DRYPOINT RA 120-160 /WC

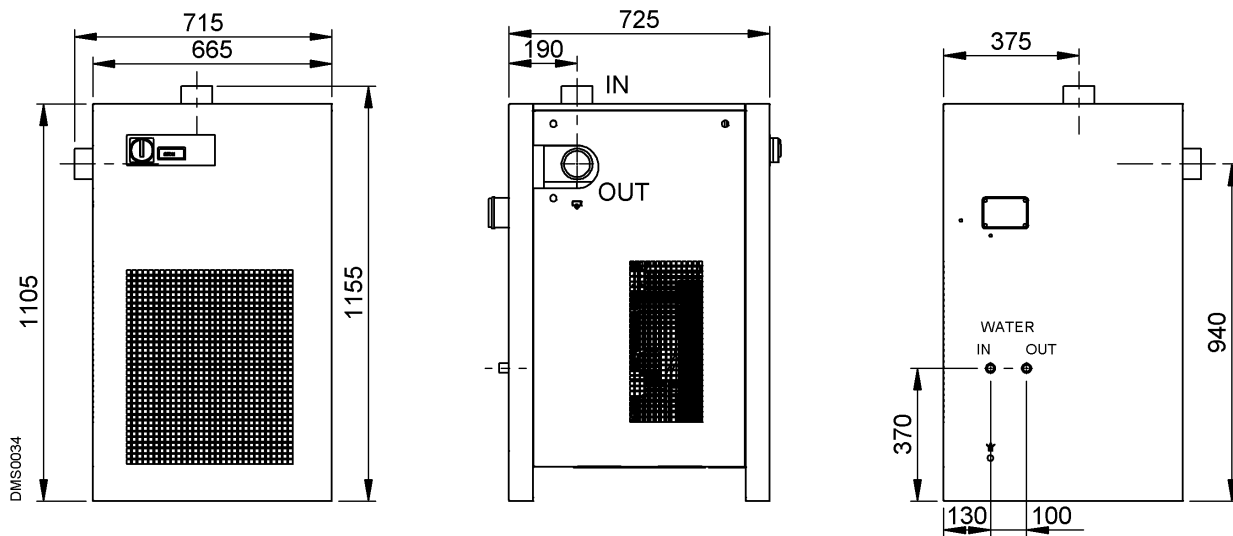

14.2 Exploded diagram**14.2.1 Exploded diagram – diagram of the functional elements**

1	Aluminium heat exchanger	18	Condenser (water-cooled)
1.1	Insulating material	19	Cooling-water regulator (water-cooled)
2	Refrigerant pressure switch P_B (DRYPOINT RA 80-160)	20	Liquid collector (water-cooled)
3	T_S safety temperature switch (DRYPOINT RA 55-160)	21	BEKOMAT condensate drain
4	Refrigerant pressure switch P_A (DRYPOINT RA 80-160)	22	Main switch
5	Refrigerant pressure switch (Ventilator) P_V	...	
6	Refrigerating compressor	51	Front panel
7	Hot gas bypass valve	52	Back plate
8	Condenser (air-cooled)	53	Right side panel
9	Condenser fan	54	Left side panel
9.1	Motor	55	Cover
9.2	Blades	56	Base plate
9.3	Grid	57	Upper plate
10	Filter dryer	58	Carrier support
11	Capillary tube	59	Bracket
12	T1 Temperature sensor (dew point)	60	Control panel
13	Condensate drain service valve	61	Electric plug
17	Electronic control unit	62	Electric cabinet

14.2.2 Exploded diagram DRYPOINT RA 3-12

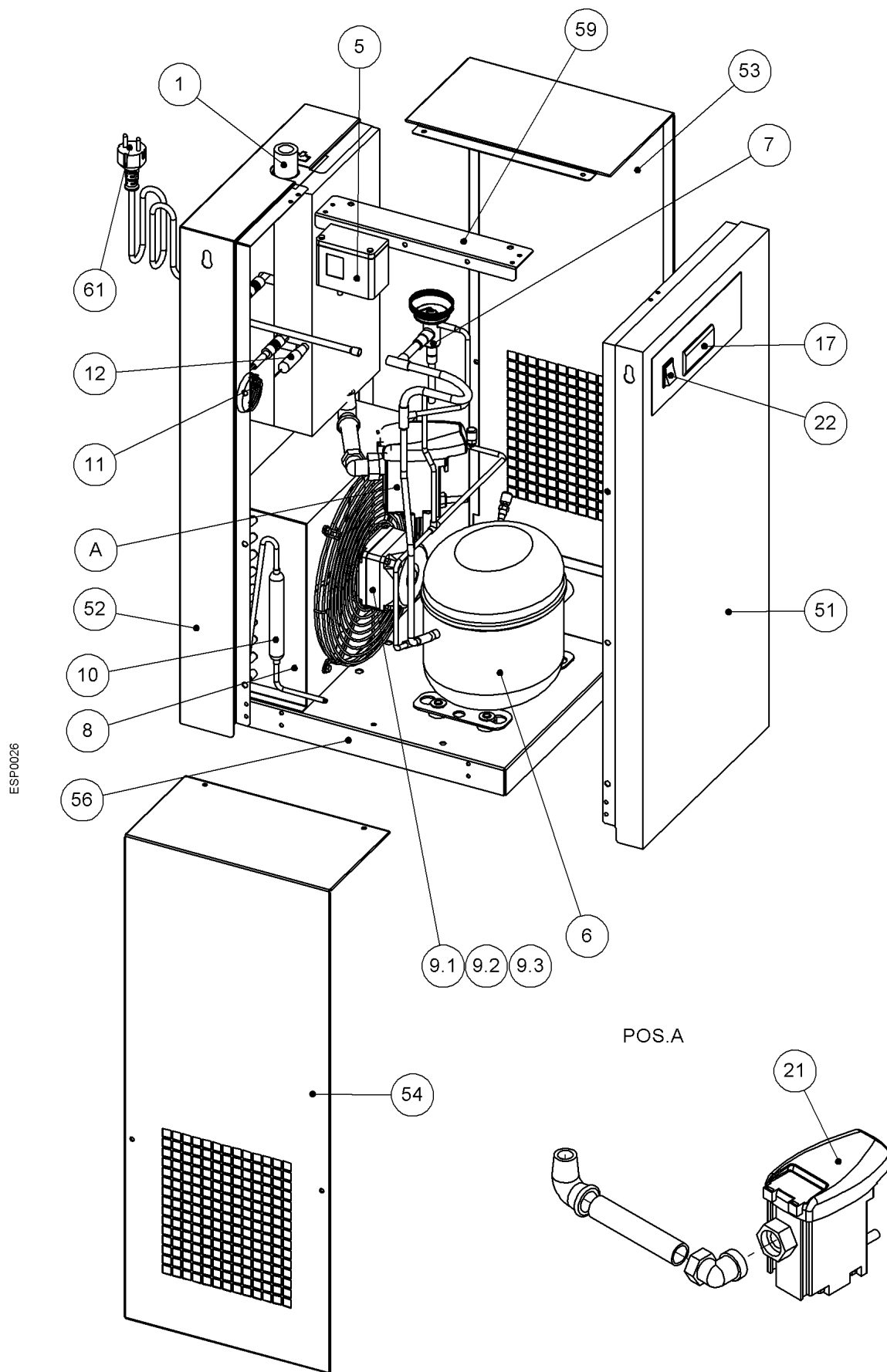

14.2.3 Exploded diagram DRYPOINT RA 18-23

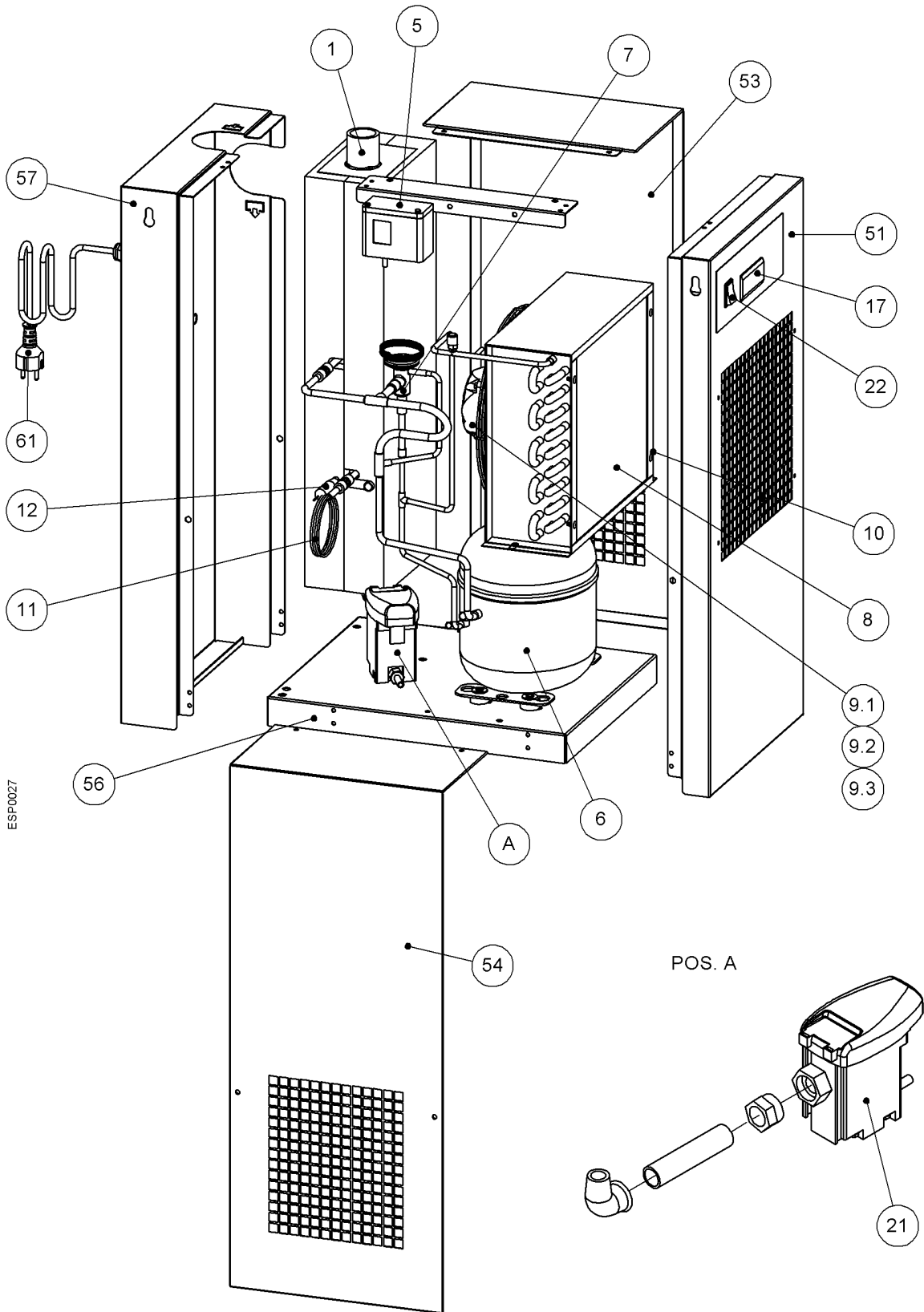

14.2.4 Exploded diagram DRYPOINT RA 30-40

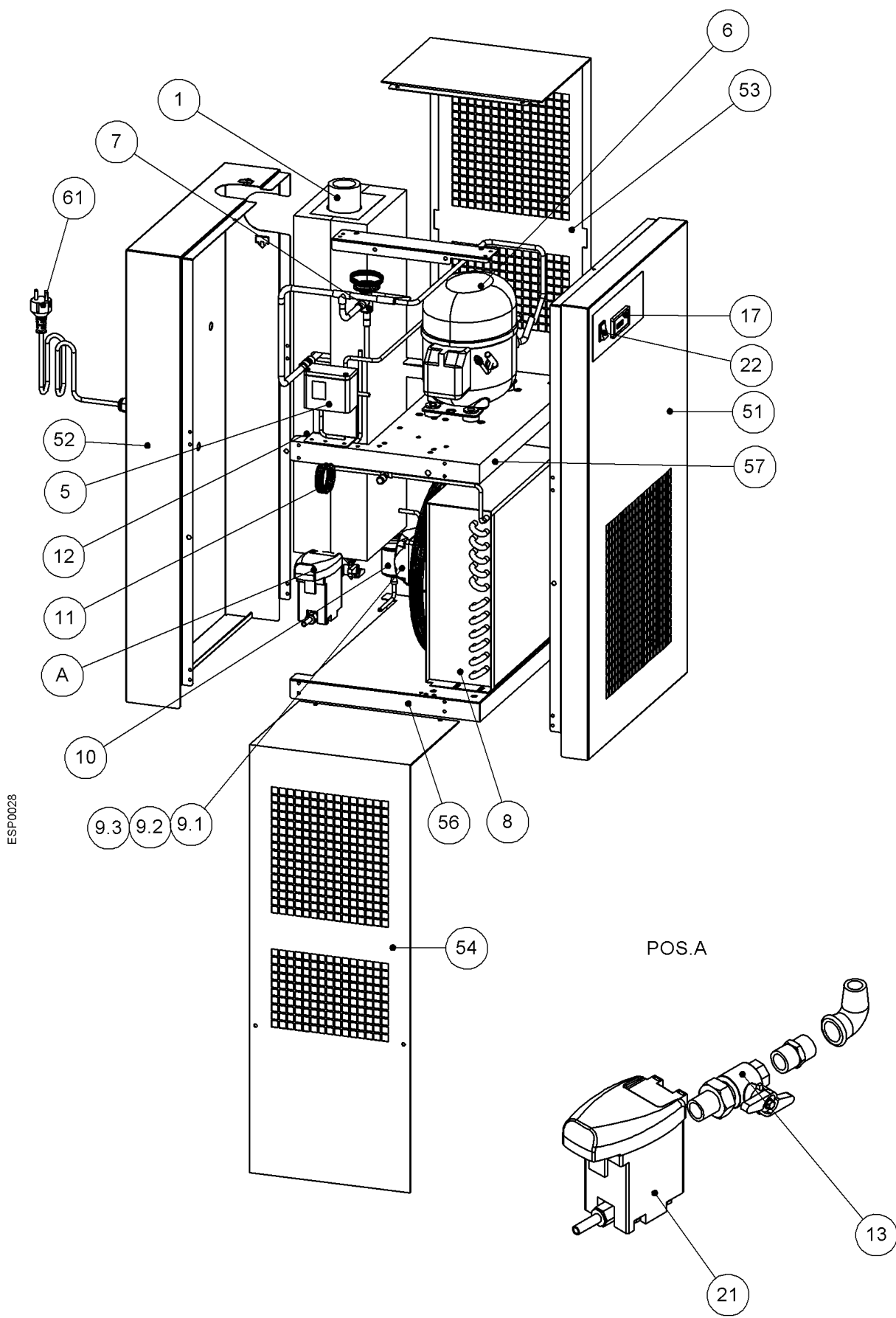

ESP0028

14.2.5 Exploded diagram DRYPOINT RA 55-60

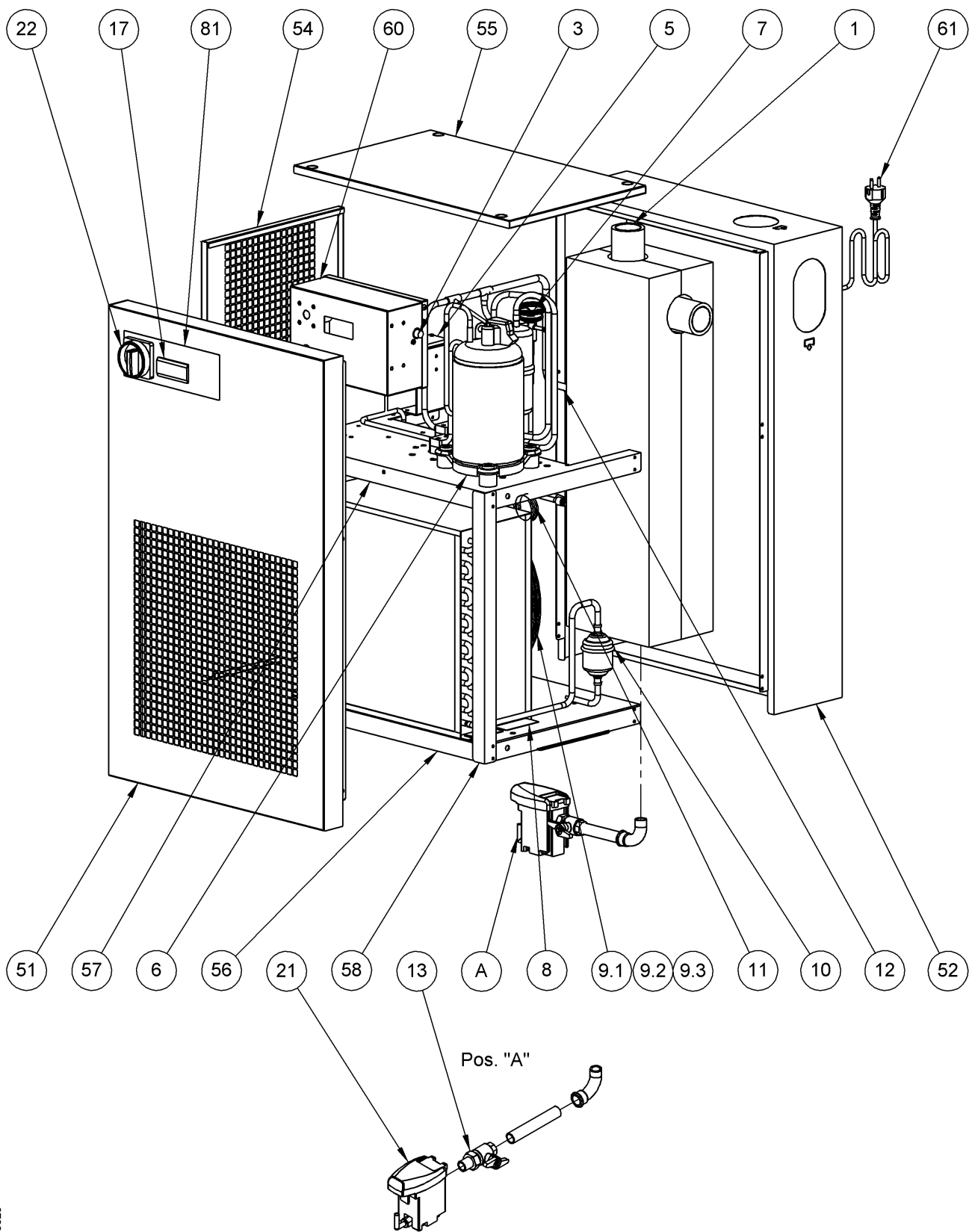

ESP0029

14.2.6 Exploded diagram DRYPOINT RA 80-100

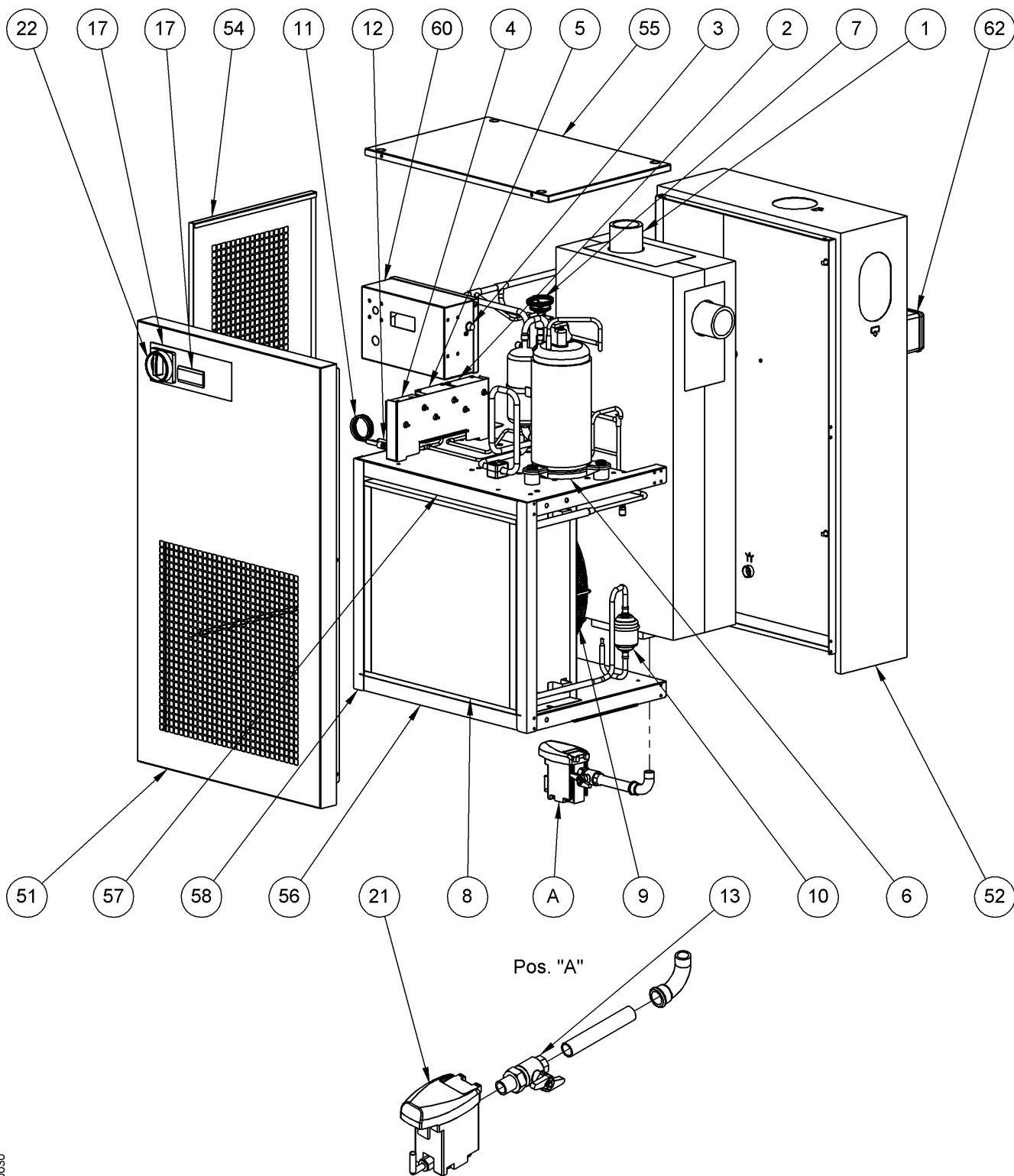

ESP0030

14.3 Circuit diagrams

14.3.1 Circuit diagram – diagram of the functional elements

- IG** : Main switch
- K** : Refrigerating compressor
 - KT** : Compressor thermal insulation
 - KR** : Compressor starting relay (if installed)
 - CS** : Compressor starting capacitor (if installed)
 - CR** : Compressor operating capacitor (if installed)
- V** : Condenser fan
 - CV** : Fan starting capacitor (if installed)
- DMC14** : DMC14 Electronic controller compressed-air dryer
- PR** : T1 Temperature sensor (dew point)
- PV** : Pressure switch – fan control
- PA** : Pressure switch– compressor pressure side – high pressure (DRYPOINT RA 80-160)
- PB** : Pressure switch– compressor suction side - low pressure (DRYPOINT RA 80-160)
- TS** : T_S safety temperature switch (DRYPOINT RA 55-160)
- BOX** : Electric cabinet
- ELD** : BEKOMAT condensate drain

- BN = BROWN
- BU = BLUE
- BK = BLACK
- YG = YELLOW/GREEN

14.3.2 Circuit diagram DRYPOINT RA 3-40

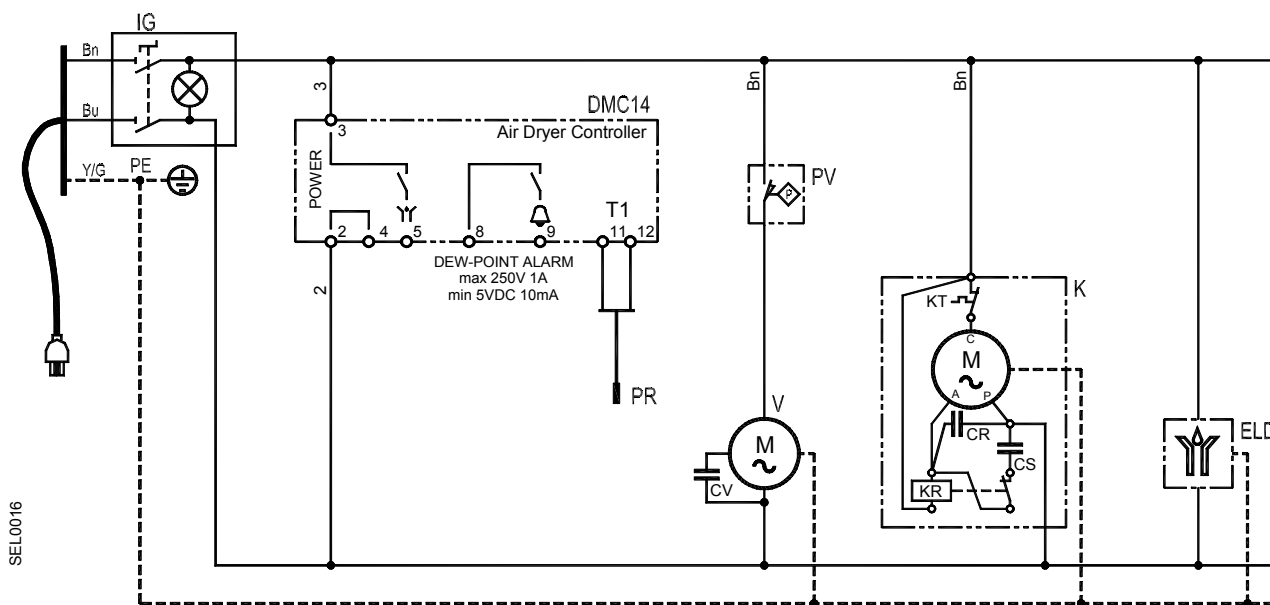

Air Dryer Controller
DEW-POINT ALARM

14.3.3 Circuit diagram DRYPOINT RA 55-60

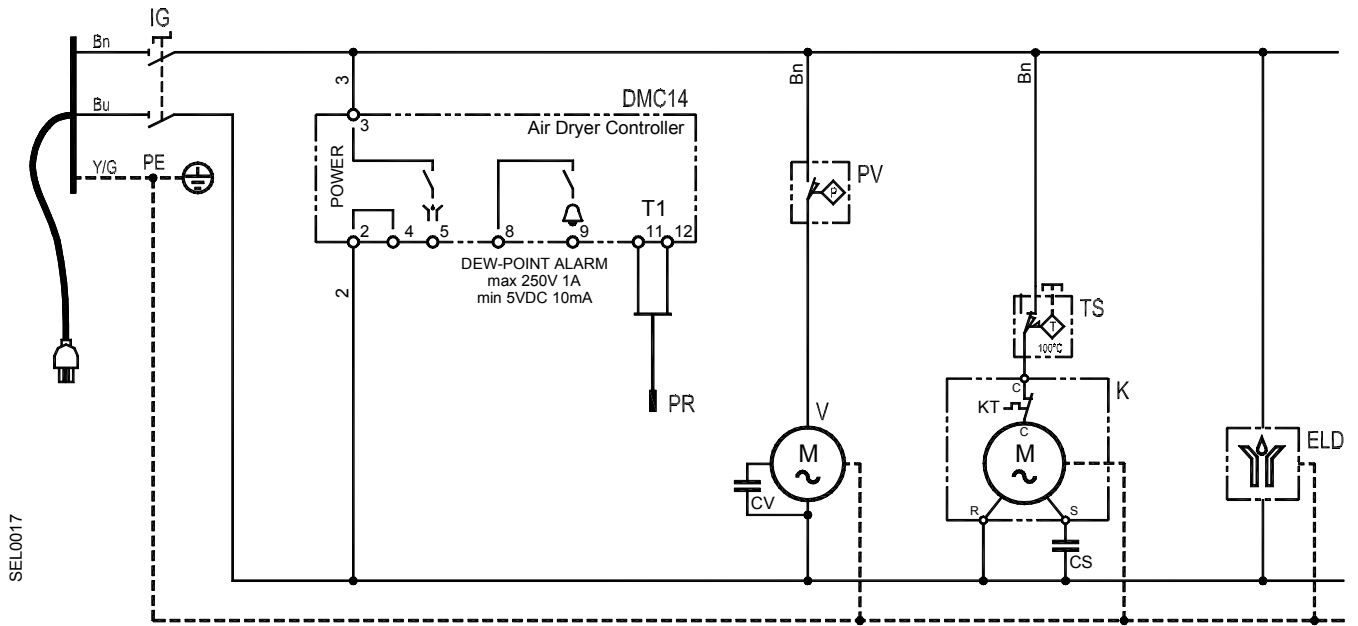

SEL0017

Air Dryer Controller
DEW-POINT ALARM

14.3.4 Circuit diagram DRYPOINT RA 80-160

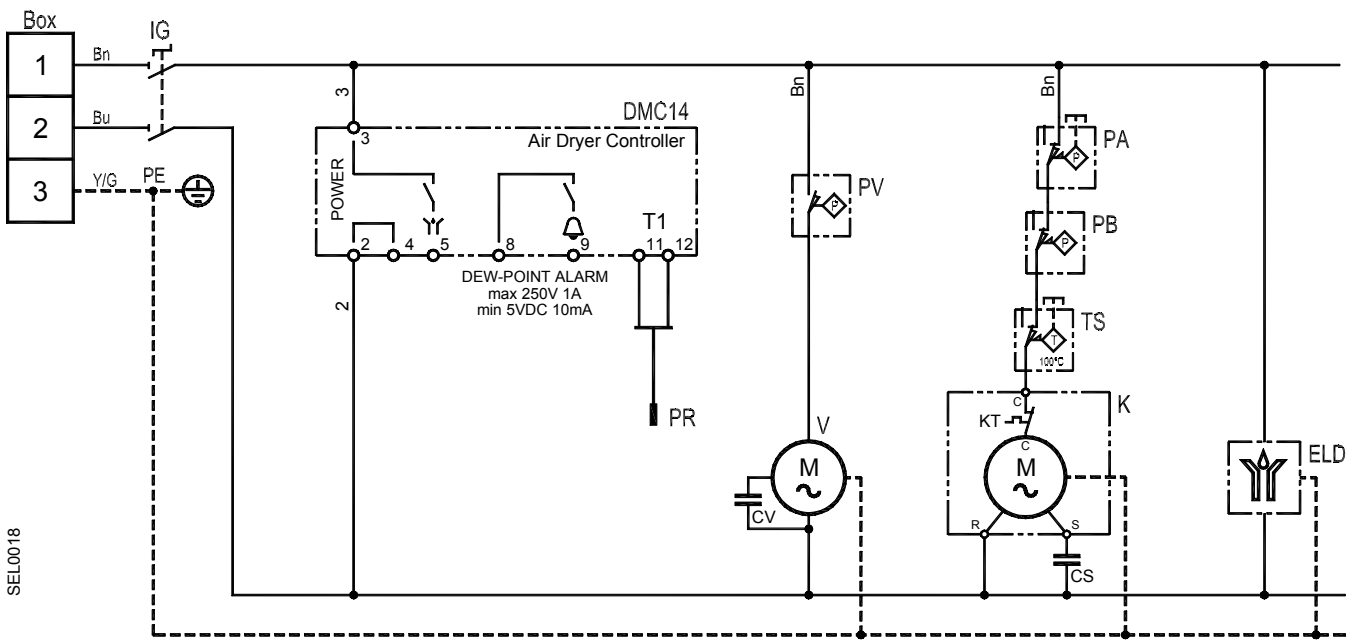

SEL0018

Air Dryer Controller
DEW-POINT ALARM

A		
Aluminium heat exchanger	26	
Appendices	36	
B		
BEKOMAT	29	
C		
Calculation of the air throughput.....	14	
Capillary tube	26	
Certified skilled personnel.....	7	
Certified skilled personnel.....	31	
Circuit diagram DRYPOINT RA 3-40.....	47	
Circuit diagram DRYPOINT RA 55-60.....	48	
Circuit diagram DRYPOINT RA 80-160.....	48	
Circuit diagrams	47	
Condensate drain.....	16	
Condenser	25	
Connection to the compressed-air system	15	
Connection to the cooling-water network (water-cooled)	15	
Contaminated intake air	13	
Control panel.....	23	
Cooling-water controller	25	
Correction factors.....	14	
D		
Danger compressed air.....	7, 8	
Danger compressed air.....	30	
Danger compressed air.....	30	
Danger compressed air.....	31	
Danger compressed air.....	31	
Danger supply voltage	7	
Danger supply voltage	30	
Danger supply voltage	31	
Diagram of the functional elements	40	
Dismantling	30	
Dismantling of the dryer	35	
Dryer dimensions	36	
Dryer dimensions DRYPOINT RA 120-160 /AC	38	
Dryer dimensions DRYPOINT RA 120-160 /WC	39	
Dryer dimensions DRYPOINT RA 18-23 /AC	36	
Dryer dimensions DRYPOINT RA 30-40 /AC	37	
Dryer dimensions DRYPOINT RA 3-12 /AC	36	
Dryer dimensions DRYPOINT RA 55-60 /WC	39	
Dryer dimensions DRYPOINT RA 55-60/AC	37	
Dryer dimensions DRYPOINT RA 80-100 /AC	38	
Dryer dimensions DRYPOINT RA 80-100 /WC	39	
E		
Electrical connections	16	
Exclusion from a field of application	10	
Exclusion of an application	10	
Exploded diagram	40	
Exploded diagram DRYPOINT RA 80-100	45	
Exploded diagram DRYPOINT RA 120-160	46	
Exploded diagram DRYPOINT RA 18-23	42	
Exploded diagram DRYPOINT RA 30-40	43	
Exploded diagram DRYPOINT RA 3-12	41	
Exploded diagram DRYPOINT RA 55-60	44	
F		
Field of application	10	
Filter dryer	26	
Flow diagram	24	
Functional description	23	
H		
Hot gas bypass valve.....	26	
I		
Initial start-up	18	
Installation	12	
Installation plan	13	
Instructions, safety instructions.....	5	
M		
Maintenance	30	
Maintenance works at the refrigeration cycle	35	
Minimum installation requirements	12	
O		
Overview of the safety instructions	7	
P		
Place of installation	12	
Pressure Equipment Directive	10	
Proper use	10	
R		
Recommended spare parts	34	
Refrigerant pressure switches	27	
Refrigerating compressor	25	
Removal from service	19	
Restart	19	
S		
Safety instructions.....	5, 7	
Safety pictograms in accordance with DIN 4844	6	
Safety temperature switch	27	
Spare parts	30, 34	
Start-up	17	
Storage	11	
T		
Technical data.....	20	
Technical data DRYPOINT RA 3-60 /AC.....	20	
Technical data DRYPOINT RA 80-160 /AC	21	
Technical description	23	
Technische Daten DRYPOINT RA 55-160 /WC	22	
Transport.....	11	
Troubleshooting	30	
Type plate	5	
U		
Unauthorised intervention	9	

Original operating instructions in German.
Subject to technical changes / errors excepted.
DRYPOINT RA 3-160_manual_en_2010_10