

EN - english

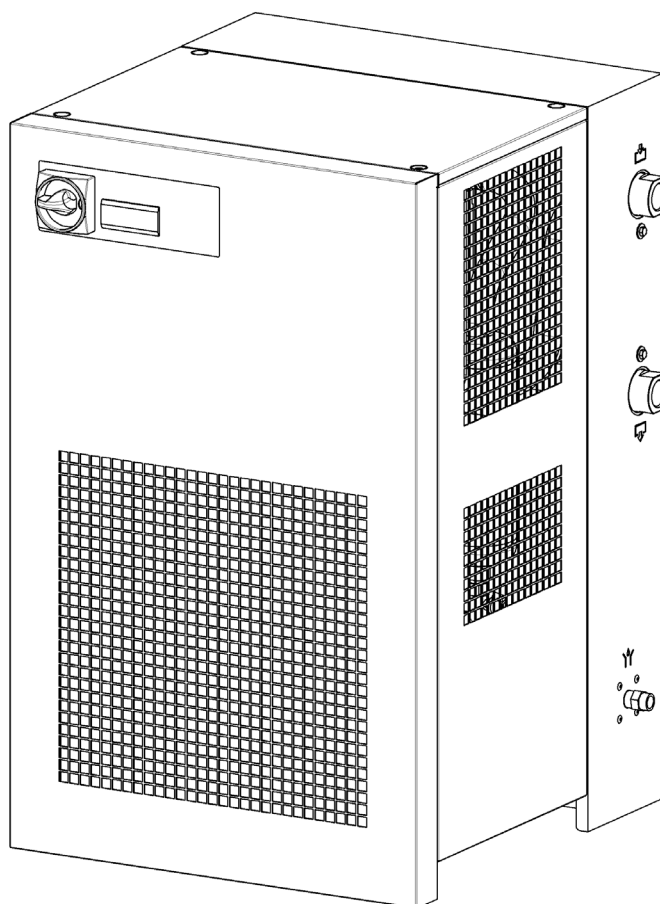

## Instructions for installation and operation

# High pressure compressed air refrigeration dryer DRYPOINT® RS 25-1010 HP50



05-023  
00\_00

---

Dear customer,

Thank you for deciding in favour of the DRYPOINT® RS 25-1010 HP50 high pressure compressed-air refrigeration dryer. Please read these installation and operating instructions carefully before mounting and starting up the DRYPOINT® RS 25-1010 HP50 and follow our directions. Perfect functioning of the DRYPOINT® RS 25-1010 HP50 and thus reliable compressed-air drying can only be guaranteed when the provisions and notes stipulated here are strictly adhered to.

---

## Contents

1	Name plate	6
2	Safety instructions	6
2.1	Safety pictograms in accordance with DIN 4844	7
2.2	Signal words in accordance with ANSI	9
2.3	Overview of the safety instructions	9
3	Proper use	13
4	Exclusion from a field of application	13
5	Operating instructions in accordance with the 2014/68/EU Pressure Equipment Directive	14
6	Transport	15
7	Storage	15
8	Installation	16
8.1	Place of installation	16
8.2	Installation plan	17
8.3	Correction factors	18
8.4	Connection to the compressed-air system	19
8.5	Connection to the cooling-water network	19
8.6	Minimum cooling water requirements:	20
8.7	Electrical connections	21
8.8	Condensate drain	21
9	Start-up	22
9.1	Preliminary stages	22
9.2	Initial start-up	22
9.3	Shut down and restart	23
10	Technical data	25
10.1	Technical data DRYPOINT RS 25-90 HP50 1/230/50-60	25
10.2	Technical data DRYPOINT RS 135-1010 HP50 1/230/50	26
10.3	Technical data DRYPOINT RS 320-1010 HP50 3/400/50	27
10.4	Technical data DRYPOINT RS 25-320 HP50 1/115/60	28
10.5	Technical data DRYPOINT RS 90-1010 HP50 1/230/60	29
10.6	Technical data DRYPOINT RS 320-1010 HP50 3/460/60	30
11	Technical description	31
11.1	Control panel	31
11.2	Functional description	31
11.3	Flow chart (air-cooled)	32
11.4	Flow chart (water-cooled)	32
11.5	Refrigerating compressor	34
11.6	Condenser (air-cooled)	34
11.7	Condenser (water-cooled)	34
11.8	Cooling-water regulating valve	34
11.9	Filter dryer	34
11.10	Capillary tube	34
11.11	Air-to-air heat exchanger	34
11.12	Air-to-refrigerant heat exchanger	35

11.13	Condensate separator	36
11.14	Hot-gas bypass valve	36
11.15	Refrigerant pressure switches LPS – HPS	36
11.16	Safety temperature switch TS	36
11.17	Compressor crankcase heater	36
11.18	DMC 35 electronics (control unit compressed-air dryer) – RS 25-70	38
11.18.1	How to switch on the dryer	38
11.18.2	How to switch off the dryer	38
11.18.3	How a service warning / alarm is displayed	38
11.18.4	How is controlled the condenser fan	39
11.18.5	How is controlled the drain solenoid valve	40
11.18.6	How to display the total hours of operation	40
11.18.7	How to change the operating parameters	40
11.19	DMC 34 electronics (control unit compressed-air dryer)	41
11.19.1	How to switch on the dryer	41
11.19.2	How to switch off the dryer	41
11.19.3	How to display the operating parameters	41
11.19.4	How a service warning / alarm is displayed	42
11.19.5	How is controlled the condenser fan	42
11.19.6	How is controlled the drain solenoid valve	42
11.19.7	How to reset the service reminder timer	42
11.19.8	Operation of the failure / alarm dry contact	42
11.19.9	How to change the operating parameters	44
11.20	Electronically level-controlled BEKOMAT condensate drain	45
12	Maintenance, troubleshooting, spare parts and dismantling	46
12.1	Checks and maintenance	46
12.2	Troubleshooting	47
12.3	Recommended spare parts	52
12.4	Maintenance works at the refrigeration cycle	54
12.5	Dismantling the dryer	54
13	Appendices	56
13.1	Dryer dimensions	56
13.1.1	Dryer dimensions DRYPOINT RS 25-70 HP50	57
13.1.2	Dryer dimensions DRYPOINT RS 90-135 HP50	58
13.1.3	Dryer dimensions DRYPOINT RS 180-240 HP50	60
13.1.4	Dryer dimensions DRYPOINT RS 320-620 HP50	62
13.1.5	Dryer dimensions DRYPOINT RS 810-1010 HP50	64
13.1.6	Dryer dimensions DRYPOINT RS 320-620 HP50 3phase	66
13.1.7	Dryer dimensions DRYPOINT RS 810-1010 HP50 3phase	68
13.2	Exploded diagrams	70
13.2.1	Components of the exploded diagrams	70
13.2.2	Exploded diagram DRYPOINT RS 25-70 HP50 / AC	71
13.2.3	Exploded diagram DRYPOINT RS 90-135 HP50 / AC	72
13.2.4	Exploded diagram DRYPOINT RS 180-240 HP50 / AC	73
13.2.5	Exploded diagram DRYPOINT RS 320-620 HP50 / AC	74
13.2.6	Exploded diagram DRYPOINT RS 810-1010 HP50 / AC	75
13.2.7	Exploded diagram DRYPOINT RS 320-620 HP50 / WC	76
13.2.8	Exploded diagram DRYPOINT RS 810-1010 HP50 / WC	77
13.2.9	Exploded diagram DRYPOINT RS 320-620 HP50 3phase / AC	78
13.2.10	Exploded diagram DRYPOINT RS 810-1010 HP50 3phase / AC	79

---

13.2.11	Exploded diagram DRYPOINT RS 320-620 HP50 3phase / WC	80
13.2.12	Exploded diagram DRYPOINT RS 810-1010 HP50 3phase / WC	81
13.3	Electric diagrams	82
13.3.1	Electric diagrams – list of components	82
13.3.2	Electric diagram DRYPOINT RS 25-70 HP50	83
13.3.3	Electric diagram DRYPOINT RS 90-135 HP50	84
13.3.4	Electric diagram DRYPOINT RS 180-240 HP50	86
13.3.5	Electric diagram DRYPOINT RS 320-450 HP50	88
13.3.6	Electric diagram DRYPOINT RS 620 HP50	90
13.3.7	Electric diagram DRYPOINT RS 810-1010 HP50	92
13.3.8	Electric diagram DRYPOINT RS 320-1010 HP50 3phase Sheet 1/3	93
13.3.9	Electric diagram DRYPOINT RS 320-1010 HP50 3phase Sheet 2/3	95
13.3.10	Electric diagram DRYPOINT RS 320-1010 HP50 3phase Sheet 3/3	97
14	EC Declaration of conformity	100

## 1 Name plate

The name plate is on the back of the dryer and comprises all primary data of the device. Always refer to these when contacting the manufacturer or the sales department.

All guarantee claims will expire in the event that the name plate is modified or removed.

The dryer model printed on the nameplate includes one or more suffixes that specify one or more features of dryer.

Explanation of 1st suffix for power supply requirements :

1st SUFFIX	DESCRIPTION OF FEATURE
none	1/230/50
-C	3/400/50
-P	1/115/60
-E	1/230/60
-R	3/460/60
-S	3/230/60 (with internal autotransformer)
-F	3/380/60 (with internal autotransformer)
-T	3/690/60 (with internal autotransformer)

Explanation of 2nd suffix for cooling requirements :

2nd SUFFIX	DESCRIPTION OF FEATURE
/ AC	Air cooled
/ WC	Fresh water cooled
/ SWC	Sea water cooled, tube bundle condenser
/ TBH	Fresh water cooled, tube bundle condenser

Explanation of (eventual) 3rd suffix for special features :

3rd SUFFIX	DESCRIPTION OF FEATURE
-TAC	Anti corrosion treatment
-SP	Special feature
-OF	Dryer oil free

Examples : DP RS620-R HP50 /AC → DP RS620 HP50 3/460/60, Air cooled  
 DP RS450-C HP50 /WC → DP RS450 HP50 3/400/50, Water cooled  
 DP RS450 HP50 /WC -TAC → DP RS450 HP50 1/230/50, Water cooled, Anti corrosion treatment

## 2 Safety instructions



### Please check whether or not these instructions correspond to the device type.

Please adhere to all advice given in these operating instructions. They include essential information which must be observed during installation, operation and maintenance. Therefore, it must be ensured that these operating instructions are read by the fitter and the responsible operator / certified skilled personnel prior to installation, start-up and maintenance.

The operating instructions must be accessible at all times at the place of application of the DRYPOINT® RS 25-1010 HP50 high pressure compressed-air refrigeration dryer.

In addition to these operating instructions, local and national regulations need to be observed, where required .

Ensure that operation of the DRYPOINT® RS 25-1010 HP50 high pressure compressed-air refrigeration dryer only takes place within the permissible limit values indicated on the name plate. Any deviation from these limit values involves a risk for persons and for the material, and may result in malfunction or a breakdown.

After installing the device correctly and in accordance with the instructions in this manual, the dryer is ready to operate, further settings are not required. Operation is fully automatic and maintenance is limited to several examinations and cleaning measures which are described in the following chapters.

This manual must be available at all times for future reference and is a constituent part of the dryer.

If you have any queries regarding these installation and operating instructions, please contact BEKO TECHNOLOGIES GMBH.

2.1 Safety pictograms in accordance with DIN 4844



Observe operating instructions



General danger symbol



Supply voltage



Danger: component or system under pressure



Hot surfaces



Non-breathable air



Do not use water to extinguish the fire



Do not operate with open cover (housing)



Maintenance works or controlling measures must only be carried out by qualified personnel<sup>1</sup>



Do not smoke



Note



Connection point compressed-air inlet



Connection point compressed-air outlet



Connection point condensate drain

<sup>1</sup> Certified skilled personnel are persons who are authorised by the manufacturer, with experience and technical training, who are well-grounded in the respective provisions and laws and capable of carrying out the required works and of identifying and avoiding any risks during the machine transport, installation, operation and maintenance. Qualified and authorised operators are persons who are instructed by the manufacturer regarding the handling of the refrigeration system, with experience and technical training, and who are well-grounded in the respective provisions and laws.

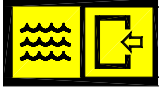

Connection point cooling-water inlet (water-cooled)



Connection point cooling-water outlet (water-cooled)



Works can be carried out by the operator of the plant, provided that they are skilled accordingly<sup>2</sup>.

**NOTE:** Text that contains important specifications to be considered – does not refer to safety precautions.



The device was carefully designed with particular attention paid to environmental protection:

- CFC-free refrigerants
- CFC-free insulation material
- Energy-saving design
- Limited acoustic emissions
- Dryer and packaging comprise reusable materials

This symbol advises the user to observe the environmental aspects and comply with the recommendations connected with this symbol.

---

<sup>2</sup> Certified skilled personnel are persons who are authorised by the manufacturer, with experience and technical training, who are well-grounded in the respective provisions and laws and capable of carrying out the required works and of identifying and avoiding any risks during the machine transport, installation, operation and maintenance. Qualified and authorised operators are persons who are instructed by the manufacturer regarding the handling of the refrigeration system, with experience and technical training, and who are well-grounded in the respective provisions and laws.

## 2.2 Signal words in accordance with ANSI

<b>Danger!</b>	Imminent hazard Consequences of non-observance: serious injury or death
<b>Warning!</b>	Potential hazard Consequences of non-observance: possible serious injury or death
<b>Caution!</b>	Imminent hazard Consequences of non-observance: possible injury or property damage
<b>Notice!</b>	Potential hazard Consequences of non-observance: possible injury or property damage
<b>Important!</b>	Additional advice, info, hints Consequences of non-observance: disadvantages during operation and maintenance, no danger

## 2.3 Overview of the safety instructions



### Certified skilled personnel

Installation works must exclusively be carried out by authorised and qualified skilled personnel. Prior to undertaking any measures on the DRYPOINT® RS 25-1010 HP50 high pressure compressed-air refrigeration dryer, the certified skilled personnel shall read up on the device by carefully studying the operating instructions. The operator is responsible for the adherence to these provisions. The respective directives in force apply to the qualification and expertise of the certified skilled personnel. For safe operation, the device must only be installed and operated in accordance with the indications in the operating instructions. In addition, the national and operational statutory provisions and safety regulations, as well as the accident prevention regulations required for the respective case of application, need to be observed during employment. This applies accordingly when accessories are used.



### Danger!

#### Compressed air!

**Risk of serious injury or death through contact with quickly or suddenly escaping compressed air or through bursting and/or unsecured plant components.**

Compressed air is a highly dangerous energy source.

Never work on the dryer when the system is under pressure.

Never direct the compressed-air outlet or condensate drain hoses at persons.

The user is responsible for the proper installation of the dryer. Non-observance of the instructions in the "Installation" chapter leads to the expiration of the guarantee. Improper installation may result in dangerous situations for the personnel and/or the device.



### Danger!

#### Supply voltage!

**Contact with non-insulated parts carrying supply voltage involves the risk of an electric shock resulting in injuries and death.**

Only qualified and skilled personnel are authorised to run electrically-operated devices. Prior to undertaking maintenance measures at the device, the following requirements must be met:

Make sure that the power supply is switched off and that the device is off and marked for maintenance measures. Please also ensure that the power supply cannot be re-established during the works.

### Caution!

#### Refrigerant!

**The compressed-air refrigeration dryer uses HFC-containing refrigerants as a coolant.**



Please observe the corresponding paragraph entitled "Maintenance works at the refrigeration cycle".



**Warning!**

**Refrigerant leak!**

**A refrigerant leak involves the danger of serious injury and damage to the environment.**



The DRYPOINT® RS 25-1010 HP50 high pressure compressed-air refrigeration dryer contains fluorinated greenhouse gas/refrigerant.

Installation, repair and maintenance works at the refrigeration system must only be carried out by certified skilled personnel (specialists). A certification in accordance with EC regulation 303/2008 must be available.



The requirements of the EC 842/2006 directive must be met under all circumstances.

Please refer to the indications on the name plate as regards the type and amount of refrigerant.

Comply with the following protective measures and rules of conduct:



- **Storage:** Keep the container tightly closed. Keep it in a cool and dry place. Protect it against heat and direct sunlight. Keep it away from ignition sources.

- **Handling:** Take measures against electrostatic charging. Ensure good ventilation/suction at the workplace. Check fittings, connections and ducts for tightness. Do not inhale the gas. Avoid contact with the eyes or the skin.



- Prior to carrying out works on refrigerant-carrying parts, remove the refrigerant to such an extent that safe working is possible.

- Do not eat, drink or smoke during work. Keep out of the reach of children.

- **Breathing protection:** ambient-air-independent respirator (at high concentrations).

- **Eye protection:** sealing goggles.

- **Hand protection:** protective gloves (e.g. made of leather).

- **Personal protection:** protective clothing.

- **Skin protection:** use protective cream.

In addition, the safety data sheet for the refrigerant needs to be observed!



**Caution!**

**Hot surfaces!**

**During operation, several components can reach surface temperatures of more than +60°C. There is the risk of burns.**

All components concerned are installed inside of the closed housing. The housing must only be opened by certified skilled personnel<sup>3</sup>.



**Caution!**

**Improper use!**



The device is intended for the separation of water in compressed air. The dried air cannot be used for breathing-air purposes and is not suitable for the direct contact with food.

This dryer is not suitable for the treatment of contaminated air or of air containing solids.

---

<sup>3</sup> Certified skilled personnel are persons who are authorised by the manufacturer, with experience and technical training, who are well-grounded in the respective provisions and laws and capable of carrying out the required works and of identifying and avoiding any risks during the machine transport, installation, operation and maintenance. Qualified and authorised operators are persons who are instructed by the manufacturer regarding the handling of the refrigeration system, with experience and technical training, and who are well-grounded in the respective provisions and laws.

**Note!****Contaminated intake air!**

In the event that the intake air is strongly contaminated (ISO 8573.1 class 3.-3 or poorer quality), we recommend the additional installation of a prefilter (e.g. CLEARPOINT HP50S040), to avoid clogging of the heat exchanger.

**Caution!****Heating-up through fire!**

**In the event of a heating-up through fire, the containers and pipes of the refrigerant system can burst.**



In this case, please proceed as follows:

Switch off the refrigeration plant.

Switch off the mechanical ventilation of the machinery compartment.

Use ambient-air-independent respirators.

Containers and plants which are filled with refrigerant can burst violently in the event of fire.

The refrigerants themselves are incombustible, but they are degraded to very toxic products at high temperatures.

Remove the container/plant from the fire zone, as there is the risk of bursting!

Cool down containers and bottles via a directed water jet from a safe position.

In the event of fire, please use an approved fire extinguisher. Water is not a suitable agent to extinguish an electrical fire.

This must only be carried out by persons who are trained and informed about the hazards emanating from the product.

**Caution!****Unauthorised intervention!**

**Unauthorised interventions may endanger persons and plants and lead to malfunction.**

Unauthorised interventions, modification and abuse of the pressure devices are prohibited.

The removal of sealings and leadings at safety devices is prohibited.

Operators of the devices must observe the local and national pressure equipment regulations in the country of installation.

**Note!****Ambient conditions!**

In the event that the dryer is not installed under suitable ambient conditions, the ability of the device to condense refrigerant gas is impaired. This can result in a higher load of the refrigerating compressor, and in a loss of efficiency and performance of the dryer.

This in turn leads to overheated condenser fan motors, to malfunction of electric components and to a breakdown of the dryer. Failures of this type will affect warranty considerations.

Do not install the dryer in an environment in which chemicals with a corrosive effect, explosive gases,

## Safety instructions

---

toxic gases, evaporation heat, high ambient temperatures or extreme dust and dirt can be found.

### 3 Proper use

This dryer was designed, manufactured and tested to separate the moisture which normally exists in compressed air. Any other use is considered improper.

The manufacturer shall not be liable for problems occurring as a consequence of improper use. The user alone is responsible for any damage resulting from that.

Furthermore, the correct use includes the compliance with the installation instructions, in particular in respect of:

- The voltage and frequency of the main voltage supply.
- The pressure, temperature and flow rate of the inlet air.
- The pressure, temperature and cooling-water throughput (water-cooled).
- The ambient temperature.

When delivered, the dryer is tested and fully assembled. The customer only needs to connect the device to the system in accordance with the instructions in the following chapters.

### 4 Exclusion from a field of application



**Note!**  
**Improper use!**



The device is intended for the separation of water in compressed air. The dried air cannot be used for breathing-air purposes and is not suitable for the direct contact with food.

This dryer is not suitable for the treatment of contaminated air or of air containing solids.

## 5 Operating instructions in accordance with the 2014/68/EU Pressure Equipment Directive

The DRYPOINT® RS 25-1010 HP50 high pressure compressed-air refrigeration dryer contains pressure equipment in the sense of the 2014/68/EU Pressure Equipment Directive. Therefore, the entire plant needs to be registered with the supervisory authority if required in accordance with the local regulations.

For the examination prior to the start-up and for periodic inspections, the national regulations need to be observed, such as the industrial safety regulation in the Federal Republic of Germany. In countries outside the EU, the respective regulations in force there need to be adhered to.

The proper use of pressure devices is the basic requirement for safe operation. As regards pressure devices, the following points need to be observed:

- The DRYPOINT® RS 25-1010 HP50 high pressure compressed-air refrigeration dryer must only be employed within the pressure and temperature range limits indicated by the manufacturer on the name plate.
- No welding must be carried out on the pressure parts.
- The DRYPOINT® RS 25-1010 HP50 high pressure compressed-air refrigeration dryer must neither be installed in insufficiently ventilated rooms nor near heat sources or inflammable substances.
- To avoid fractures resulting from material fatigue, the refrigeration dryer should not be exposed to vibrations during operation.
- The maximum operating pressure indicated by the manufacturer on the name plate must not be exceeded. It is the installer's responsibility to install the appropriate safety and control devices. Prior to the start-up of the DRYPOINT® RS 25-1010 HP50 high pressure compressed-air refrigeration dryer, the connected pressure generator (compressor etc.) must be set to the max. permissible operating pressure. The integrated safeguard needs to be checked by an approved inspection agency.
- The documents related to the DRYPOINT® RS 25-1010 HP50 high pressure compressed-air refrigeration dryer (manual, operating instructions, manufacturer's declaration etc.) must be kept safe for future reference.
- No objects whatsoever must be installed at or placed on the DRYPOINT® RS 25-1010 HP50 high pressure compressed-air refrigeration dryer and the connecting lines.
- Installation of the plant in frost-free places only.
- Operation of the plant is only permissible with fully closed and intact housing and cover panels. Operation of the plant with damaged housing/cover panels is prohibited.

## 6 Transport

Check the packaging for visible loss or damage. If no visible damage can be ascertained, place the unit in close proximity to the place of installation and unpack the device.

During this procedure, the dryer must always remain in an upright position. The components may be damaged when the unit is tilted or turned upside down.

Store the device in a dry environment and do not expose it to extreme weather conditions.

Handle with care. Strong shocks can cause irreparable damage.

## 7 Storage

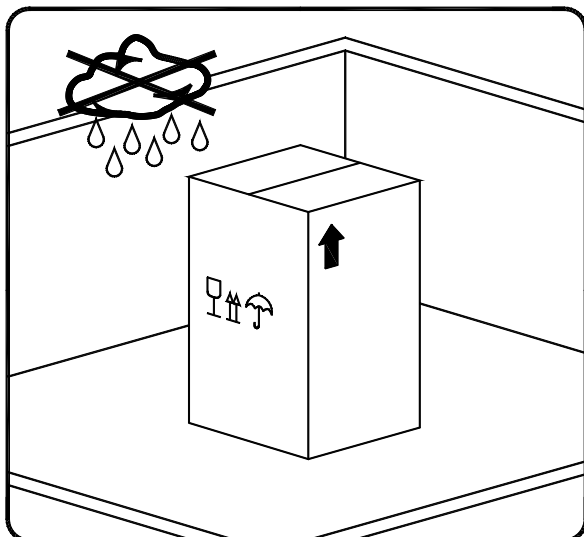

Keep the device away from extreme weather conditions even when packaged.

Keep the dryer in an upright position, also while it is stored. Tilting the device or turning it upside down can cause irreparable damage to some components.

When the dryer is not in use, it can be stored in its packaging in a dust-free and protected place at a temperature of +1°C ... +50°C and at a specific humidity of max. 90%. If the storage period exceeds 12 months, you should contact the manufacturer.



The packaging material is recyclable. Dispose of the material in accordance with the directives and provisions in force in the country of destination

## 8 Installation

### 8.1 Place of installation



**Note!**

**Ambient conditions!**

In the event that the dryer is not installed under suitable ambient conditions, the ability of the device to condense refrigerant gas is impaired. This can result in a higher load of the refrigerating compressor, and in a loss of efficiency and performance of the dryer.

This in turn leads to overheated condenser fan motors, to malfunction of electric components and to a breakdown of the dryer. Failures of this type will affect warranty considerations.

Do not install the dryer in an environment in which chemicals with a corrosive effect, explosive gases, toxic gases, evaporation heat, high ambient temperatures or extreme dust and dirt can be found.

**Minimum installation requirements:**

- Choose an area which is clean and dry, free from dust and protected against atmospheric disturbances.
- The load-bearing zone must be even, horizontal and able to bear the weight of the dryer.
- Minimum ambient temperature +1°C.
- Maximum ambient temperature +50°C.
- Ensure a proper cooling air replacement.
- Allow a sufficient clearance on each side of the dryer for proper ventilation and to facilitate maintenance operations. The dryer does not require attachment to the floor surface.



**Do not obstruct the ventilation grille (not even partially).**

Prevent any recirculation of the outgoing cooling air.

Protect the dryer against draughts.



**Note!**

Dryers models RS 25 – 135 can be wall-mounted. See fixing dimensions on dimensional drawings in the appendices section.

The hanging mounting inevitably causes the obstruction of the ventilation grid positioned on the panel facing the wall fixing. This obstruction, in any case, does not prejudice the efficiency of the ventilation inside the dryer which is guaranteed by other grids on the other panels.

## 8.2 Installation plan

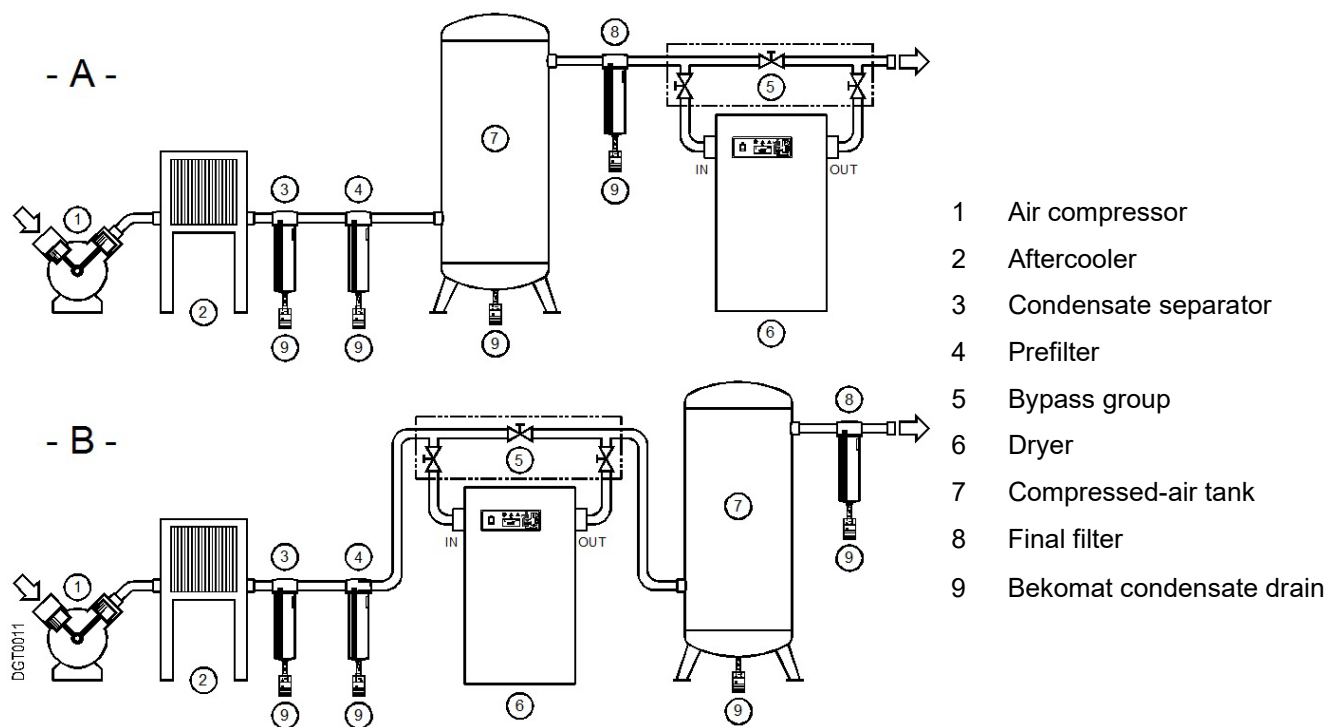

Installation **type A** is recommended when the total consumption corresponds to the throughput rate of the compressor.

Installation **type B** is recommended when the air consumption constantly varies, with peak values which considerably exceed the throughput rate of the compressor. The storage capacity of the tank must be dimensioned in such a way that a possible short-term high air demand (peak air consumption) can be compensated.



**Do not obstruct the ventilation grille (not even partially).**

Prevent any recirculation of the outgoing cooling air.

Protect the dryer against draughts.



**Note!**

**Contaminated intake air!**

In the event that the intake air is strongly contaminated (ISO 8573.1 class 3.-3 or poorer quality), we recommend the additional installation of a prefilter (e.g. CLEARPOINT HP50S040), to avoid clogging of the heat exchanger.



$$\text{Air throughput acc. to planning} = \frac{200}{0.94 \times 0.90 \times 0.69 \times 1.37} = 250 \text{ m}^3/\text{h}$$

The suitable model for these requirements is **DRYPOINT RS 320 HP50** (with a spec. nominal capacity of 315 m<sup>3</sup>/h).

#### 8.4 Connection to the compressed-air system



##### **Danger!**

##### **Compressed air!**

All works must only be carried out by qualified skilled personnel.  
Never work on compressed-air systems which are under pressure.

The operator or the user must ensure that the dryer is never operated with a pressure exceeding the maximum pressure value indicated on the name plate.

Exceeding the maximum operating pressure can be dangerous for the operator but also for the device.



The air temperature and the air flow at the inlet of the dryer must lie within the limit values indicated on the name plate. The connecting lines must be free from dust, iron rust, shards and other contaminations and correspond to the flow rate of the dryer. Should air with a very high temperature be treated, the installation of an aftercooler may be necessary. For the implementation of maintenance works, the installation of a bypass system is recommended.



##### **Note!**

##### **Pulsation and vibrations!**

Pulsations and vibrations must be eliminated from the compressed air and IN/OUT piping to avoid possible fatigue failure.

Do not use the dryer to treat air containing corrosive substances for copper and its alloys..



##### **Note!**

##### **Contaminated intake air!**

In the event that the intake air is strongly contaminated (ISO 8573.1 class 3.-3) or poorer quality, we recommend the additional installation of a prefilter (e.g. CLEARPOINT HP50S040), to avoid clogging of the heat exchanger.

#### 8.5 Connection to the cooling-water network



##### **Danger!**

##### **Compressed air and unqualified personnel!**

All works must only be carried out by qualified skilled personnel.  
Never work on compressed-air systems which are under pressure.

The user must ensure that the dryer is never operated with a pressure exceeding the nominal values.  
Possible overpressure can be dangerous for the operator but also for the device.



The temperature and the amount of cooling water need to correspond to the limit values indicated on the name plate. The cross-section of the connecting lines, which should preferably be flexible, must be free from dust, iron rust, shards and other contaminations. We recommend employing connecting lines (flexible hoses, vibration-inhibiting fittings etc.) which protect the dryer against possible vibrations in the pipework.



##### **Note!**

##### **Contaminated intake water!**

In the event that the intake water is strongly contaminated we recommend the additional installation of a prefilter (500 micron), to avoid clogging of the heat exchanger.

**8.6 Minimum cooling water requirements:**

Temperature	15 ... 30°C (1)	HCO <sub>3</sub> / SO <sub>4</sub>	>1.0 mg/l or ppm
Pressure	3...10 bar(g) (2)	NH <sub>3</sub>	<2 mg/l or ppm
Delivery pressure	> 3 bar (2) (3)	Cl <sup>-</sup>	<50 mg/l or ppm
Total hardness	6.0...15 dH°	Cl <sub>2</sub>	<0.5 mg/l or ppm
PH	7.5...9.0	H <sub>2</sub> S	<0.05 mg/l or ppm
Conductivity	10...500 µS/cm	CO <sub>2</sub>	<5 mg/l or ppm
Residual solids	<30 mg/l or ppm	NO <sub>3</sub>	<100 mg/l or ppm
Saturation mark SI	-0.2 < 0 < 0.2	Fe	<0.2 mg/l or ppm
HCO <sub>3</sub>	70...300 mg/l or ppm	Al	<0.2 mg/l or ppm
SO <sub>4</sub> <sup>2-</sup>	<70 mg/l or ppm	Mn	<0.1 mg/l or ppm

- Note:
- (1) – Other temperatures upon request – check the data on the name plate.
  - (2) – Other pressures upon request – check the data on the name plate.
  - (3) – Pressure difference at the water connection of the dryer at maximum water flow. Other delivery pressures upon request.



**CAUTION!**

During the piping of the dryer, the inlet and outlet connections need to be supported as is shown in the illustration. Non-observance will cause damage.

## 8.7 Electrical connections



### **Danger!** **Supply voltage!**

The connection to the electric mains should only be carried out by qualified skilled personnel and must correspond to the legal provisions in force in your region.

Prior to connecting the device, please check the name plate to avoid exceeding the indicated values. The voltage tolerance is +/- 10%.

Dryers are supplied with a VDE 16A standard power cord and safety plug (two-pole and earth connection) or with a junction box on the back plate.

Make sure that suitable fuses or circuit breakers in accordance with the indications on the name plate are available.

A residual-current device (RCD) with  $I_{\Delta n} = 0.03A$  is suggested. The cross-section of the power supply cable must correspond to the power consumption of the dryer. In this respect, the ambient temperature, the cable laying conditions, the length of the cables and the requirements of the local electricity supplier need to be considered.



### **Danger!** **Supply voltage and missing earth connection!**

Important: ensure that the plant is connected to earth.

Do not use plug adapters at the power plug.

Possible replacement of the power plug must only be carried out by a qualified electrician.

## 8.8 Condensate drain



### **Danger!** **Compressed air and condensate under pressure!**

The condensate is discharged at system pressure.

The drain pipe needs to be secured.

Never direct the condensate drain pipe at persons.



The dryer is delivered with an already integrated electronically level-controlled BEKOMAT condensate drain. Connect the condensate drain with a collection system or container by properly screwing it on.

Do not connect the drain with pressurised plants.



Do not discharge the condensate into the environment.

The condensate accumulating in the dryer contains oil particles which were released into the air by the compressor.

Dispose of the condensate in accordance with the local provisions.

It is advisable to install a water-oil separator, to which the total amount of condensate from the compressors, dryers, tanks, filters etc. is supplied.

We recommend ÖWAMAT oil-water separators for dispersed compressor condensate and BEKOSPLIT emulsion-splitting plants for emulsified condensate.

## 9 Start-up

### 9.1 Preliminary stages



**Note!**

**Exceeding of the operating parameters!**

Ensure that the operating parameters comply with the nominal values indicated on the name plate of the dryer (voltage, frequency, air pressure, air temperature, ambient temperature etc.).

Prior to delivery, this dryer was thoroughly tested, packed and checked. Please verify the soundness of the dryer during the initial start-up and check the perfect functioning during the first operating hours.



The initial start-up must be carried out by qualified personnel.

During the installation and operation of this device, all national regulations regarding electronics and any other federal and state ordinances, as well as local provisions, need to be adhered to.

The operator and the user must ensure that the dryer is not operated without panels.



### 9.2 Initial start-up



**Note!**

The dryer **must not be started up more than six times an hour**. Wait at least five minutes prior to every restart.

The user is responsible for the compliance with these provisions. Irreparable damage can be caused by starting up the device too often.



The method below should be applied during the first start-up, after longer downtimes or subsequent to maintenance works.

The start-up must be carried out by certified skilled personnel.

#### Processing sequence (see Section 11.1 "Control panel")

- Ensure that all steps of the "Installation" chapter have been carried out.
- Ensure that the connection to the compressed-air system is in accordance with the provisions and that the lines are fixed and supported properly.
- Ensure that the condensate drain pipe is fixed in accordance with the provisions and that it is connected with a collection system or a container.
- Ensure that the bypass system (if installed) is open and that the dryer is disconnected from the compressed-air system.
- Ensure that the manual valve of the condensate drainage cycle is open.
- Ensure that the cooling-water flow and the cooling-water temperature are in accordance with the provisions (water-cooled).
- Remove any packaging material and other items which may block the space around the dryer.
- Establish the mains connection (plug into socket).
- RS 320-1010 3phase - switch on the main switch - pos. A control panel.
- RS 320-1010 3phase - wait at least two hours before starting the dryer (the crankcase heater of the compressor needs to heat up the compressor oil).
- Start the dryer by switching on the main switch on the control panel (pos. 1).
- Make sure that the electronic control unit is switched on.
- Ensure that the power consumption complies with the values on the name plate.
- **Ensure that the fan runs properly – wait for the first interventions (air-cooled).**
- Wait until the dew point remains stable.
- Slowly open the air inlet valve.
- Slowly open the air outlet valve.
- Slowly close the central bypass valve of the system (if installed).
- Check the pipes for air leakage.
- Ensure the proper functioning of the condensate drain cycle (wait for the first condensate discharges).

**Note!**

RS 25-70 - A dew point included in the green operating area of the electronic control unit is considered to be correct according to the possible operating conditions (flow rate, air inlet temperature, ambient temperature etc.).

RS 90-1010 - A dew point between 0°C and +10°C displayed on the electronic control unit is considered to be correct according to the possible operating conditions (flow rate, air inlet temperature, ambient temperature etc.).

During the operation, the refrigerating compressor runs continuously. The dryer needs to be switched on during the entire compressed-air usage time, even if the compressed-air compressor works periodically.

**9.3 Shut down and restart**

RS 320-1010 3phase - during short-term inactivity (max. two to three days), it is advisable to leave the dryer and the control panel connected to the supply current circuit. Otherwise, it would be necessary at a restart of the dryer to wait two hours, until the crankcase heater of the compressor has heated up the oil in the compressor.

**Shut down (see Section 11.1 "Control panel")**

- Ensure that the dew point temperature indicated on the electronic control unit is stable.
- Interrupt the compressed-air supply.
- After a few minutes, stop the dryer by switching off the main switch on the control panel (pos. 1).

**Restart (see Section 11.1 "Control panel")**

- Make sure that the condenser is clean (air-cooled).
- Ensure that the cooling-water flow and the temperature are in accordance with the provisions (water-cooled).
- Check whether or not voltage is applied at the dryer.
- Start the dryer by switching on the main switch on the control panel (pos. 1).
- Ensure that the electronic control unit is switched on.
- Wait a few minutes and then check, whether or not the dew point temperature indicated on the electronic control unit is stable and whether or not the condensate is drained off at regular intervals.
- Establish the compressed-air supply.

**RS 320-1010 3phase - dryer remote control ON/OFF**

- Remove the jumper between terminals 1 and 2 of the terminal strip and wire a potential-free contact (see electric diagram).
- Switch ON the main switch - pos. 1 on the control panel.
- Close the contact at terminals 1 and 2 to switch on the dryer.
- Open the contact at terminals 1 and 2 to switch off the dryer.



Only use potential-free contacts that are suitable for 230 Vac. Ensure the sufficient insulation of potentially dangerous voltage-carrying components.

**Caution!**

**Automatic restart / remote control ON/OFF. The unit may start up without any active influence!  
The user will be responsible for the installation of proper protections for possible sudden power restoration to the dryer.**

During the operation, the refrigerating compressor runs continuously. The dryer needs to be switched on during the entire compressed-air usage time, even if the compressed-air compressor works periodically.

**Note!**

RS 25-70 - A dew point included in the green operating area of the electronic control unit is considered to be correct according to the possible operating conditions (flow rate, air inlet temperature, ambient temperature etc.).

RS 90-1010 - A dew point between 0°C and +10°C displayed on the electronic control unit is considered to be correct according to the possible operating conditions (flow rate, air inlet temperature, ambient temperature etc.).



### Note!

The dryer **must not be started up more than six times an hour**. Wait at least five minutes prior to every restart. The user is responsible for the compliance with these provisions. Irreparable damage can be caused when starting up the device too often.

## 10 Technical data

### 10.1 Technical data DRYPOINT RS 25-90 HP50 1/230/50-60

MODEL	DRYPOINT RS HP50	25	45	70	90
Air flow rate at nominal condition (1)	[m <sup>3</sup> /h]	25	45	72	90
	[l/min]	417	800	1200	1500
	[scfm]	15	28	42	53
Pressure DewPoint at nominal condition (1)	[°C]	3			
Nominal ambient temperature	[°C]	25			
Min...Max ambient temperature	[°C]	1...50			
Nominal inlet air temperature (max.)	[°C]	35 (65)			
Nominal inlet air pressure	[barg]	40			
Max. inlet air pressure	[barg]	50			
Air pressure drop - $\Delta p$	[bar]	0.25	0.24	0.25	0.23
Inlet - Outlet connections	[BSP-F]	G 3/8"			G 3/4"
Refrigerant type		R134.a			
Refrigerant quantity (2)	[kg]	0.17	0.20	0.28	0.37
Cooling air fan flow	[m <sup>3</sup> /h]	200	200	300	300
Heat Rejection	[kW]	0.45	0.57	0.68	0.87
Standard Power Supply (2)	[Ph/V/Hz]	1/230/50-60			
Nominal electric consumption @50Hz	[kW]	0.16	0.18	0.22	0.23
	[A]	1.1	1.2	1.3	1.4
Nominal electric consumption @60Hz	[kW]	0.21	0.22	0.27	0.28
	[A]	1.2	1.3	1.5	1.5
Full Load Amperage FLA	[A]	1.4	1.5	1.6	2.3
Max. noise level at 1 m	[dbA]	< 70			
Weight	[kg]	28	29	32	38

(1) The nominal condition refers to an ambient temperature of +25°C with inlet air at 40 barg and +35 °C.

(2) Check the data shown on the identification plate.

10.2 Technical data DRYPOINT RS 135-1010 HP50 1/230/50

MODEL	DRYPOINT RS HP50	135	180	240	320	450	620	810	1010
Air flow rate at nominal condition (1)	[m <sup>3</sup> /h]	135	180	240	315	450	615	810	1008
	[l/min]	2250	3000	4000	5250	7500	10250	13500	16800
	[scfm]	80	106	141	186	265	362	477	594
Pressure DewPoint at nominal condition (1)	[°C]	3							
Nominal ambient temperature	[°C]	25							
Min...Max ambient temperature	[°C]	1 ... 50							
Nominal inlet air temperature (max.)	[°C]	35 (65)							
Nominal inlet air pressure	[barg]	40							
Max. inlet air pressure	[barg]	50							
Air pressure drop - Δp	[bar]	0.23	0.24	0.24	0.20	0.22	0.22	0.23	0.22
Inlet - Outlet connections	[BSP-F]	G 3/4"			G 1"			G 1.1/2"	

Air-Cooled	Refrigerant type	R134.a	R407C							
	Refrigerant quantity (2)	[kg]	0.38	0.44	0.47	0.61	0.70	1.18	1.90	2.40
	Cooling air fan flow	[m <sup>3</sup> /h]	300	380	380	450	450	1900	2500	3300
	Heat Rejection	[kW]	1.70	2.36	2.64	3.43	4.11	4.93	6.50	7.93
	Standard Power Supply (2)	[Ph/V/Hz]	1/230/50							
	Nominal electric consumption	[kW]	0.46	0.69	0.75	0.70	0.84	1.10	1.45	1.73
		[A]	2.8	3.5	3.8	3.4	3.9	4.8	6.7	8.3
	Full Load Amperage FLA	[A]	3.5	5.3	5.9	8.8	8.9	9.0	11.2	14.3
	Max. noise level at 1 m	[dB(A)]	< 70							
	Weight	[kg]	39	50	53	89	101	115	156	190

Water-Cooled	Refrigerant type	[-]	R407C					
	Refrigerant quantity (2)	[kg]	[-]	0.55	0.63	1.10	1.70	2.20
	Max. cooling water inlet temp (3)	[°C]	[-]	30				
	Min...Max. cooling water inlet pressure	[barg]	[-]	3...10				
	Cooling water flow at 15°C	[m <sup>3</sup> /h]	[-]	0.07	0.09	0.14	0.15	0.17
	Cooling water flow at 30°C	[m <sup>3</sup> /h]	[-]	0.22	0.30	0.45	0.46	0.59
	Heat Rejection	[kW]	[-]	3.43	4.11	4.93	6.50	7.93
	Control of cooling water flow	[-]	[-]	Automatic by valve				
	Cooling water connection	[BSP-F]	[-]	G 1/2"			G 3/4"	
	Standard Power Supply (2)	[Ph/V/Hz]	[-]	1/230/50				
	Nominal electric consumption	[kW]	[-]	0.62	0.76	0.95	1.15	1.32
		[A]	[-]	3.1	3.6	4.2	5.5	6.5
	Full Load Amperage FLA	[A]	[-]	8.5	8.6	8.7	10.5	12.5
Max. noise level at 1 m	[dB(A)]	[-]	< 70					
Weight	[kg]	[-]	85	100	114	152	188	

(1) The nominal condition refers to an ambient temperature of +25°C with inlet air at 40 barg and +35 °C.

(2) Check the data shown on the identification plate.

(3) Other temperature on request.

10.3 Technical data DRYPOINT RS 320-1010 HP50 3/400/50

MODEL	DRYPOINT RS HP50	320-C	450-C	620-C	810-C	1010-C
Air flow rate at nominal condition (1)	[m <sup>3</sup> /h]	315	450	615	810	1008
	[l/min]	5250	7500	10250	13500	16800
	[scfm]	186	265	362	477	594
Pressure DewPoint at nominal condition (1)	[°C]	3				
Nominal ambient temperature	[°C]	25				
Min...Max ambient temperature	[°C]	1 ... 50				
Nominal inlet air temperature (max.)	[°C]	35 (65)				
Nominal inlet air pressure	[barg]	40				
Max. inlet air pressure	[barg]	50				
Air pressure drop - Δp	[bar]	0.20	0.22	0.22	0.23	0.22
Inlet - Outlet connections	[BSP-F]	G 1"			G 1.1/2"	

Air-Cooled	Refrigerant type	R134.a			R407C		
	Refrigerant quantity (2)	[kg]	0.93	1.00	1.50	1.67	1.76
	Cooling air fan flow	[m <sup>3</sup> /h]	2300	2500	2500	3300	3400
	Heat Rejection	[kW]	3.19	3.26	3.31	6.12	7.80
	Standard Power Supply (2)	[Ph/V/Hz]	3/400/50				
	Nominal electric consumption	[kW]	1.10	1.15	1.28	1.78	2.17
		[A]	1.7	1.8	2.3	2.6	3.9
	Full Load Amperage FLA	[A]	2.7	2.7	3.0	5.7	6.7
	Max. noise level at 1 m	[dbA]	< 70				
	Weight	[kg]	95	107	120	162	188

Water-Cooled	Refrigerant type	R134.a			R407C		
	Refrigerant quantity (2)	[kg]	0.85	0.90	1.35	1.50	1.60
	Max. cooling water inlet temp (3)	[°C]	30				
	Min...Max. cooling water inlet pressure	[barg]	3...10				
	Cooling water flow at 15°C	[m <sup>3</sup> /h]	0.08	0.09	0.10	0.13	0.16
	Cooling water flow at 30°C	[m <sup>3</sup> /h]	0.29	0.30	0.32	0.39	0.54
	Heat Rejection	[kW]	3.19	3.26	3.31	6.12	7.80
	Control of cooling water flow		Automatic by valve				
	Cooling water connection	[BSP-F]	G 1/2"			G 3/4"	
	Standard Power Supply (2)	[Ph/V/Hz]	3/400/50				
	Nominal electric consumption	[kW]	0.94	0.99	1.12	1.57	1.96
		[A]	1.6	1.7	1.8	2.3	3.2
	Full Load Amperage FLA	[A]	2.2	2.2	2.5	5.1	6.1
Max. noise level at 1 m	[dbA]	< 70					
Weight	[kg]	91	105	118	160	180	

(1) The nominal condition refers to an ambient temperature of +25°C with inlet air at 40 barg and +35 °C.

(2) Check the data shown on the identification plate.

(3) Other temperature on request.

10.4 Technical data DRYPOINT RS 25-320 HP50 1/115/60

MODEL	DRYPOINT RS HP50	25-P	45-P	70-P	90-P	135-P	180-P	240-P	320-P
Air flow rate at nominal condition (1)	[m3/h]	25	45	72	90	135	180	240	315
	[l/min]	417	800	1200	1500	2250	3000	4000	5250
	[scfm]	15	28	42	53	80	106	141	186
Pressure DewPoint at nominal condition (1)	[°C]	3							
Nominal ambient temperature	[°C]	25							
Min...Max ambient temperature	[°C]	1...50							
Nominal inlet air temperature (max.)	[°C]	35 (65)							
Nominal inlet air pressure	[barg]	40							
Max. inlet air pressure	[barg]	50							
Air pressure drop - Δp	[bar]	0.25	0.24	0.25	0.23	0.23	0.24	0.24	0.20
Inlet - Outlet connections	[BSP-F]	G 3/8"			G 3/4"				G 1"

Air-Cooled	Refrigerant type	R134.a					R407C			
	Refrigerant quantity (2)	[kg]	0.15	0.15	0.24	0.30	0.38	0.49	0.51	0.75
	Cooling air fan flow	[m3/h]	300	300	300	300	300	600	600	900
	Heat Rejection	[kW]	0.53	0.67	1.20	1.44	1.99	3.78	3.84	3.96
	Standard Power Supply (2)	[Ph/V/Hz]	1/115/60							
	Nominal electric consumption	[kW]	0.16	0.22	0.33	0.41	0.49	0.86	0.89	0.94
		[A]	1.5	2.0	3.0	3.7	4.4	7.6	8.2	8.6
	Full Load Amperage FLA	[A]	3.1	4.5	5.3	7.1	8.7	12.5	12.5	12.6
	Max. noise level at 1 m	[dbA]	< 70							
	Weight	[kg]	28	29	32	38	39	50	53	89

Water-Cooled	Refrigerant type	[-]		R407C	
	Refrigerant quantity (2)	[kg]	[-]		0.68
	Max. cooling water inlet temp (3)	[°C]	[-]		30
	Min...Max. cooling water inlet pressure	[barg]	[-]		3...10
	Cooling water flow at 15°C	[m3/h]	[-]		0.12
	Cooling water flow at 30°C	[m3/h]	[-]		0.44
	Heat Rejection	[kW]	[-]		3.96
	Control of cooling water flow		[-]		Automatic by valve
	Cooling water connection	[BSP-F]	[-]		G 1/2"
	Standard Power Supply (2)	[Ph/V/Hz]	[-]		1/115/60
	Nominal electric consumption	[kW]	[-]		0.85
		[A]	[-]		7.8
	Full Load Amperage FLA	[A]	[-]		11.8
Max. noise level at 1 m	[dbA]	[-]		< 70	
Weight	[kg]	[-]		85	

(1) The nominal condition refers to an ambient temperature of +25°C with inlet air at 40 barg and +35 °C.

(2) Check the data shown on the identification plate.

(3) Other temperature on request.

10.5 Technical data DRYPOINT RS 90-1010 HP50 1/230/60

MODEL	DRYPOINT RS HP50	90-E	135-E	180-E	240-E	320-E	450-E	620-E	810-E	1010-E	
Air flow rate at nominal condition (1)	[m <sup>3</sup> /h]	90	135	180	240	315	450	615	810	1008	
	[l/min]	1500	2250	3000	4000	5250	7500	10250	13500	16800	
	[scfm]	53	80	106	141	186	265	362	477	594	
Pressure DewPoint at nominal condition (1)	[°C]	3									
Nominal ambient temperature	[°C]	25									
Min...Max ambient temperature	[°C]	1...50									
Nominal inlet air temperature (max.)	[°C]	35 (65)									
Nominal inlet air pressure	[barg]	40									
Max. inlet air pressure	[barg]	50									
Air pressure drop - Δp	[bar]	0.23	0.23	0.24	0.24	0.20	0.22	0.22	0.23	0.22	
Inlet - Outlet connections	[BSP-F]	G 3/4"				G 1"			G 1.1/2"		

Air-Cooled	Refrigerant type	R134.a				R407C					
	Refrigerant quantity (2)	[kg]	0.25	0.30	0.49	0.51	0.78	0.88	1.30	2.10	2.20
	Cooling air fan flow	[m <sup>3</sup> /h]	300	300	600	600	900	900	2500	2800	3500
	Heat Rejection	[kW]	0.94	1.96	3.75	3.81	3.87	5.04	5.95	7.83	8.06
	Standard Power Supply (2)	[Ph/V/Hz]	1/230/60								
	Nominal electric consumption	[kW]	0.33	0.49	0.86	0.89	0.95	1.18	1.39	1.93	2.12
		[A]	1.6	2.9	3.8	4.1	4.3	5.4	6.4	8.8	9.7
	Full Load Amperage FLA	[A]	2.5	4.9	7.3	7.3	7.4	8.3	10.3	14.0	15.0
	Max. noise level at 1 m	[dbA]									
	Weight	[kg]	38	39	50	53	89	101	115	156	190

Water-Cooled	Refrigerant type		R407C							
	Refrigerant quantity (2)	[kg]				0.68	0.70	0.80	1.15	1.90
	Max. cooling water inlet temp (3)	[°C]				30				
	Min...Max. cooling water inlet pressure	[barg]				3...10				
	Cooling water flow at 15°C	[m <sup>3</sup> /h]				0.12	0.15	0.16	0.20	0.23
	Cooling water flow at 30°C	[m <sup>3</sup> /h]				0.44	0.58	0.61	0.69	0.76
	Heat Rejection	[kW]				3.87	5.04	5.95	7.83	8.06
	Control of cooling water flow					Automatic by valve				
	Cooling water connection	[BSP-F]				G 1/2"			G 3/4"	
	Standard Power Supply (2)	[Ph/V/Hz]				1/230/60				
	Nominal electric consumption	[kW]				0.86	1.10	1.20	1.65	1.75
		[A]				4.0	5.1	5.7	7.6	8.1
	Full Load Amperage FLA	[A]				7.1	8.0	9.6	13.3	14.3
Max. noise level at 1 m	[dbA]				< 70					
Weight	[kg]				85	100	114	152	188	

- (1) The nominal condition refers to an ambient temperature of +25°C with inlet air at 40 barg and +35 °C.
- (2) Check the data shown on the identification plate.
- (3) Other temperature on request.

10.6 Technical data DRYPOINT RS 320-1010 HP50 3/460/60

MODEL	DRYPOINT RS HP50	320-R	450-R	620-R	810-R	1010-R
Air flow rate at nominal condition (1)	[m <sup>3</sup> /h]	315	450	615	810	1008
	[l/min]	5250	7500	10250	13500	16800
	[scfm]	186	265	362	477	594
Pressure DewPoint at nominal condition (1)	[°C]	3				
Nominal ambient temperature	[°C]	25				
Min...Max ambient temperature	[°C]	1...50				
Nominal inlet air temperature (max.)	[°C]	35 (65)				
Nominal inlet air pressure	[barg]	40				
Max. inlet air pressure	[barg]	50				
Air pressure drop - Δp	[bar]	0.20	0.22	0.22	0.23	0.22
Inlet - Outlet connections	[BSP-F]	G 1"			G 1.1/2"	

Air-Cooled	Refrigerant type	R134.a			R407C		
	Refrigerant quantity (2)	[kg]	0.90	0.98	1.45	1.80	1.95
	Cooling air fan flow	[m <sup>3</sup> /h]	2500	2800	2800	3600	3700
	Heat Rejection	[kW]	4.02	4.16	4.37	7.30	9.47
	Standard Power Supply (2)	[Ph/V/Hz]	3/460/60				
	Nominal electric consumption	[kW]	1.13	1.28	1.67	2.50	2.75
		[A]	1.8	1.9	2.6	3.9	4.2
	Full Load Amperage FLA	[A]	2.8	2.8	4.5	6.4	7.4
	Max. noise level at 1 m	[dbA]	< 70				
	Weight	[kg]	95	107	120	162	188

Water-Cooled	Refrigerant type	R134.a			R407C		
	Refrigerant quantity (2)	[kg]	0.80	0.90	1.30	1.60	1.80
	Max. cooling water inlet temp (3)	[°C]	30				
	Min...Max. cooling water inlet pressure	[barg]	3...10				
	Cooling water flow at 15°C	[m <sup>3</sup> /h]	0.11	0.13	0.14	0.19	0.22
	Cooling water flow at 30°C	[m <sup>3</sup> /h]	0.43	0.46	0.53	0.72	0.79
	Heat Rejection	[kW]	4.02	4.16	4.37	7.30	9.47
	Control of cooling water flow		Automatic by valve				
	Cooling water connection	[BSP-F]	G 1/2"			G 3/4"	
	Standard Power Supply (2)	[Ph/V/Hz]	3/460/60				
	Nominal electric consumption	[kW]	0.95	1.10	1.50	2.00	2.20
		[A]	1.7	1.8	2.2	2.6	3.2
	Full Load Amperage FLA	[A]	2.2	2.2	3.9	5.0	6.0
Max. noise level at 1 m	[dbA]	< 70					
Weight	[kg]	91	105	118	160	180	

(1) The nominal condition refers to an ambient temperature of +25°C with inlet air at 40 barg and +35 °C.

(2) Check the data shown on the identification plate.

(3) Other temperature on request.

## 11 Technical description

### 11.1 Control panel

The control panel explained below is the only dryer user interface.

RS 25 – 70

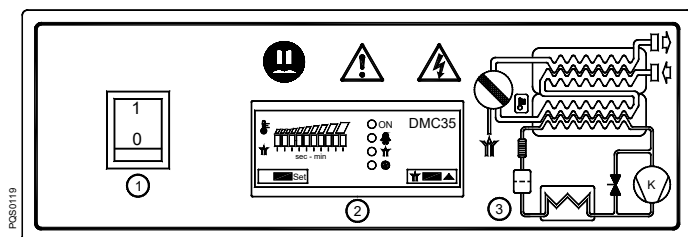

RS 90 – 240

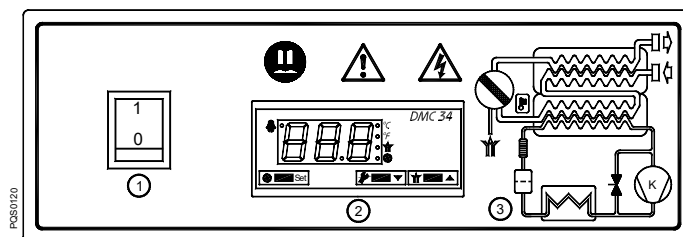

RS 320 – 1010

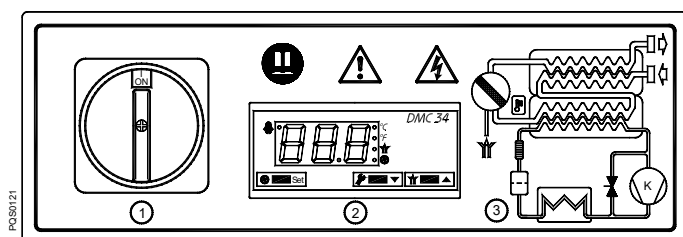

RS 320 – 1010 3phase

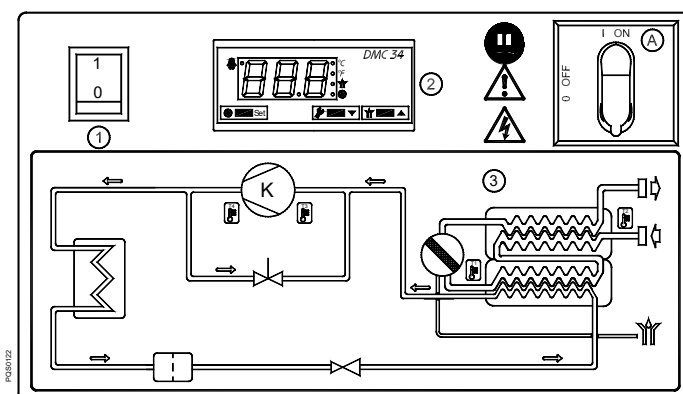

- A Main switch
- 1 ON-OFF switch
- 2 Electronic instrument
- 3 Air and refrigerant flow diagram

### 11.2 Functional description

**Operating principle** – All dryer models described in this manual function according to the same principle. The hot and moisture-loaded air is led into an air/air heat exchanger. Afterwards, the air flows through an evaporator, which is also known as an air/refrigerant heat exchanger. The air temperature is reduced to approximately 2°C, so that water vapour condenses to liquid. The continuously accumulating condensate is collected in the separator to be discharged via the condensate drain. Subsequently, the cold and dry air is led through the air/air heat exchanger, so that it is reheated to up to 8°C below the inlet temperature when leaving the dryer.

**Refrigeration cycle** – The refrigerant is conducted through the compressor and reaches a condenser under high pressure. There, cooling-down takes place, making the refrigerant condense to a liquid state which is under high pressure. The liquid is pressed through a capillary tube where the resulting pressure drop ensures that the refrigerant evaporates at a defined temperature. The liquid refrigerant which is under low pressure is led into the heat exchanger, where it expands. The cold resulting from the expansion serves to cool down the compressed air in the heat exchanger. During this process, the refrigerant evaporates. The low-pressure gas is resupplied to the compressor, where it is compressed again. It then re-enters the cycle. In phases of a reduced compressed-air load, the excess refrigerant is resupplied automatically to the compressor via the hot gas bypass valve.

11.3 Flow chart (air-cooled)

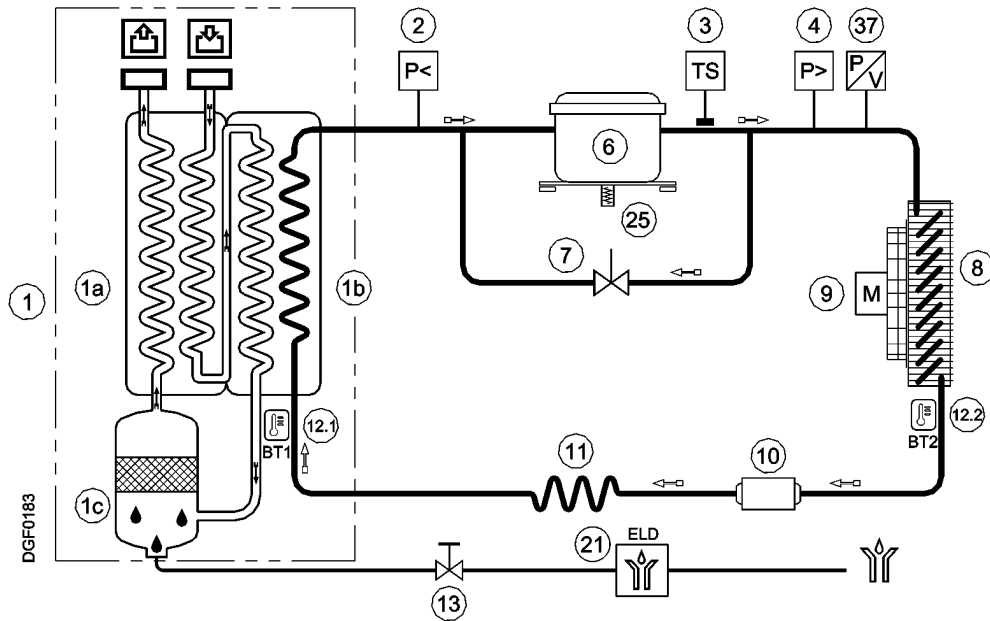

11.4 Flow chart (water-cooled)

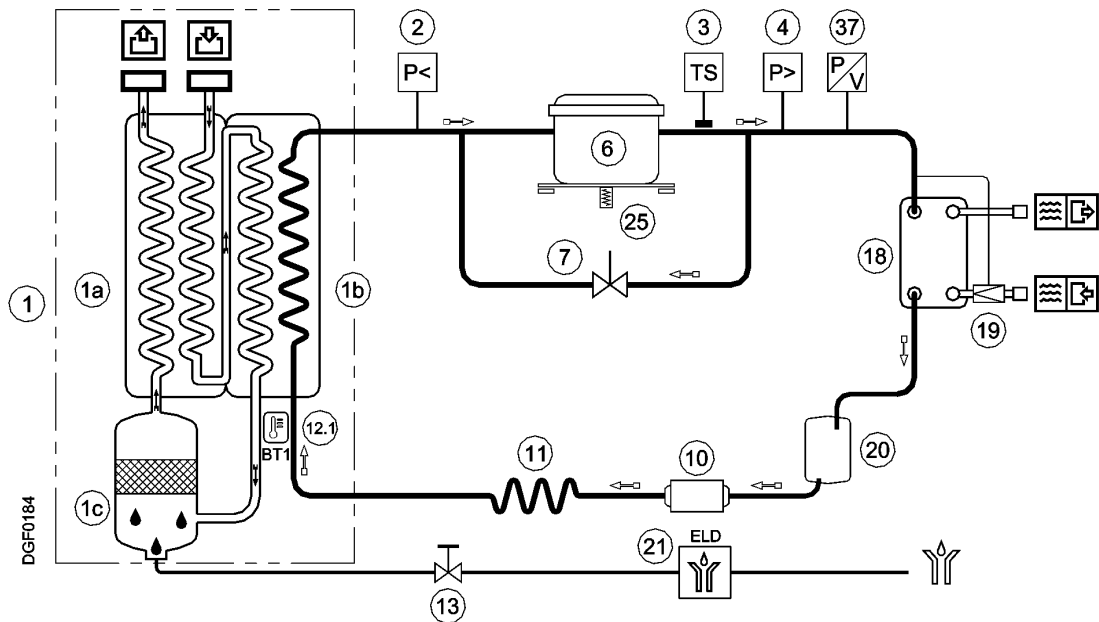

- |   |  |      |  |
|---|--|------|--|
| 1 | Heat exchanger group   | 10   | Filter dryer                                     |
| a | Air/air heat exchanger   | 11   | Capillary tube                                   |
| b | Air/refrigerant heat exchanger   | 12.1 | T1 temperature sensor (dew point)                |
| c | Condensate separator   | 12.2 | T2 Temperature sensor (fan control) (RS 25-70)   |
| 2 | Refrigerant pressure switch LPS (P<)<br>(RS 810-1010 & RS 320-1010 3phase) | 13   | Condensate drain shut-off valve                  |
| 3 | Safety temperature switch TS (RS 320-1010 & RS 320-1010 3phase)            | 18   | Condenser (water-cooled)                         |
| 4 | Refrigerant pressure switch HPS (P>)                                       | 19   | Cooling-water regulating valve (water-cooled)    |
| 6 | Refrigerating compressor   | 20   | Liquid collector (water-cooled)                  |
| 7 | Hot-gas bypass valve   | 21   | BEKOMAT condensate drain                         |
| 8 | Condenser (air-cooled)   | 25   | Compressor crankcase heater (RS 320-1010 3phase) |

9 Condenser fan (air cooled)

37 Pressure transducer  
(RS 90-1010 & RS 320-1010 3phase)

 Compressed-air flow direction

 Refrigerant gas flow direction

### 11.5 Refrigerating compressor

The employed refrigerating compressors are constructed by leading manufacturers. The hermetically sealed construction is absolutely gastight. The integrated safeguard protects the compressor against overheating and excess current. The protection is automatically reset as soon as the nominal conditions are reached again.

### 11.6 Condenser (air-cooled)

The condenser is the component in which the gas coming from the compressor is cooled down, condensed and liquefied. Under no circumstances must the temperature of the ambient air exceed the nominal values. It is also important that the condenser unit is kept free from dust and other impurities.

### 11.7 Condenser (water-cooled)

The condenser is the component in which the gas coming from the compressor is cooled-down, condensed and liquefied. The water inlet temperature must not exceed the nominal values. Likewise, a correct flow must be ensured. The water entering the condenser must be free from impurities.

### 11.8 Cooling-water regulating valve

The cooling-water regulating valve serves to keep the condensation pressure or the condensation temperature constant during water cooling. When the dryer is switched off, the valve automatically blocks the cooling-water flow.



The condenser water regulating valve is an operating control device.

The closure of the water circuit from the pressure condenser water regulating valve cannot be used as a safety closure during service operations on the system.



#### ADJUSTMENT

The condenser water regulating valve is adjusted during the testing phase to a pre-set value that covers 90% of the applications. However, sometimes the extreme operating conditions of the dryer may require a more accurate calibration.

During start-up, a qualified technician should check the condensing pressure/temperature and if necessary adjust the valve by using the screws on the valve itself.

To increase the condensing temperature, turn the adjusting screws counter-clockwise; to lower it turn the screws clock-wise.

Water valve setting : R134.a pressure 10 barg ( $\pm 0.5$  bar)  
R407C pressure 16 barg ( $\pm 0.5$  bar)

### 11.9 Filter dryer

Despite controlled vacuuming, traces of moisture can accumulate in the refrigeration cycle. The filter dryer serves to absorb this moisture and to bond it.

### 11.10 Capillary tube

The capillary tube is a copper tube with a reduced diameter which is located between the condenser and the evaporator, serving as a restrictor to reduce the pressure of the refrigerant. The pressure reduction serves to reach an optimum temperature inside of the evaporator. The lower the outlet pressure at the capillary tube, the lower the evaporation temperature.

The length and the inner diameter of the capillary tube are exactly dimensioned to ensure the performance of the dryer. Settings or maintenance works are not required.

### 11.11 Air-to-air heat exchanger

The purpose of this exchanger is to drop the heat of the incoming compressed air onto the outgoing cold air. The benefits of this solution are essentially two: the incoming air is already partially cooled so the refrigerating circuit can be sized as to assure a limited thermal heat, with a 40÷50% energy saving. Secondly no cold air is allowed into the compressed air line, thus preventing the system's pipes sweating.

### **11.12 Air-to-refrigerant heat exchanger**

Also called evaporator. The liquid formed in the condenser is evaporated in this part of the circuit. In the evaporation phase the refrigerant tends to absorb the heat from the compressed air present in the other side of the exchanger. Refrigerant and air are in counter flow, thus contributing to limit pressure drop and to provide efficient thermal exchange.



suction side of the compressor. When the system is connected with the electric mains and the compressor is idle, the heater will keep the oil at the correct temperature.

This heater is controlled via a temperature switch which prevents the overheating of the oil.

**Note:** The heater must be connected to the mains at least a few hours prior to the start-up of the refrigerating compressor.

11.18 DMC 35 electronics (control unit compressed-air dryer) – RS 25-70

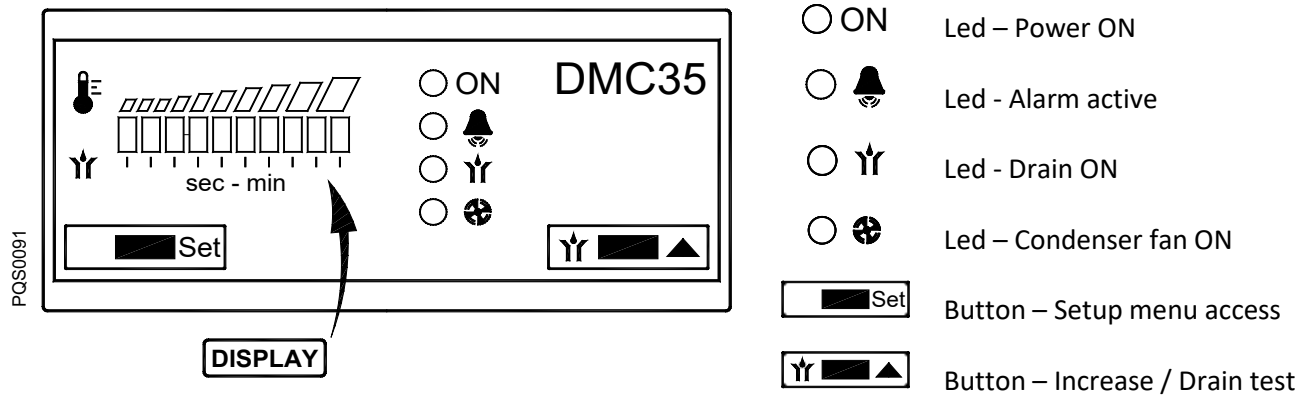

The DMC35 displays DewPoint temperature, controls the condenser fan activation, controls the timed drainer and keep record of the total hours of operation of the dryer.

11.18.1 How to switch on the dryer

Power the dryer and switch it on using the ON-OFF switch (pos.1 paragraph 7.1).

During normal operation led ○ ON is ON and the display shows the DewPoint temperature by means of two coloured areas (green and red) above a 10 Led display :

- Green area - operating conditions ensuring an optimal DewPoint;
- Red area - DewPoint too high, the dryer is operating with high thermal load (high inlet air temperature, high ambient temperature, etc.). Compressed air treatment may be improper.

Led ○ shows that one or more service warnings / alarms are active.

Led ○ shows that condensate drain solenoid valve is ON.

Led ○ shows that condenser fan is ON.

The condensate drain test is always active using the button .

11.18.2 How to switch off the dryer

Switch it off using the ON-OFF switch (pos.1 paragraph 7.1).

11.18.3 How a service warning / alarm is displayed

A service warning / alarm is an unusual event that must recall the attention of the operators/maintenance technicians. It does not stop the dryer.

Service warnings / alarms are automatically reset as soon as the problem is solved and dryer is powered again.



**NOTE: the operator/maintenance technician must inspect the dryer and verify/solve the problem that generated the service warning.**

Service Warning / Alarm	Description
Led ○  and display 1st (left) and 10th (right) led are flashing	Failure BT1 (DewPoint) temperature probe.
Led ○  and led ○  are flashing	Failure BT2 / BP2 (fan control) probe. NOTE : fan is forced always ON.
Led ○  and display 1st (left) led are flashing	DewPoint too low (lower than -1°C / 30°F).



**11.18.4 How is controlled the condenser fan**

A temperature probe BT2 is located on the discharge side of the condenser. The condenser fan is activated (ON) when the T2 temperature is higher than FANon setting (approx. 35°C / 96°F) and led  is ON. Condenser fan stops when T2 temperature is lower than FANoff setting (approx. 30°C/86°F).

### 11.18.5 How is controlled the drain solenoid valve



Drain solenoid valve is activated (ON) for  $T_{ON}$  seconds (standard 2 seconds) every  $T_{OFF}$  minutes (standard 1 minute). Led   shows that condensate drain solenoid valve is ON.

The condensate drain test is always active using the button .



**NOTE** : if an electronic drainer is installed, DMC35 is set to keep always powered the drain output, Led   is always OFF and condensate drain test does not work.



### 11.18.6 How to display the total hours of operation

Total hours of operation are recorded into DMC35 and are shown through the dew point indication bar (max value 109900 hours, cannot be reset).

With dryer ON press buttons  and  for at least 5 seconds.

Led  ON is lit and a certain numbers of leds of dew point indication bar are light up. The number of leds lit define the 1st digit of hour counter (ie : no leds lit → 1st digit =0)

Press  button, led   is lit and a certain numbers of leds of dew point indication bar are light up. The number of leds lit define the 2nd digit of hour counter (ie : n.3 leds lit → 2nd digit = 3)

Press  button, led   is lit and a certain numbers of leds of dew point indication bar are light up. The number of leds lit define the 3rd digit of hour counter (ie : n.8 leds lit → 3rd digit = 8)

Total operating hours :  $0\ 3\ 8 \times 100$  (fixed multiplying ratio) = 3800 hours

Press  button repeatedly to scroll the displaying of 3 digits again.

Press  button to exit total hours display (if no button is pressed after 30 seconds the menu is exited automatically).

### 11.18.7 How to change the operating parameters





The setup menu can be used to change the dryer's operating parameters







Only qualified personnel must be allowed to access to the setup menu. The manufacturer is not responsible for malfunctioning or failure due to modification to the operating parameters.

With dryer ON press button  for at least 2 seconds to enter the setup menu.



Access to the menu is confirmed by led  ON flashing.

Keep  pressed and use arrows  to change the value. Release the button  to confirm the value. Press shortly  to skip to following parameter.

Press  to exit setup menu (if no button is pressed after 2 minutes the menu is exited automatically).

Display	Description	Limits	Resolution	Standard setup
Synchronous flashing led  ON + led 	$T_{ON}$ – drain time ON : time ON condensate drain valve (1)	1 ... 6 sec	1 sec	2
Non-synchronous flashing led  ON + led 	$T_{OFF}$ - drain time OFF : pause time for condensate drain valve	1 ... 10 min	1 min	1

**NOTE** : parameter values are displayed on the 10 led display where 1st (left) led is the lowest limit and 10th (right) is the highest limit.

**NOTE (1)** :  $T_{ON}$  set at the 10th led (right) keep drain output always powered and led   always off (used if electronic drainer is installed)

### 11.19 DMC 34 electronics (control unit compressed-air dryer)

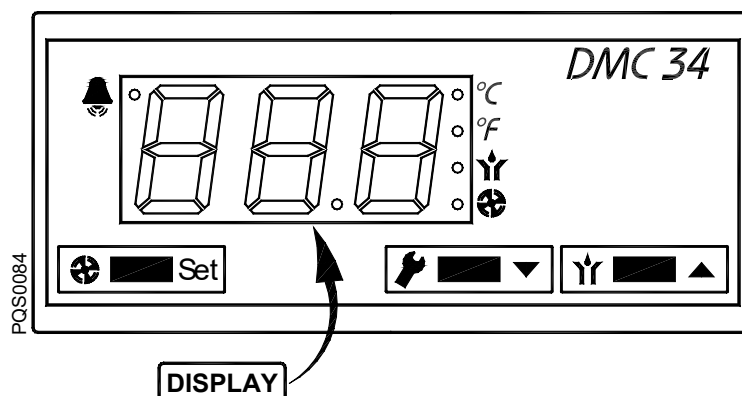

PQS0084

- °C Led - Temperature in °C
- °F Led - Temperature in °F
- Y Led – Drain ON
- ⊕ Led – Fan ON
- 🔔 Led – Alarm/Service

- Button – Setup menu access / Condensing
- Button – Decrease / Service
- Button – Increase / Drain test

The DMC34 displays DewPoint temperature, controls the condenser fan activation, handles a service reminder and keep record of the total hours of operation of the dryer.

#### 11.19.1 How to switch on the dryer

Power the dryer and switch it on using the ON-OFF switch (pos. 1 paragraph 7.1).

During normal operation the display shows the DewPoint temperature.

The condensate drain test is always active using the button .

#### 11.19.2 How to switch off the dryer

Switch it off using the ON-OFF switch (pos. 1 paragraph 7.1).

#### 11.19.3 How to display the operating parameters

During normal operation, the display shows the DewPoint temperature (in °C or °F).

Press and hold button to display condensing pressure.

Press and hold button to display hours until the next service.

Press and hold + buttons to display total hours of operation of the dryer (cannot be reset).

**NOTE :** with led ○ °C on temperatures are in °C and pressure in barg; with led ○ °F on temperatures are in °F and pressure in psig.

The total hours of operation and the hours until the next service are shown in the field 0...999 hours and in thousands of hours from 01.0 hours on (example : if the display shows number 35 it means 35 hours; if the display shows number 3.5 it means 3500 hours).





**11.19.4 How a service warning / alarm is displayed**

A service warning / alarm is an unusual event that must recall the attention of the operators/maintenance technicians. It does not stop the dryer.

When a service warning / alarm is active, the  led is lighted or flashing.

Service warnings / alarms are automatically reset as soon as the problem is solved and dryer is powered again. Scheduled Service reminder requires manual reset.

**NOTE: the operator/maintenance technician must inspect the dryer and verify/solve the problem that generated the service warning.**

Service Warning / Alarm	Description
 flashing + <b>PF 1</b> on display	PF1 - Probe 1 Failure : failure temperature probe BT1
 flashing + <b>PF 2</b> on display	PF2 - Probe 2 Failure : failure pressure probe BP2
 flashing + <b>HdP</b> on display	HdP - High DewPoint: DewPoint too high Set $BT1 > HdS$ , delay Hdd / Reset $BT1 < HdS - 1^{\circ}C$ ( $HdS - 2^{\circ}F$ )
 flashing + <b>LdP</b> on display	LdP - Low DewPoint : DewPoint too low Set $BT1 < -1^{\circ}C$ ( $30^{\circ}F$ ), delay 5 minutes / Reset $T1 > 1^{\circ}C$ ( $34^{\circ}F$ )
 flashing + <b>SrV</b> on display	SrV - Service : maintenance service time expired SrV

**11.19.5 How is controlled the condenser fan**

A pressure probe BP2 is located on the discharge side of the compressor. The condenser fan is activated (ON) when the BP2 pressure is higher than FANon setting (R134a approx. 11 barg/160 psig – R407C approx. 18 barg/260 psig) and led  is ON. Condenser fan stops when BP2 pressure is lower than FANoff setting (R134a approx. 8 barg/115 psig – R407C approx. 14 barg/203 psig).



**11.19.6 How is controlled the drain solenoid valve**

Drain solenoid valve is activated (ON) for **ton** seconds (standard 2 seconds) every **tof** minutes (standard 1 minute). Led  shows that condensate drain solenoid valve is ON.

The condensate drain test is always active using the button .

**NOTE :** if an electronic drainer is installed, DMC34 is set to keep always powered the drain output (**ton** = ON).

**11.19.7 How to reset the service reminder timer**

With dryer OFF keep pressed buttons  Set + , power the dryer and switch it on using the ON-OFF switch (pos.1 paragraph 7.1).

After 5 seconds display shows **SrV**, release buttons  Set + , keep pressed button  for 5 seconds. Timer has been reset and controller start to operate regularly.

Service reminder timing can be reset at any time, even before the timing has expired.

**11.19.8 Operation of the failure / alarm dry contact**

The DMC34 is equipped with a dry contact (potential free) to display failure and/or alarm conditions.



Dryer powered and no service warning / alarm is active.



Dryer not powered or service warning / alarm is active.

11.19.9 How to change the operating parameters

The setup menu can be used to change the dryer’s operating parameters.



Only qualified personnel must be allowed to access to the setup menu. The manufacturer is not responsible for malfunctioning or failure due to modification to the operating parameters.

With dryer ON simultaneously press buttons + for at least 5 seconds to enter the setup menu.

Access to the menu is confirmed by message **ton** on the display (first parameter of menu).

Keep pressed to display the value of the selected parameter and use arrows and to change the value. Release the button to confirm the value and skip to following parameter.

Press + to exit setup menu (if no button is pressed after 2 minutes the menu is exited automatically).

ID	Description	Limits	Resolution	Standard setup
<b>ton</b>	Ton – drain time ON : time ON condensate drain valve ON = Electronic drainer installed	ON 00 ... 20 sec	1 sec	2
<b>toF</b>	ToF - drain time OFF : pause time for condensate drain valve	1 ... 20 min	1 min	1
<b>HdS</b>	HdS – High DewPoint Setting : Alarm threshold for a high DewPoint (the alarm disappears when the temperature drop 1°C / 2°F below alarm point)	0.0...25.0 °C or 32 ... 77 °F	0.5 °C or 1 °F	20 or 68
<b>Hdd</b>	Hdd - High DewPoint Delay : high DewPoint alarm enable delay	01 ... 20 minutes	1 min	15
<b>SrL</b>	SrV - Service Setting: setting of service warning timer. 00 = service warning timer disabled.	00.0 ... 20.0 (x 1000) hours	0.5 (x1000) hours	08.0
<b>SrC</b>	SrC – Service Contact : configuration of the alarm dry contact for the service warning timer. YES = activate the contact / NO = NOT activate the contact	YES / NO	-	YES
<b>SCL</b>	SCL - Scale: display scale of temperatures and pressure (°C = temperatures in °C and pressure in barg; °F = temperatures in °F and pressure in psig)	°C ... °F	-	°C

## 11.20 Electronically level-controlled BEKOMAT condensate drain

The electronically level-controlled BEKOMAT condensate drain boasts a special condensate management which ensures that condensate is discharged safely and without an unnecessary loss of compressed air. This drain has a condensate collection container in which a capacitive sensor continuously monitors the liquid level. As soon as the switching level is reached, the capacitive sensor transmits a signal to the electronic control and a membrane solenoid valve opens to discharge the condensate. The BEKOMAT closes before compressed air emerges.



### Note!

These BEKOMAT condensate drains were designed in particular for the operation in a **DRYPOINT RS HP50** refrigeration dryer. The installation in other compressed-air processing systems or the replacement with another drain brand can lead to malfunction. The maximum operating pressure (see name plate) must not be exceeded!

**Ensure that the upstream valve is open when the dryer starts operation.**

**To obtain detailed information regarding drain functions, troubleshooting, maintenance and spare parts, please read the installation and operating instructions of the BEKOMAT condensate drain.**

## 12 Maintenance, troubleshooting, spare parts and dismantling

### 12.1 Checks and maintenance



#### Certified skilled personnel

Installation works must exclusively be carried out by authorised and qualified skilled personnel. Prior to undertaking any measures on the DRYPOINT® RS 25-1010 HP50 high pressure compressed-air refrigeration dryer, the certified skilled personnel<sup>4</sup> shall read up on the device by carefully studying the operating instructions. The operator is responsible for the adherence to these provisions. The respective directives in force apply to the qualification and expertise of the certified skilled personnel.

For safe operation, the device must only be installed and operated in accordance with the indications in the operating instructions. In addition, the national and operational statutory provisions and safety regulations, as well as the accident prevention regulations required for the respective case of application, need to be observed during employment. This applies accordingly when accessories are used.



#### Danger!

##### Compressed air!

**Risk of serious injury or death through contact with quickly or suddenly escaping compressed air or through bursting and/or unsecured plant components.**

Compressed air is a highly dangerous energy source.

Never work on the dryer when the system is under pressure.

Never direct the compressed-air outlet or condensate drain hoses at persons.

The user is responsible for the proper maintenance of the dryer. Non-observance of the instructions in the "Installation" and "Maintenance, troubleshooting, spare parts and dismantling" chapters leads to the expiration of the guarantee. Improper maintenance may result in dangerous situations for the personnel and/or the device.



#### Danger!

##### Supply voltage!

**Contact with non-insulated parts carrying supply voltage involves the risk of an electric shock resulting in injuries and death.**

Only qualified and skilled personnel are authorised to run electrically-operated devices. Prior to undertaking maintenance measures at the device, the following requirements must be met:

Make sure that the power supply is switched off and that the device is off and marked for maintenance measures. Please also ensure that the power supply cannot be re-established during the works.



Prior to carrying out maintenance works at the dryer, switch it off and wait for at least 30 minutes.



#### Caution!

##### Hot surfaces!

**During operation, several components can reach surface temperatures of more than +60°C. There is the risk of burns.**

All components concerned are installed inside of the closed housing. The housing must only be opened by certified skilled personnel.

Some components can reach high temperatures during operation. Avoid any contact until the system or the component has cooled down.

---

<sup>4</sup> Certified skilled personnel are persons who are authorised by the manufacturer, with experience and technical training, who are well-grounded in the respective provisions and laws and capable of carrying out the required works and of identifying and avoiding any risks during the machine transport, installation, operation and maintenance. Qualified and authorised operators are persons who are instructed by the manufacturer regarding the handling of the refrigeration system, with experience and technical training, and who are well-grounded in the respective provisions and laws.

**DAILY:**

- Check whether the dew point indicated on the electronics is correct.
- Ensure that the condensate drain system functions properly.
- Make sure that the condenser is clean.

**EVERY 200 HOURS OR MONTHLY**

- Clean the condenser using an air jet (max. 2 bar / 30 psig) inside out. Make sure not to damage the aluminium lamellae of the cooling package.
- Finally, verify the operation of the device.

**EVERY 1,000 HOURS OR ANNUALLY**

- Verify all screws, clamps and connections of the electric system to make sure that they are fastened securely. Check the device for broken and ruptured cables or cables without insulation.
- Check the refrigeration cycle for signs of oil and refrigerant leaks.
- Measure the current strength and note it down. Ensure that the read values are within the permissible limit values, as indicated in the specification table.
- Check the hose lines of the condensate drain and replace them, if required.
- Finally, verify the operation of the device.

**EVERY YEAR**

- Clean housing and valve of BEKOMAT
- Replace BEKOMAT wearing parts

**12.2 Troubleshooting****Certified skilled personnel**

Installation works must exclusively be carried out by authorised and qualified skilled personnel. Prior to undertaking any measures on the DRYPOINT® RS 25-1010 HP50 high pressure compressed-air refrigeration dryer, the certified skilled personnel shall read up on the device by carefully studying the operating instructions. The operator is responsible for the adherence to these provisions. The respective directives in force apply to the qualification and expertise of the certified skilled personnel. For safe operation, the device must only be installed and operated in accordance with the indications in the operating instructions. In addition, the national and operational statutory provisions and safety regulations, as well as the accident prevention regulations required for the respective case of application, need to be observed during employment. This applies accordingly when accessories are used.

**Danger!****Compressed air!**

**Risk of serious injury or death through contact with quickly or suddenly escaping compressed air or through bursting and/or unsecured plant components.**

Compressed air is a highly dangerous energy source.

Never work on the dryer when the system is under pressure.

Never direct the compressed-air outlet or condensate drain hoses at persons.

The user is responsible for the proper maintenance of the dryer. Non-observance of the instructions in the "Installation" and "Maintenance, troubleshooting, spare parts and dismantling" chapters leads to the expiration of the guarantee. Improper maintenance may result in dangerous situations for the personnel and/or the device.



**Danger!**

**Supply voltage!**

Contact with non-insulated parts carrying supply voltage involves the risk of an electric shock resulting in injuries and death.

Only qualified and skilled personnel are authorised to run electrically-operated devices. Prior to undertaking maintenance measures at the device, the following requirements must be met:

Make sure that the power supply is switched off and that the device is off and marked for maintenance measures. Please also ensure that the power supply cannot be re-established during the works.



Prior to carrying out maintenance works at the dryer, switch it off and wait for at least 30 minutes.



**Caution!**  
**Hot surfaces!**

During operation, several components can reach surface temperatures of more than +60°C. There is the risk of burns.

All components concerned are installed inside of the closed housing. The housing must only be opened by certified skilled personnel.

Some components can reach high temperatures during operation. Avoid any contact until the system or the component has cooled down.

**FAULT**

**POSSIBLE REASON – SUGGESTED MEASURE**

◆ The dryer does not start.	<ul style="list-style-type: none"> <li>⇒ Check whether or not the dryer is connected with the electric mains.</li> <li>⇒ Check the electric cabling.</li> <li>⇒ RS 320-1010 3phase- Blow of fuse (FU3 on the electric diagram) of the auxiliary circuit - replace it and check the proper operation of the dryer.</li> </ul>
◆ The refrigerating compressor does not work.	<ul style="list-style-type: none"> <li>⇒ The internal heat protection of the compressor was activated – wait 30 minutes and then retry.</li> <li>⇒ Check the electric cabling.</li> <li>⇒ If installed – replace the internal heat protection and/or the start-up relay and/or the starting capacitor and/or the operating capacitor.</li> <li>⇒ HPS pressure switch was activated – see the corresponding point.</li> <li>⇒ If installed – the LPS pressure switch was activated – see the corresponding point.</li> <li>⇒ If installed – the TS safety temperature switch was activated – see the corresponding point.</li> <li>⇒ In the event that the compressor still does not work, replace it.</li> </ul>
◆ The fan of the condenser does not work (air-cooled).	<ul style="list-style-type: none"> <li>⇒ Check the electric cabling.</li> <li>⇒ RS 25-70 - The DMC15 electronic control unit is faulty – replace it.</li> <li>⇒ RS 90-1010 - The PV pressure switch is defective. Contact a BEKO service technician.</li> <li>⇒ RS 320-1010 3phase- Blow of fuse (FU1-FU2 on the electric diagram) - replace it and check the proper operation of the dryer.</li> <li>⇒ There is a leak in the refrigeration cycle – contact a BEKO service technician.</li> <li>⇒ In the event that the fan still does not work, replace it.</li> </ul>
◆ Dew point too high.	<ul style="list-style-type: none"> <li>⇒ The dryer does not start up – see the corresponding point.</li> <li>⇒ The T1 dew point sensor does not record the temperature properly – ensure that the sensor is pushed down to the bottom of the aluminium tube immersion sleeve.</li> <li>⇒ The refrigerating compressor does not work – see the corresponding point.</li> <li>⇒ The ambient temperature is too high or the room ventilation insufficient – ensure sufficient ventilation (air-cooled).</li> <li>⇒ The inlet air is too hot – re-establish the nominal conditions.</li> <li>⇒ The inlet air pressure is too low – re-establish the nominal conditions.</li> <li>⇒ The inlet air throughput is higher than the throughput of the dryer – reduce the flow rate - re-establish the nominal conditions.</li> <li>⇒ The condenser is dirty – please clean it (air-cooled).</li> <li>⇒ The condenser fan does not work – see the corresponding point (air-cooled).</li> <li>⇒ The cooling-water flow is insufficient – re-establish the nominal conditions (water-cooled).</li> <li>⇒ The dryer does not discharge the condensate – see the corresponding point.</li> <li>⇒ The hot-gas bypass valve needs to be re-adjusted – contact a BEKO service technician to have the nominal setting re-established.</li> <li>⇒ There is a leak in the refrigeration cycle – contact a BEKO service technician.</li> </ul>
◆ Dew point too low.	<ul style="list-style-type: none"> <li>⇒ RS 25-70 - The fan is always ON - Led  and led  are flashing - see specific point.</li> <li>⇒ RS 90-1010 - The fan is always ON – Led  is flashing + display <b>PF2</b> - see specific point (Air-Cooled).</li> <li>⇒ The ambient temperature is too low –re-establish the nominal conditions.</li> <li>⇒ The hot-gas bypass valve needs to be re-adjusted – contact a BEKO service technician to have the nominal setting re-established.</li> </ul>
◆ Extreme pressure drop in the dryer.	<ul style="list-style-type: none"> <li>⇒ The dryer does not discharge the condensate – see the corresponding point.</li> <li>⇒ The dew point is too low – the condensate is frozen and blocks the air – see the corresponding point.</li> </ul>

	⇒ Check the flexible connection hoses for obstructions.
◆ The dryer does not drain the condensate.	<ul style="list-style-type: none"> <li>⇒ The shut-off valve at the condensate outlet is closed – open it.</li> <li>⇒ Check the electric cabling.</li> <li>⇒ The dew point is too low – the condensate is frozen – see the corresponding point.</li> <li>⇒ The BEKOMAT condensate drain does not work properly (see BEKOMAT MANUAL).</li> </ul>
◆ Failure during the condensate discharge.	⇒ Please read the separate BEKOMAT installation and operating instructions.
◆ Water in the line.	<ul style="list-style-type: none"> <li>⇒ The dryer does not start – see the corresponding point.</li> <li>⇒ If installed - untreated air flows through the bypass unit – close the bypass.</li> <li>⇒ The dryer does not drain condensate – see the corresponding point.</li> <li>⇒ Dew point too high – see the corresponding point.</li> </ul>
◆ HPS high-pressure switch has triggered.	<ul style="list-style-type: none"> <li>⇒ Check which of the following reasons is responsible for the triggering:               <ol style="list-style-type: none"> <li>1. The ambient temperature is too high or the room ventilation insufficient – ensure sufficient ventilation (air-cooled).</li> <li>2. The condenser is dirty – please clean it (air-cooled).</li> <li>3. The condenser fan does not work – see the corresponding point (air-cooled).</li> <li>4. The cooling water is too hot – re-establish the nominal conditions (water-cooled).</li> <li>5. The cooling-water flow is insufficient – re-establish the nominal conditions (water-cooled).</li> </ol> </li> <li>⇒ Reset the pressure switch by pressing the button on the controller itself – check the proper functioning of the dryer.</li> <li>⇒ The HPS pressure switch is defective – contact a BEKO service technician for the replacement.</li> </ul>
◆ If installed: the LPS low-pressure switch was triggered.	<ul style="list-style-type: none"> <li>⇒ There is a leak in the refrigeration cycle – please contact a BEKO service technician.</li> <li>⇒ The pressure switch is automatically reset as soon as the normal conditions are re-established – check the dryer for proper functioning.</li> </ul>
◆ If installed: the TS safety temperature switch was triggered.	<ul style="list-style-type: none"> <li>⇒ Check which of the following reasons is responsible for the triggering:               <ol style="list-style-type: none"> <li>1. Excess thermal load – re-establish the standard operating conditions.</li> <li>2. The inlet air is too hot – re-establish the nominal conditions.</li> <li>3. The ambient temperature is too high or the room ventilation insufficient – ensure sufficient ventilation.</li> <li>4. The condenser unit is dirty – please clean it.</li> <li>5. The fan does not work – see the corresponding point.</li> <li>6. The hot-gas bypass valve needs to be re-adjusted – contact a specialist for refrigerating plants to have the nominal calibration re-established.</li> <li>7. The cooling-water temperature is too low – re-establish the nominal conditions (water-cooled).</li> <li>8. The adjusting valve for the cooling-water flow needs to be re-adjusted – contact a specialist to have the nominal calibration re-established (water-cooled).</li> <li>9. There is a leak in the refrigeration cycle – please contact a BEKO service technician.</li> </ol> </li> <li>⇒ Reset the temperature switch by manually pushing the button on the temperature switch – check the perfect functioning of the dryer.</li> <li>⇒ The TS temperature switch is defective – replace it.</li> </ul>
◆ DMC35 - Led ○  and display 1st (left) and 10th (right) led are flashing.	<ul style="list-style-type: none"> <li>⇒ Verify the electric wiring of BT1 DewPoint probe.</li> <li>⇒ The BT1 DewPoint probe is faulty - replace it.</li> <li>⇒ The electronic controller is faulty - replace it.</li> </ul>
◆ DMC35 - Leds ○  and ○  are flashing	<ul style="list-style-type: none"> <li>⇒ Verify the electric wiring of BT2 / BP2 fan control probe.</li> <li>⇒ The BT2 / BP2 fan control probe is faulty - replace it.</li> <li>⇒ The electronic controller is faulty - replace it.</li> </ul>
◆ DMC35 Led ○  and display 1st (left) led are flashing	<ul style="list-style-type: none"> <li>⇒ DewPoint too low - see specific point.</li> <li>⇒ The BT1 DewPoint probe is faulty - replace it.</li> <li>⇒ The electronic controller is faulty - replace it.</li> </ul>

- 
- ◆ DMC35  
The last led of the display is flashing

---

  - ◆ DMC34 – Led  is flashing + display **PF 1.**

---

  - ◆ DMC34 – Led  is flashing + display **PF2.**

---

  - ◆ DMC34 – Led  is flashing + display **HdP.**

---

  - ◆ DMC34 – Led  is flashing + display **LdP.**

---

  - ◆ DMC34 – Led  is flashing + display **SrL.**
- ⇒ DewPoint too high - see specific point.
  - ⇒ The BT1 DewPoint probe is faulty - replace it.
  - ⇒ The electronic controller is faulty - replace it.
- ⇒ Verify the electric wiring of BT1 DewPoint probe.
  - ⇒ The BT1 DewPoint probe is faulty - replace it.
  - ⇒ The electronic controller is faulty - replace it.
- ⇒ Verify the electric wiring of BP2 fan control probe.
  - ⇒ The BP2 fan control probe is faulty - replace it.
  - ⇒ The electronic controller is faulty - replace it.
- ⇒ DewPoint too high - see specific point.
  - ⇒ The BT1 DewPoint probe is faulty - replace it.
  - ⇒ The electronic controller is faulty - replace it.
- ⇒ DewPoint too low - see specific point.
  - ⇒ The BT1 DewPoint probe is faulty - replace it.
  - ⇒ The electronic controller is faulty - replace it.
- ⇒ Service reminder timer has expired – dryer requires service.
  - ⇒ Perform the proper service to the dryer.
  - ⇒ Reset the service reminder timer.



ID N.		DESCRIPTION	DP RS HP 3 PHASE				
			320	450	620	810	1010
2	LPS	Pressure switch	1	1	1	1	1
3	TS	Safety thermo switch	1	1	1	1	1
4	HPS	Pressure switch	1	1	1	1	1
37		Pressure transducer	1	1	1	1	1
6	MC	Compressor	1	1	1	1	1
7		Hot gas by-pass valve	1	1	1	1	1
8		Condenser	1	1	1	1	1
9	MV	Complete fan	1	1	1	1	1
10		Filter drier	1	1	1	1	1
12	BT	Temperature probe	1	1	1	1	1
17	DMC34	Electronic instrument	1	1	1	1	1
19		Water regulating valve (water cooled)	1	1	1	1	1
21	ELD	Electronic drainer	1	1	1	1	1
		Service unit for electronic drainer	1	1	1	1	1
22	S1	Lighted switch	1	1	1	1	1
	QS	Main switch	1	1	1	1	1
60	FU	Fuse kit	1	1	1	1	1
	KC1-KV1	Contacteur	2	2	2	2	2
	TF	Transformer	1	1	1	1	1

## 12.4 Maintenance works at the refrigeration cycle



### Caution! Refrigerant!

Maintenance and repair works at refrigeration systems must only be carried out by BEKO service technicians in accordance with the local provisions.

The total amount of refrigerant in the system must be collected for recycling purposes, resource recovery or disposal.

**The refrigerant must not be discharged into the environment.**

When delivered, the dryer is ready to operate and filled with a refrigerant of the R134a or R407C type.



Should you detect a refrigerant leak, please contact a BEKO service technician. Prior to any intervention, the room needs to be ventilated.

When the refrigeration cycle needs to be refilled, please also contact a BEKO service technician.

You will find the refrigerant type and amount on the name plate of the dryer.

Properties of the refrigerants used:

Refrigerant	Chemical formula	MIK	GWP
R134a - HFC	CH <sub>2</sub> FCF <sub>3</sub>	1000 ppm	1430
R407C - HFC	R32/125/134a (23/25/52) CHF <sub>2</sub> CF <sub>3</sub> /CH <sub>2</sub> F <sub>2</sub> /CH <sub>2</sub> FCF <sub>3</sub>	1000 ppm	1773,85

## 12.5 Dismantling the dryer

When the dryer is dismantled, all parts and operating materials related to the plant need to be disposed of separately.



Part	Material
Refrigerant fluid	R407C, R134a, Oil
Canopy and supports	Carbon steel, Epoxy paint
Refrigerating compressor	Steel, Copper, Aluminium, Oil
Heat exchanger	Stainless steel, Copper
Condensate separator	Stainless steel
Condenser unit	Aluminium, Copper, Carbon steel
Pipe	Copper
Fan	Aluminium, Copper, Steel
Valve	Brass, Steel
Electronic level drain	PVC, Aluminium, Steel
Insulation material	Synthetic rubber without CFC, Polystyrene, Polyurethane
Electric cable	Copper, PVC
Electric parts	PVC, Copper, Brass



We recommend observing the safety provisions in force for the disposal of each material type.  
The refrigerant contains lubricating-oil droplets which are released by the compressor.  
The refrigerant must not be discharged into the environment. It must to be sucked off from the dryer using a suitable device, and then needs to be supplied to a collection point.

## 13 Appendices

### 13.1 Dryer dimensions

13.1.1 Dryer dimensions DRYPOINT RS 25-70 HP50

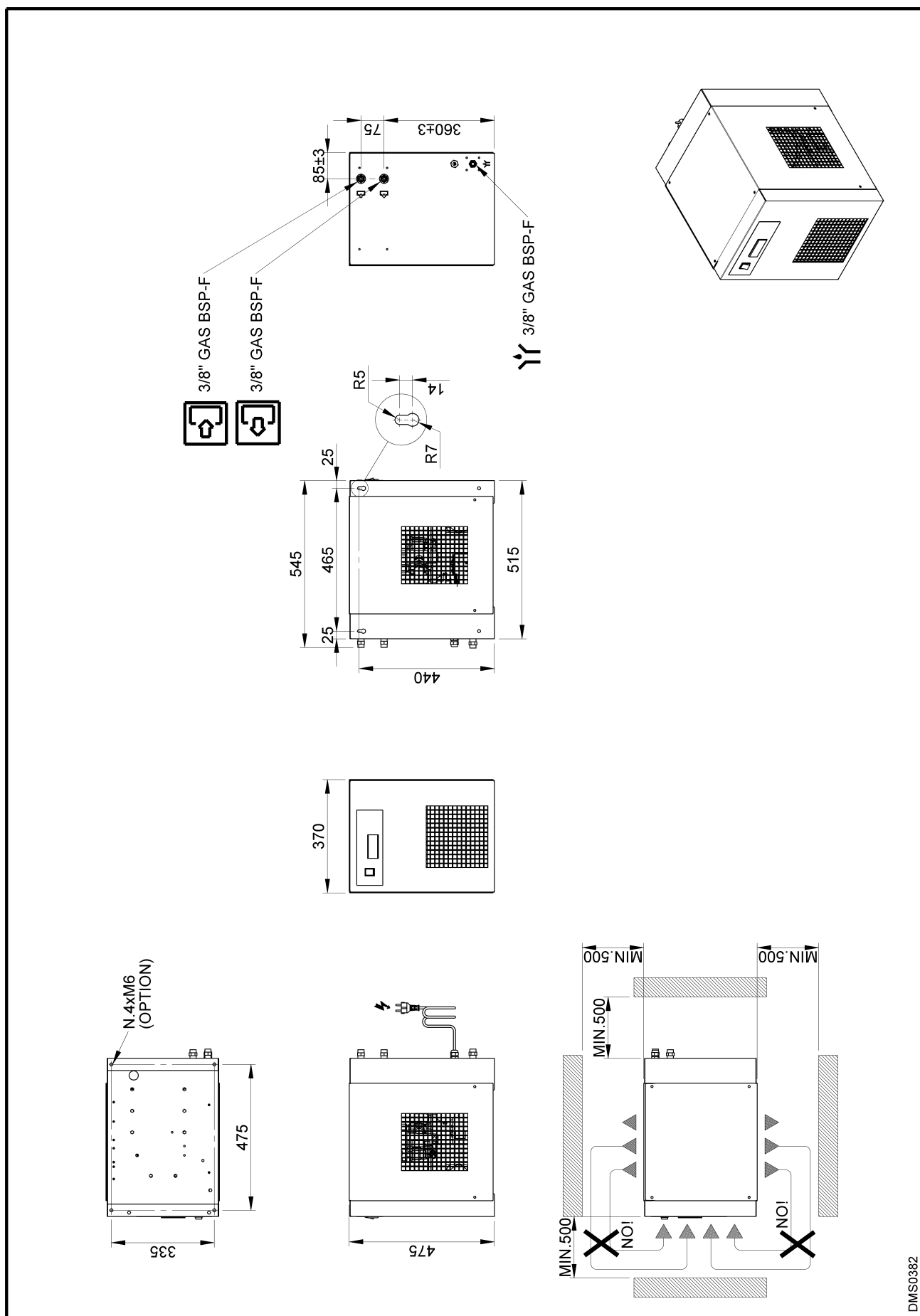

DIMS0382

**13.1.2 Dryer dimensions DRYPOINT RS 90-135 HP50**

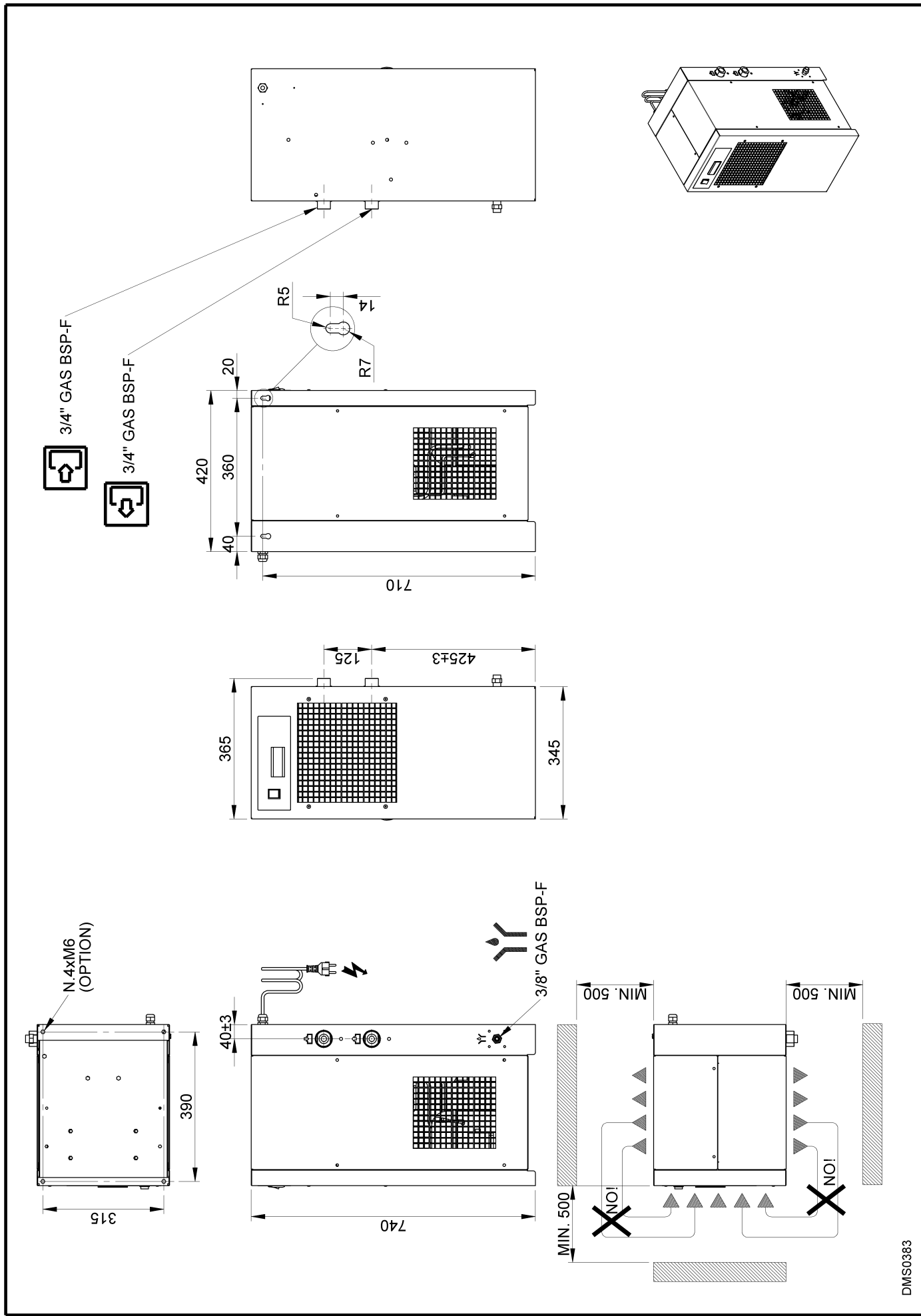

DMS0383

**13.1.3 Dryer dimensions DRYPOINT RS 180-240 HP50**

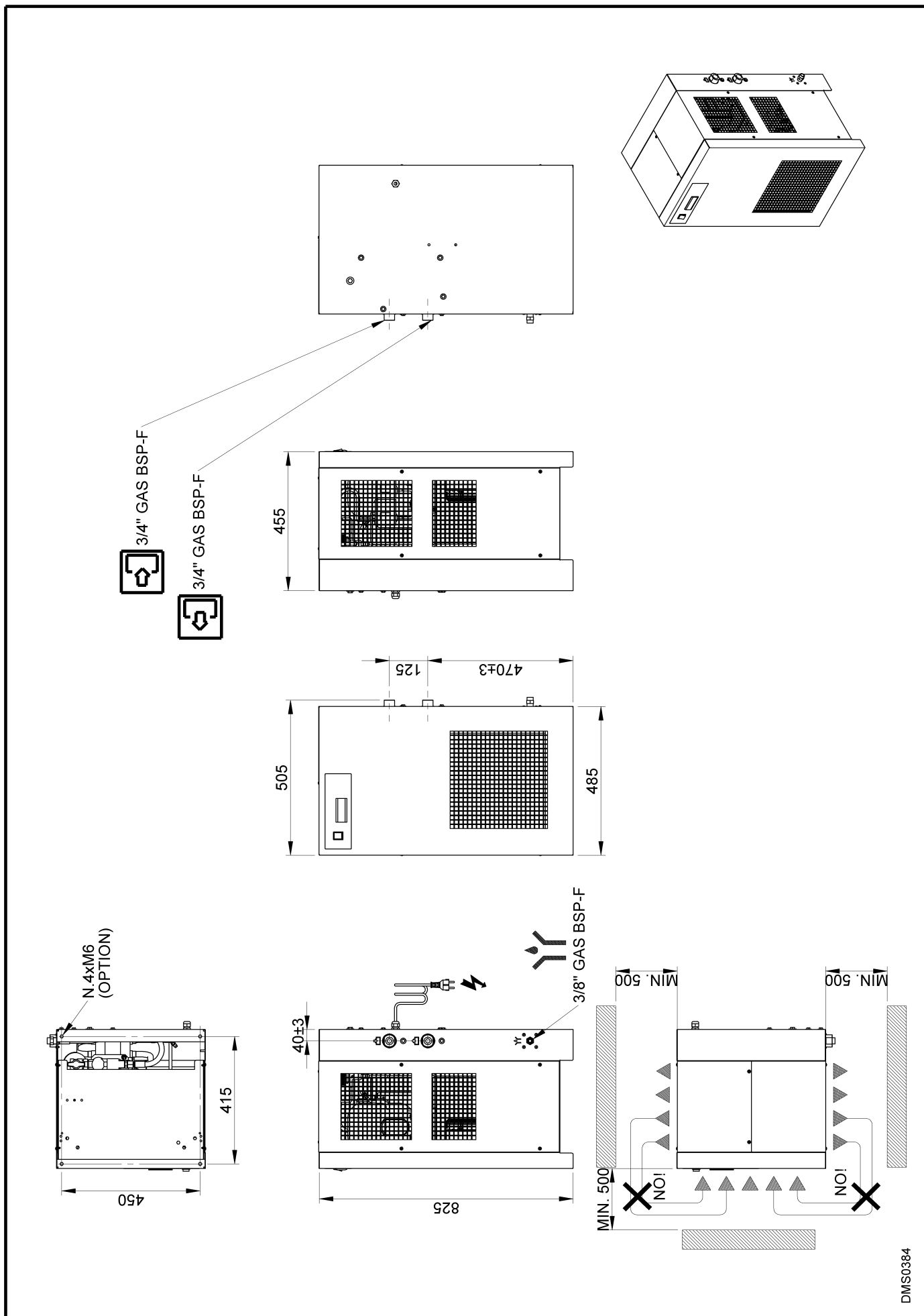

DMS0384

**13.1.4 Dryer dimensions DRYPOINT RS 320-620 HP50**

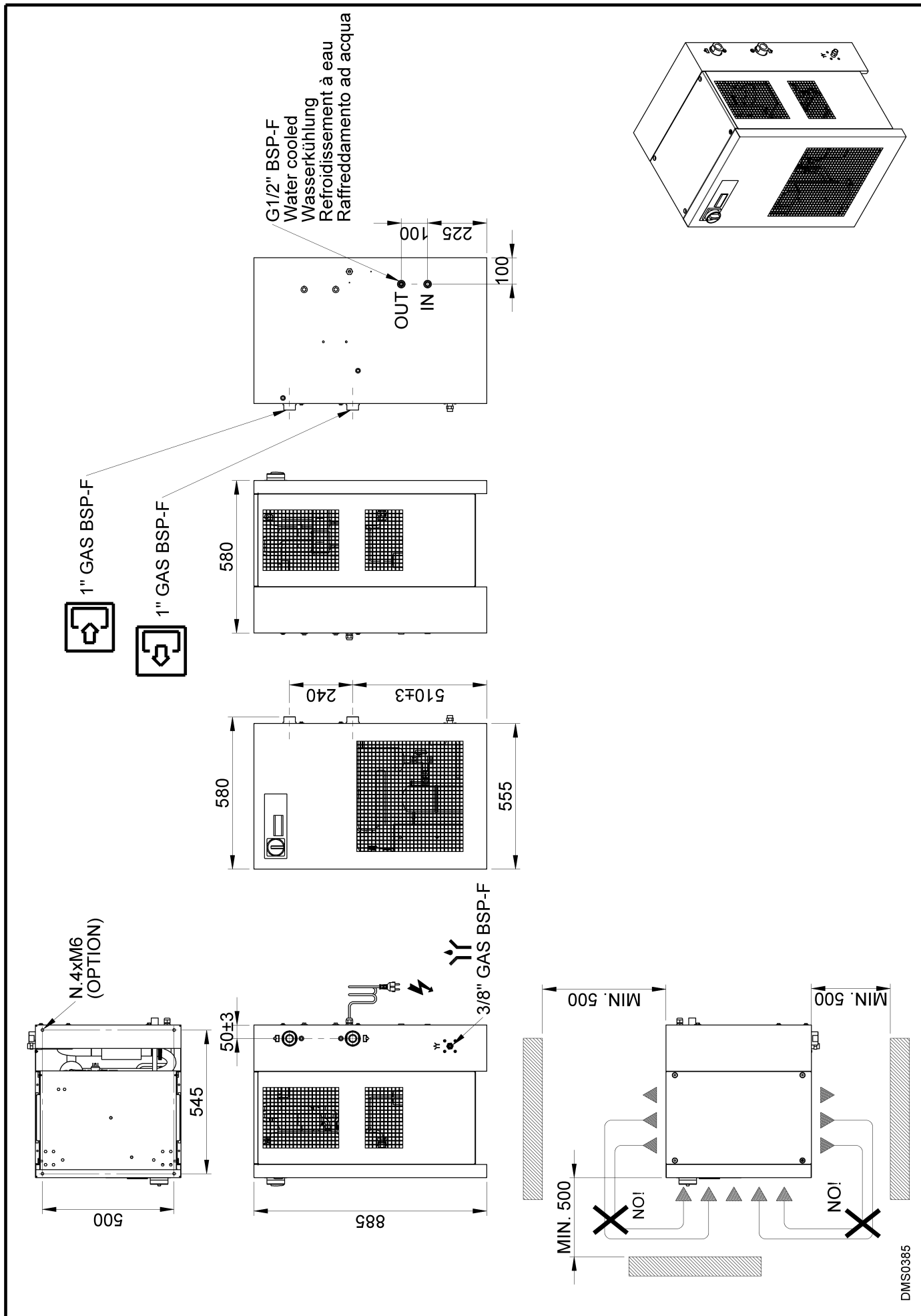

**13.1.5 Dryer dimensions DRYPOINT RS 810-1010 HP50**

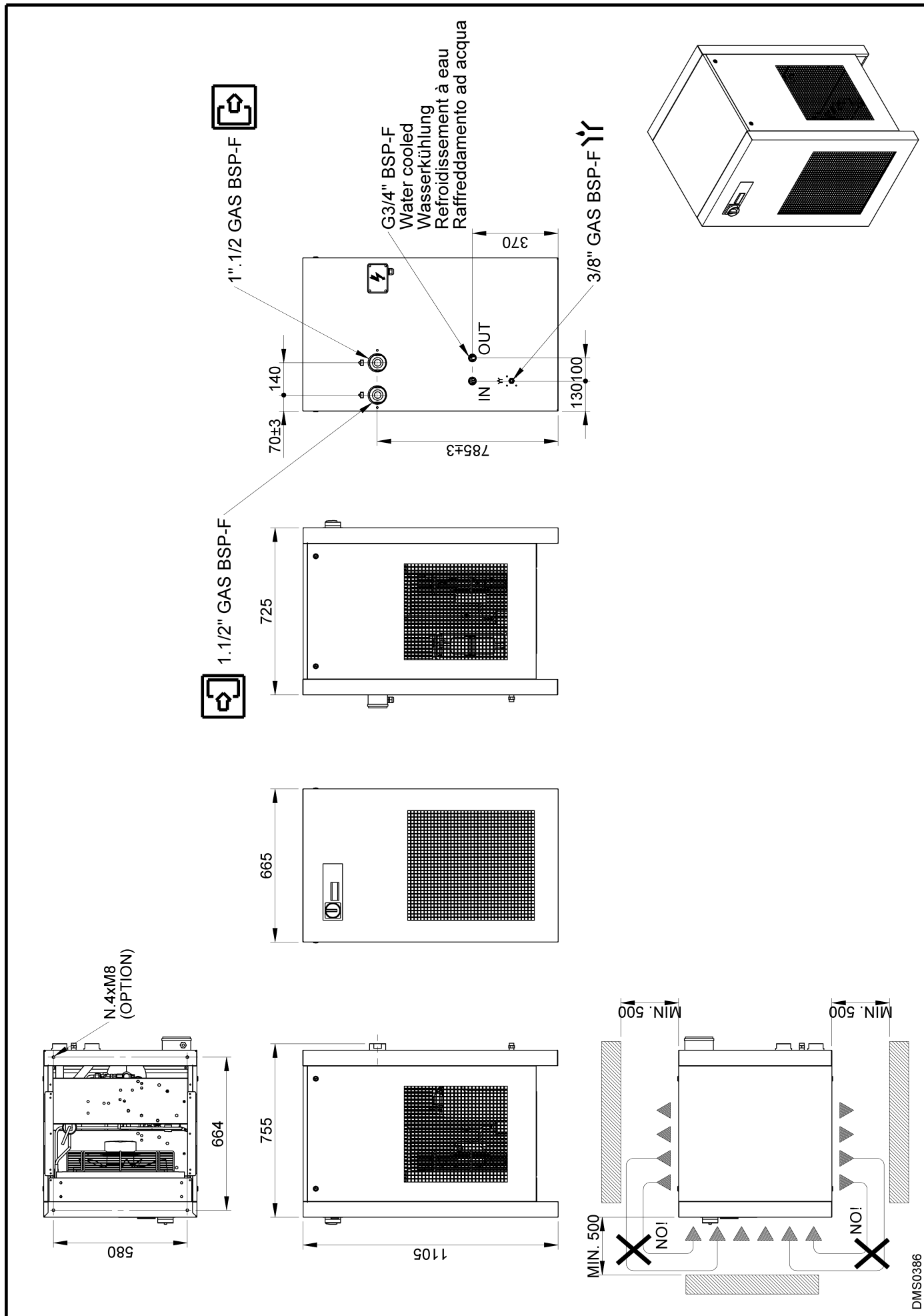

**13.1.6 Dryer dimensions DRYPOINT RS 320-620 HP50 3phase**

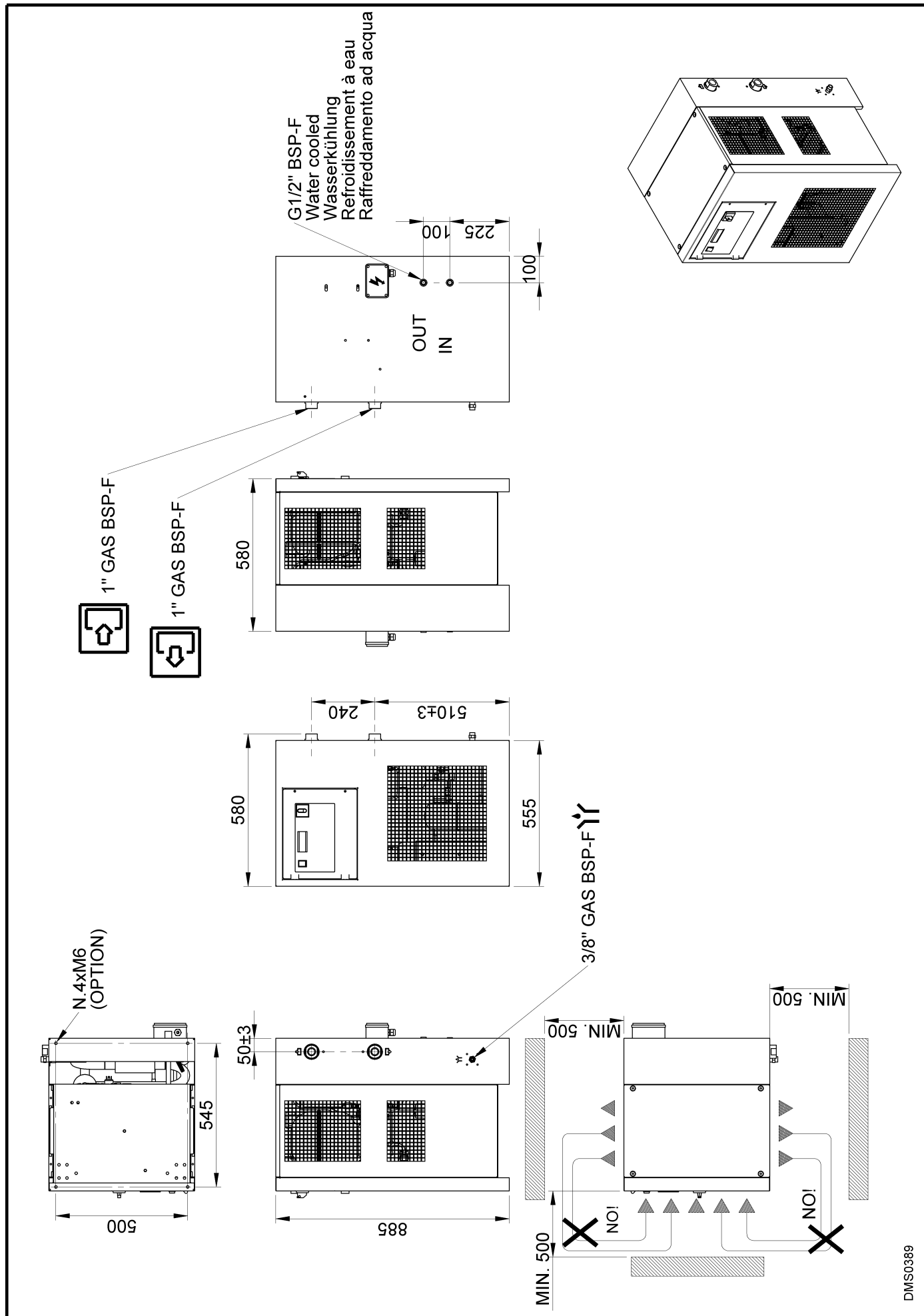

DMS0389

**13.1.7 Dryer dimensions DRYPOINT RS 810-1010 HP50 3phase**

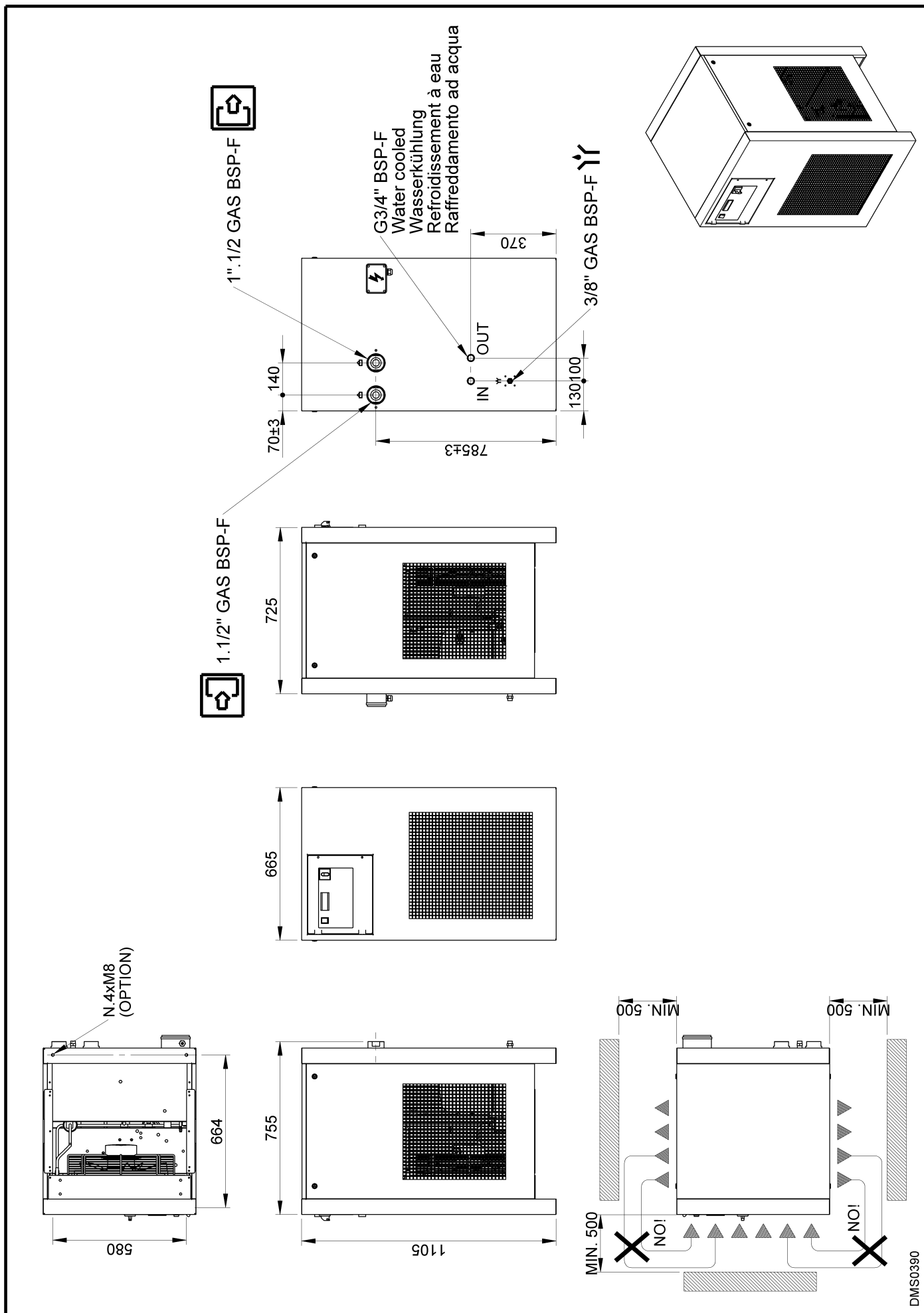

## 13.2 Exploded diagrams

### 13.2.1 Components of the exploded diagrams

<b>1</b>	Heat exchanger group	<b>20</b>	Refrigerant reservoir (water-cooled)
	c – Condensate separator	<b>21</b>	Bekomat drain
<b>2</b>	Refrigerant pressure switch LPS	<b>22</b>	Main switch
<b>3</b>	Safety temperature switch TS	<b>37</b>	Pressure transducer BP2
<b>4</b>	Refrigerant pressure switch HPS	<b>51</b>	Front panel
<b>6</b>	Compressor	<b>52</b>	Back plate
<b>7</b>	Hot-gas bypass valve	<b>53</b>	Right sidewall
<b>8</b>	Condenser (air-cooled)	<b>54</b>	Left sidewall
<b>9</b>	Condenser fan	<b>55</b>	Cover
	<b>9.1</b> Motor	<b>56</b>	Base plate
	<b>9.2</b> Blade	<b>57</b>	Upper plate
	<b>9.3</b> Grid	<b>58</b>	Carrier support
<b>10</b>	Filter dryer	<b>59</b>	Support bracket
<b>11</b>	Capillary tube	<b>60</b>	Control panel
<b>12</b>	T1 temperature probe (dew point)	<b>61</b>	Electric connecting plug
<b>13</b>	Condensate drain service valve	<b>62</b>	Electric cabinet
<b>17</b>	Air dryer control	<b>65</b>	Condenser filter
<b>18</b>	Condenser (water-cooled)	<b>66</b>	QE door
<b>19</b>	Condenser water-regulating valve (water-cooled)	<b>81</b>	Adhesive label flow chart

13.2.2 Exploded diagram DRYPOINT RS 25-70 HP50 / AC

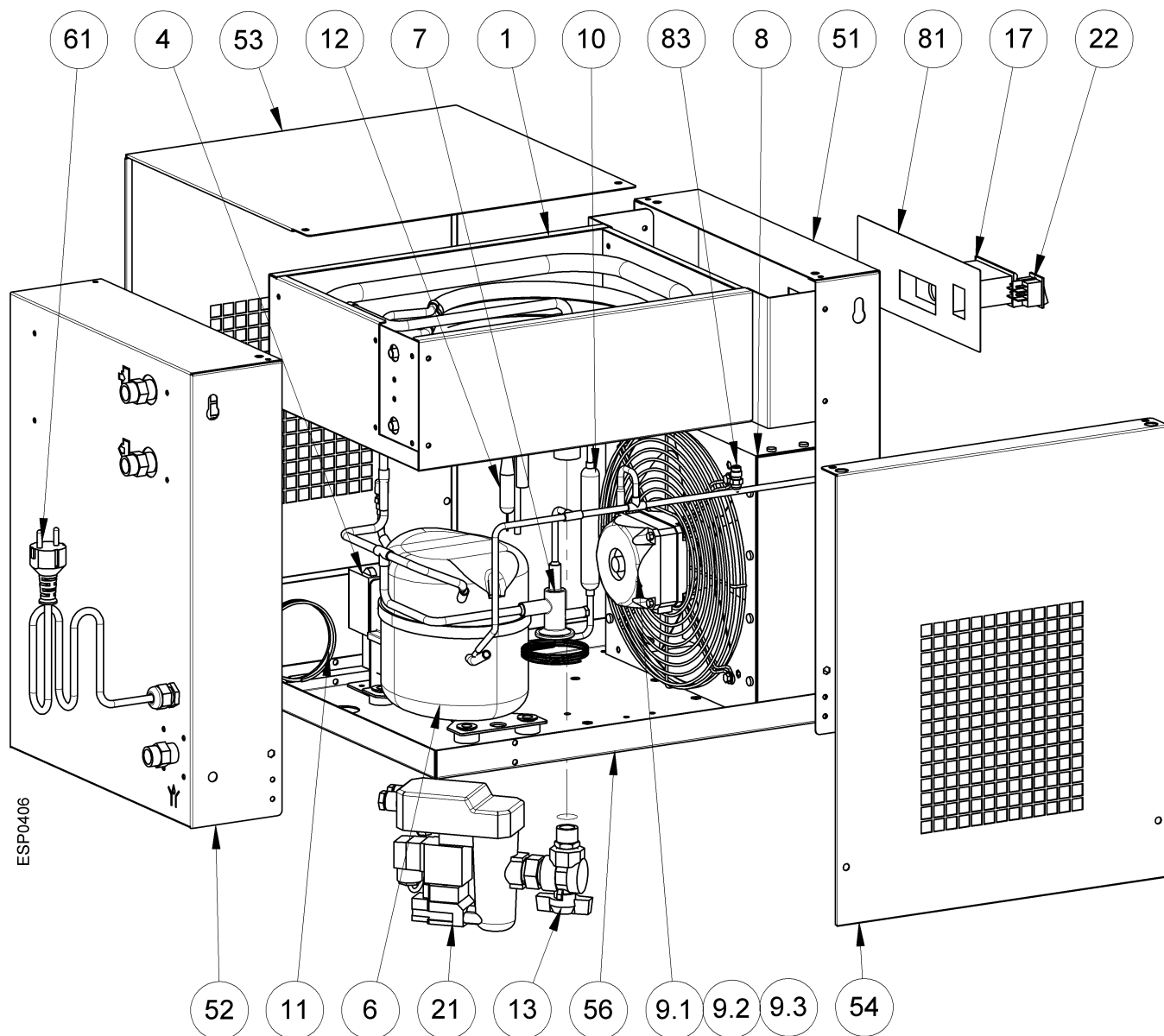

13.2.3 Exploded diagram DRYPOINT RS 90-135 HP50 / AC

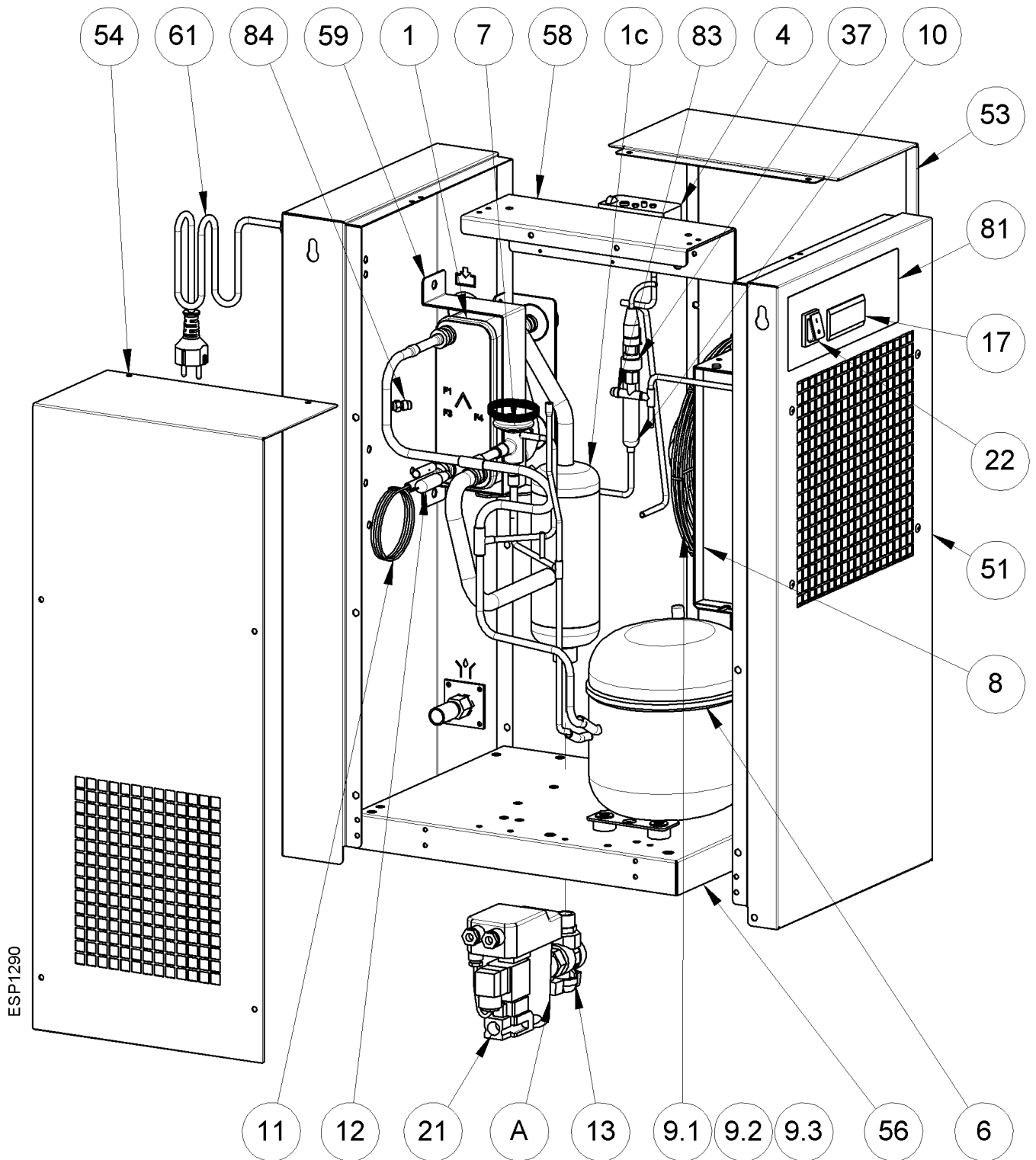



13.2.5 Exploded diagram DRYPOINT RS 320-620 HP50 / AC

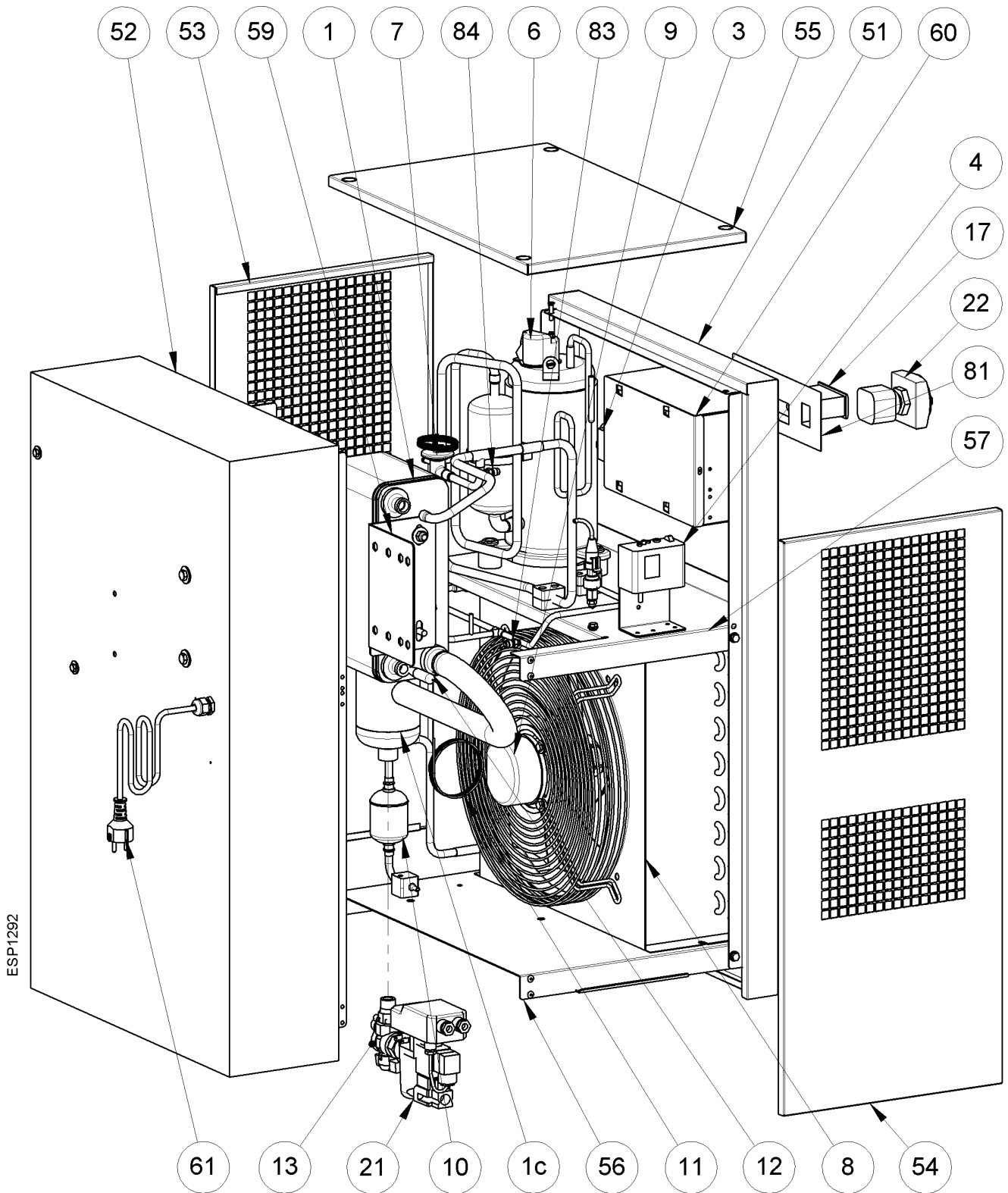

13.2.6 Exploded diagram DRYPOINT RS 810-1010 HP50 / AC

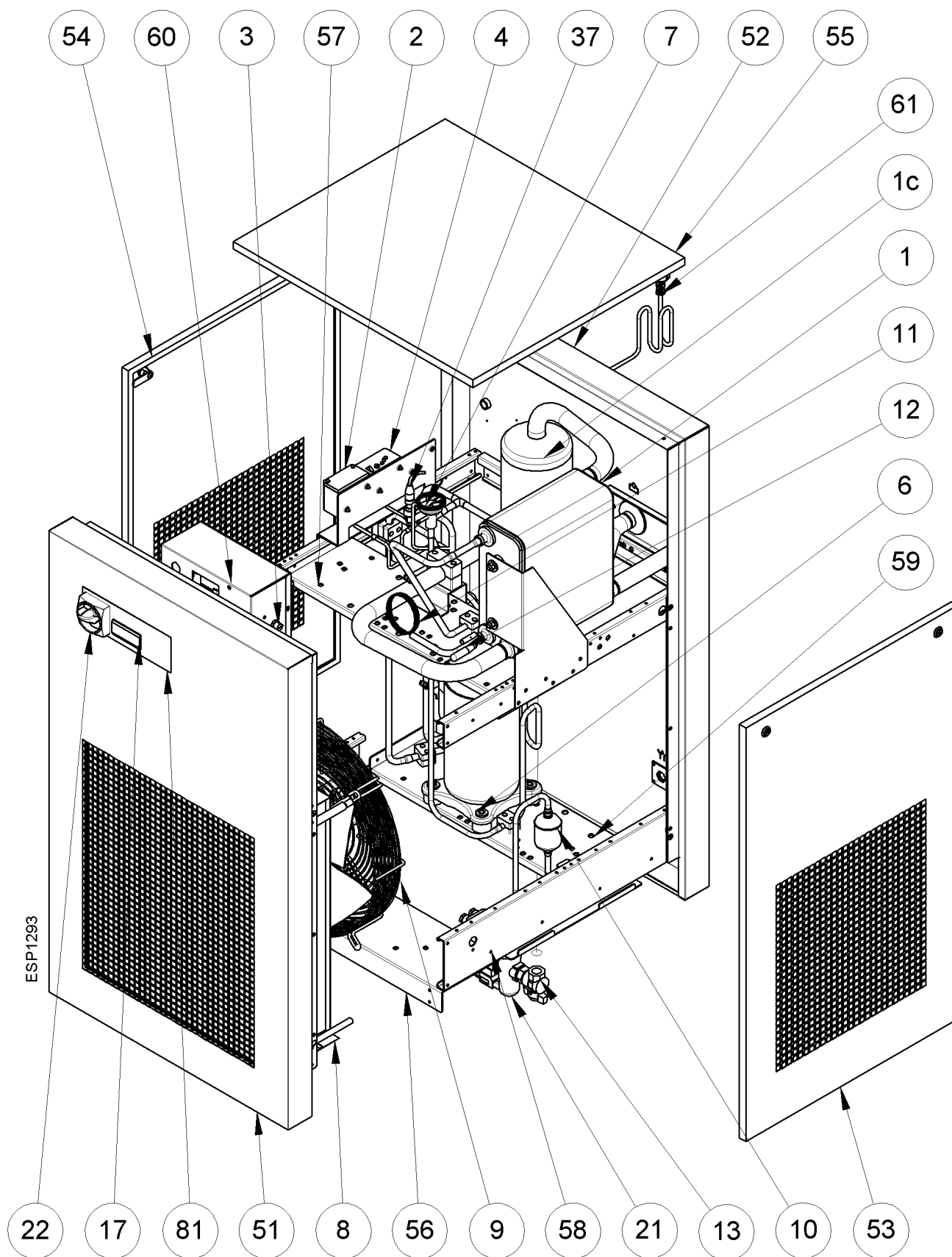

13.2.7 Exploded diagram DRYPOINT RS 320-620 HP50 / WC

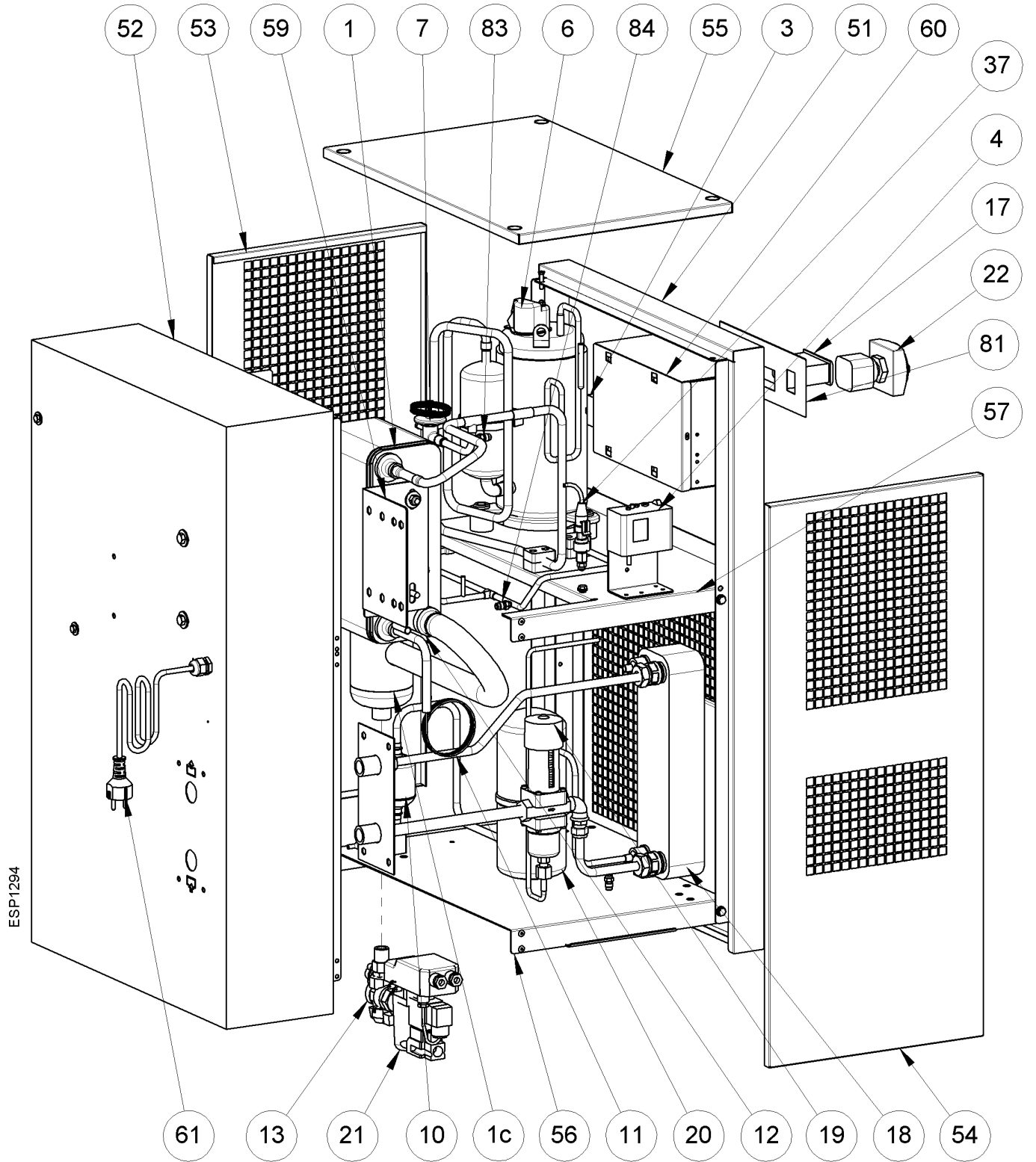

13.2.8 Exploded diagram DRYPOINT RS 810-1010 HP50 / WC

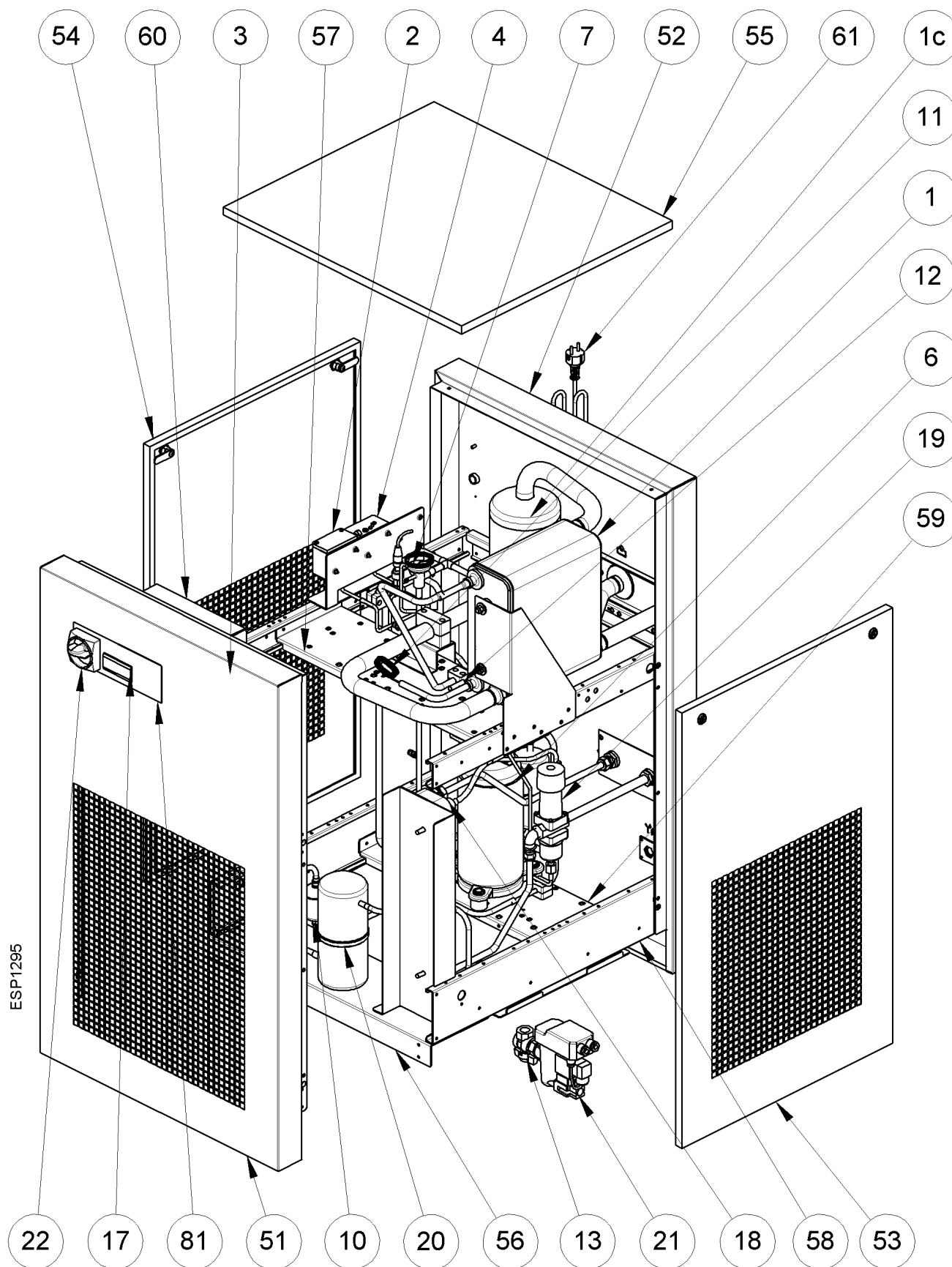

13.2.9 Exploded diagram DRYPOINT RS 320-620 HP50 3phase / AC

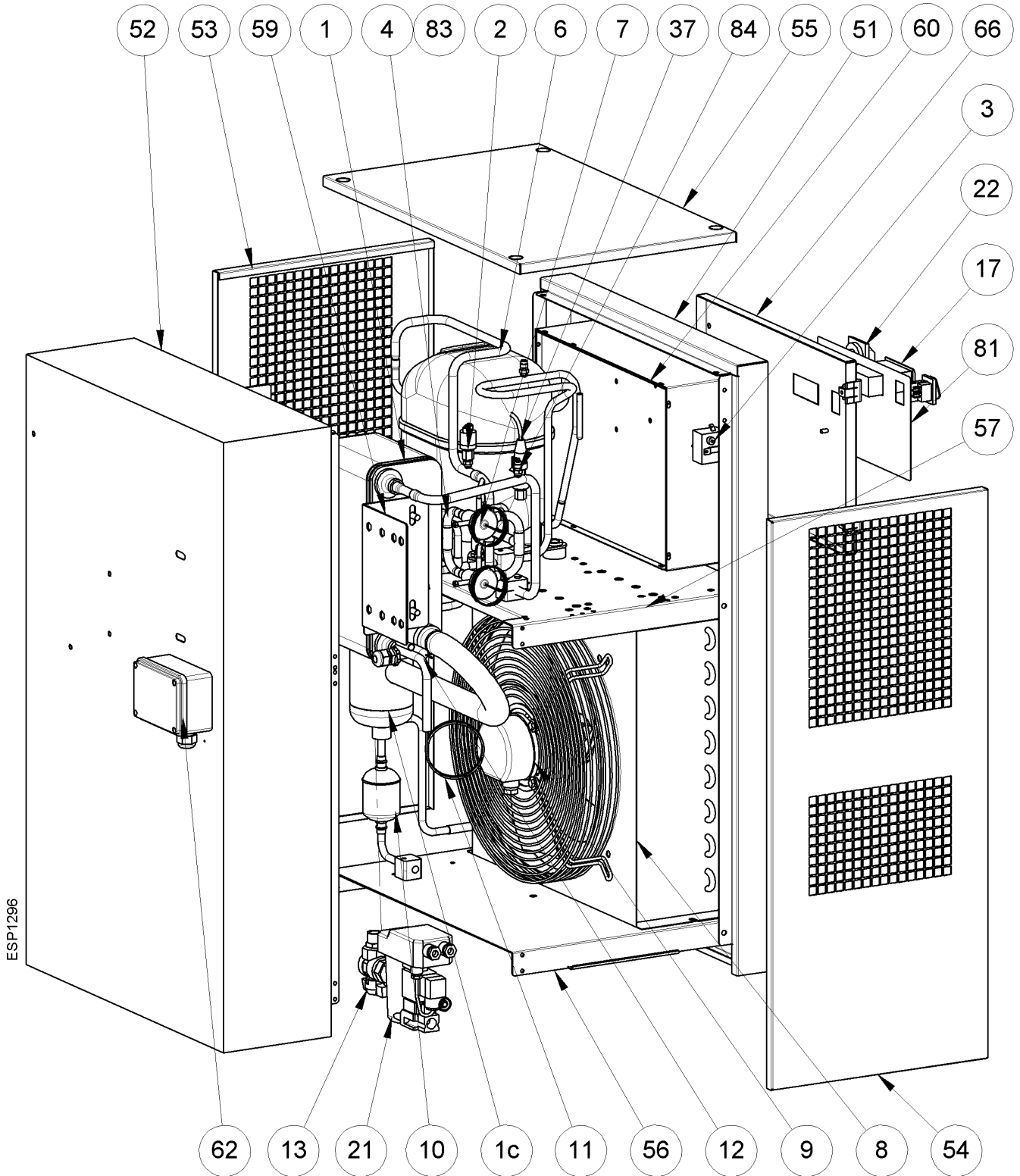

13.2.10 Exploded diagram DRYPOINT RS 810-1010 HP50 3phase / AC

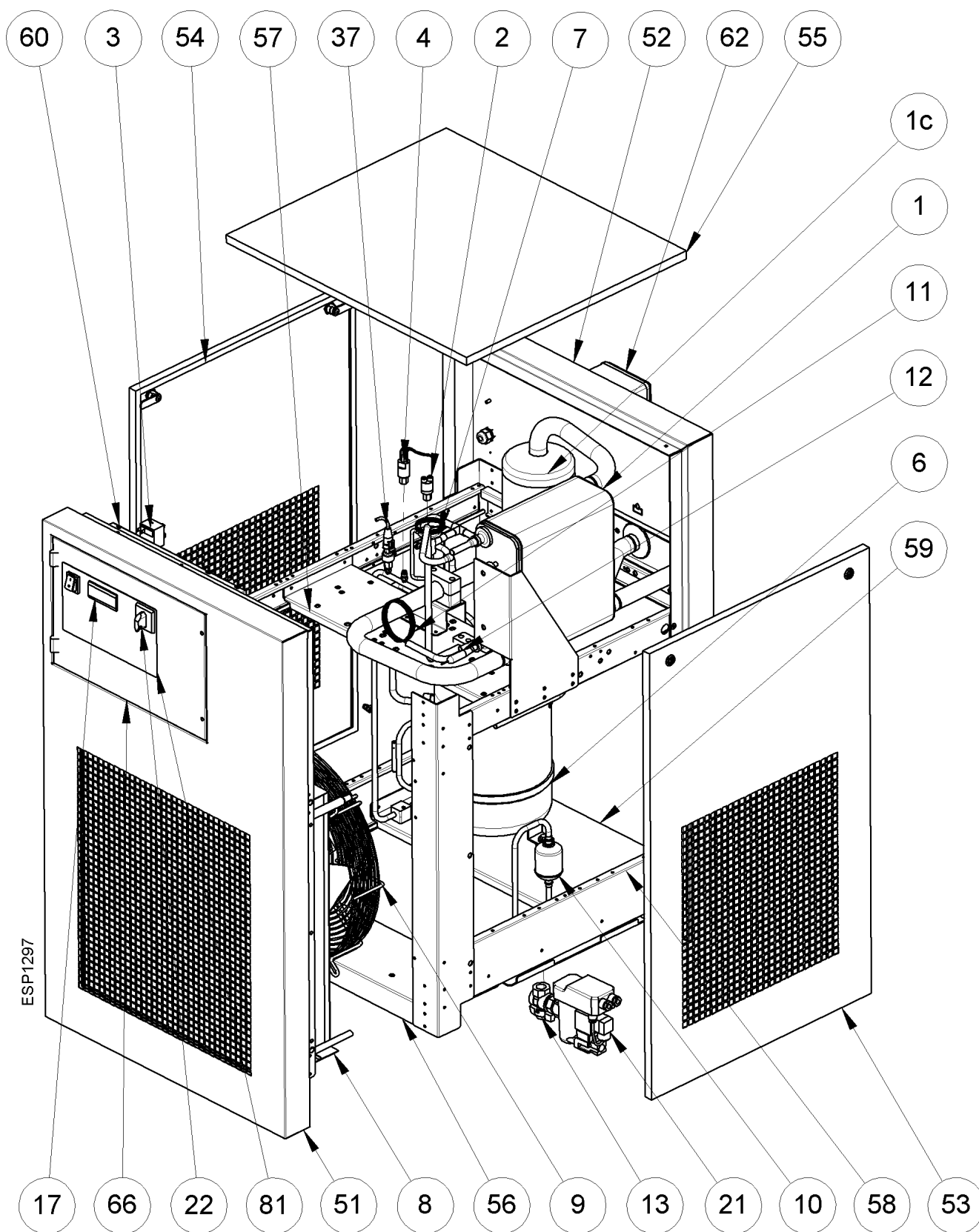

13.2.11 Exploded diagram DRYPOINT RS 320-620 HP50 3phase / WC

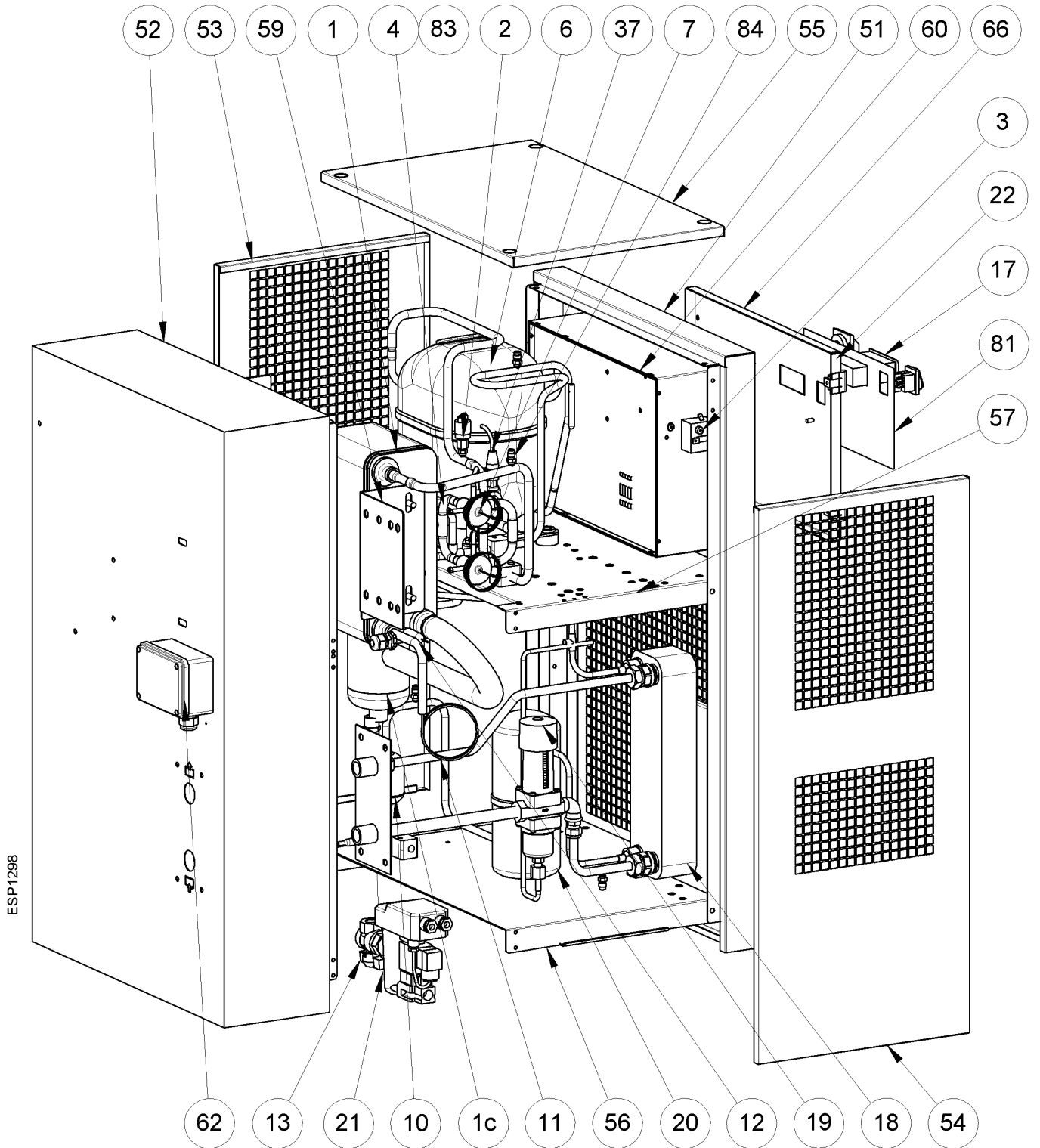

13.2.12 Exploded diagram DRYPOINT RS 810-1010 HP50 3phase / WC

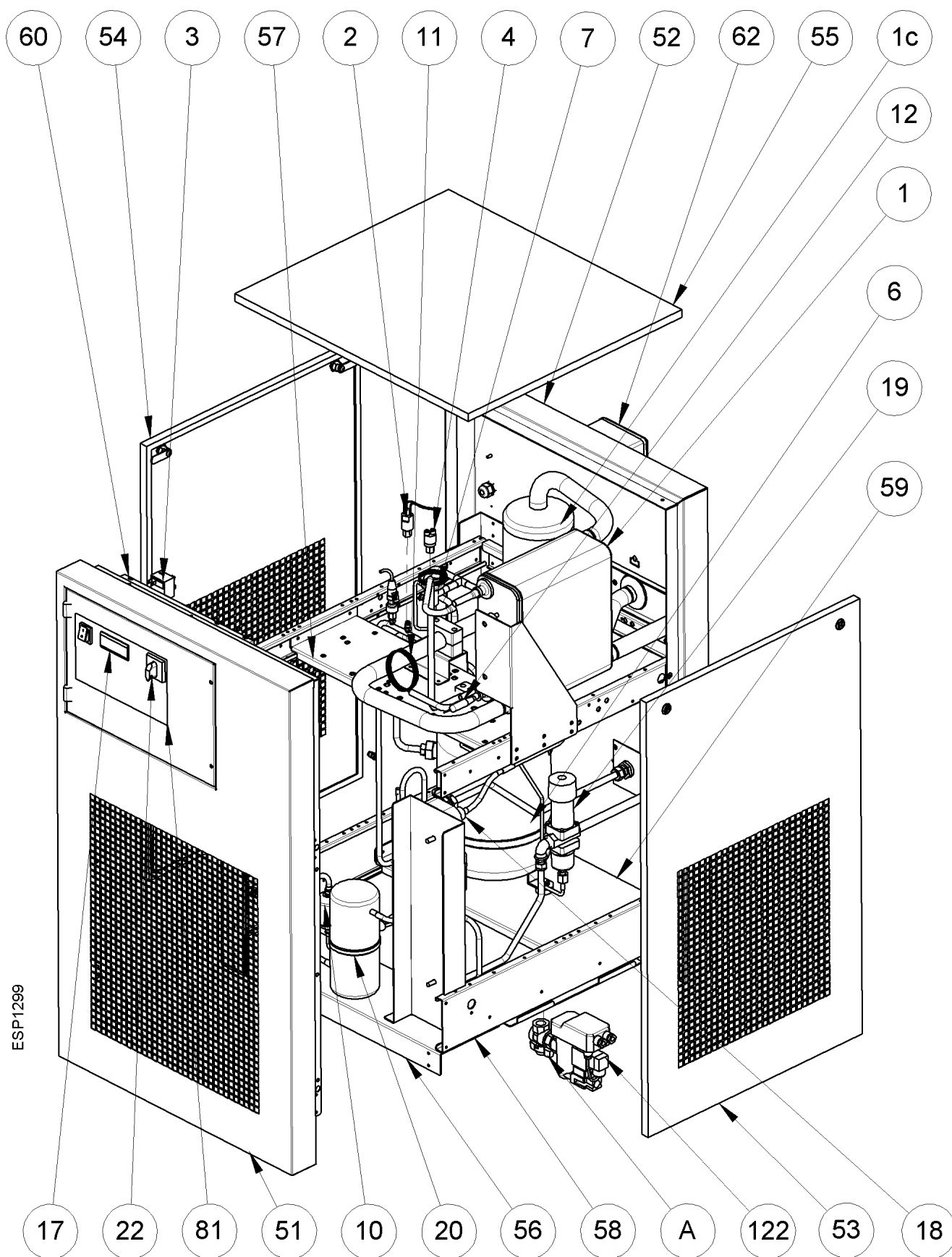

### 13.3 Electric diagrams

#### 13.3.1 Electric diagrams – list of components

<b>MC</b>	:	Compressor		
		<b>KT</b>	:	Compressor thermal protection
		<b>KR</b>	:	Compressor starting relay (if installed)
		<b>CS</b>	:	Compressor starting capacitor (if installed)
		<b>CR</b>	:	Compressor operating capacitor (if installed)
<b>MV</b>	:	Condenser fan		
		<b>CV</b>	:	Fan starting capacitor (if installed)
<b>DMC35</b>	:	DMC35 electronic instrument – air dryer control		
		<b>BT1</b>	:	T1 Temperature probe – dew point
		<b>BT2</b>	:	T2 Temperature probe – fan control
<b>DMC34</b>	:	DMC14 Electronic Instrument - Air Dryer Controller		
		<b>BT1</b>	:	T1 Temperature probe – dew point
		<b>BP2</b>	:	Pressure transducer - fan control
<b>HPS</b>	:	Pressure switch – compressor discharge side (HIGH PRESSURE)		
<b>LPS</b>	:	Pressure switch – compressor suction side (LOW PRESSURE)		
<b>TS</b>	:	Safety temperature switch		
<b>ELD</b>	:	BEKOMAT drain		
<b>S1</b>	:	ON/OFF switch		
<b>QS</b>	:	Main switch with locking device		
<b>RC</b>	:	Compressor crankcase heater		
<b>BOX</b>	:	Electrical connection		
<b>NT1</b>	:	Only air-cooled		
<b>NT2</b>	:	Check the transformer connections with regard to the supply voltage		
<b>NT3</b>	:	Jump, if not installed		
<b>NT4</b>	:	Provided and cabled by the customer		
<b>NT5</b>	:	Internal control		
<b>NT6</b>	:	Time-controlled drain outlet (not used)		
<b>NT7</b>	:	Only water-cooled		
<b>BN</b>	=	BROWN	<b>OR</b>	= ORANGE
<b>BU</b>	=	BLUE	<b>RD</b>	= RED
<b>BK</b>	=	BLACK	<b>WH</b>	= WHITE
<b>YG</b>	=	YELLOW/GREEN	<b>WH/BK</b>	= WHITE/BLACK

13.3.2 Electric diagram DRYPOINT RS 25-70 HP50

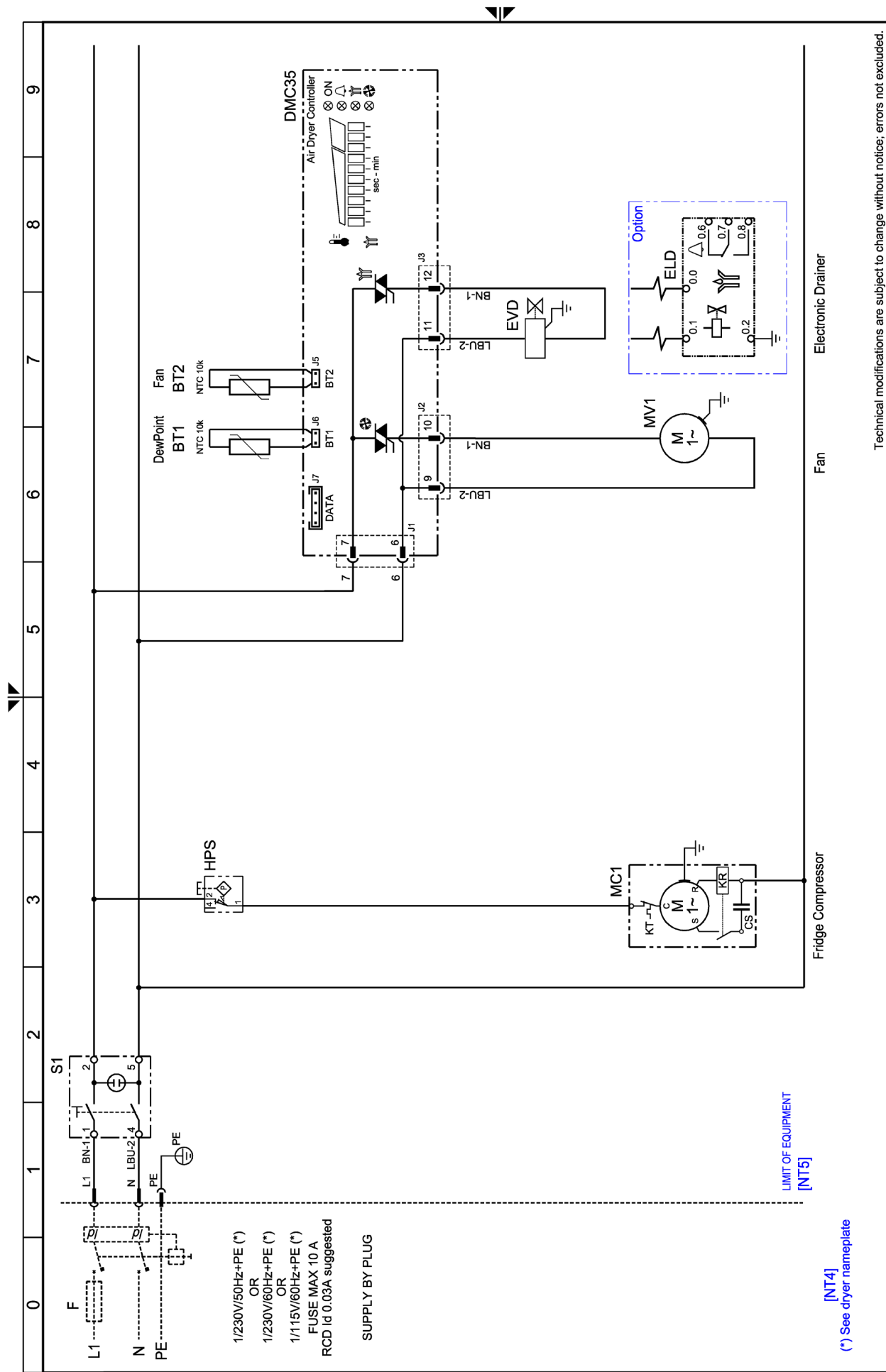

Technical modifications are subject to change without notice; errors not excluded.  
 Drawing no. : WD001\_V11  
 Rev. 00  
 Note : .  
 Sheet 01 of 01

**13.3.3 Electric diagram DRYPOINT RS 90-135 HP50**

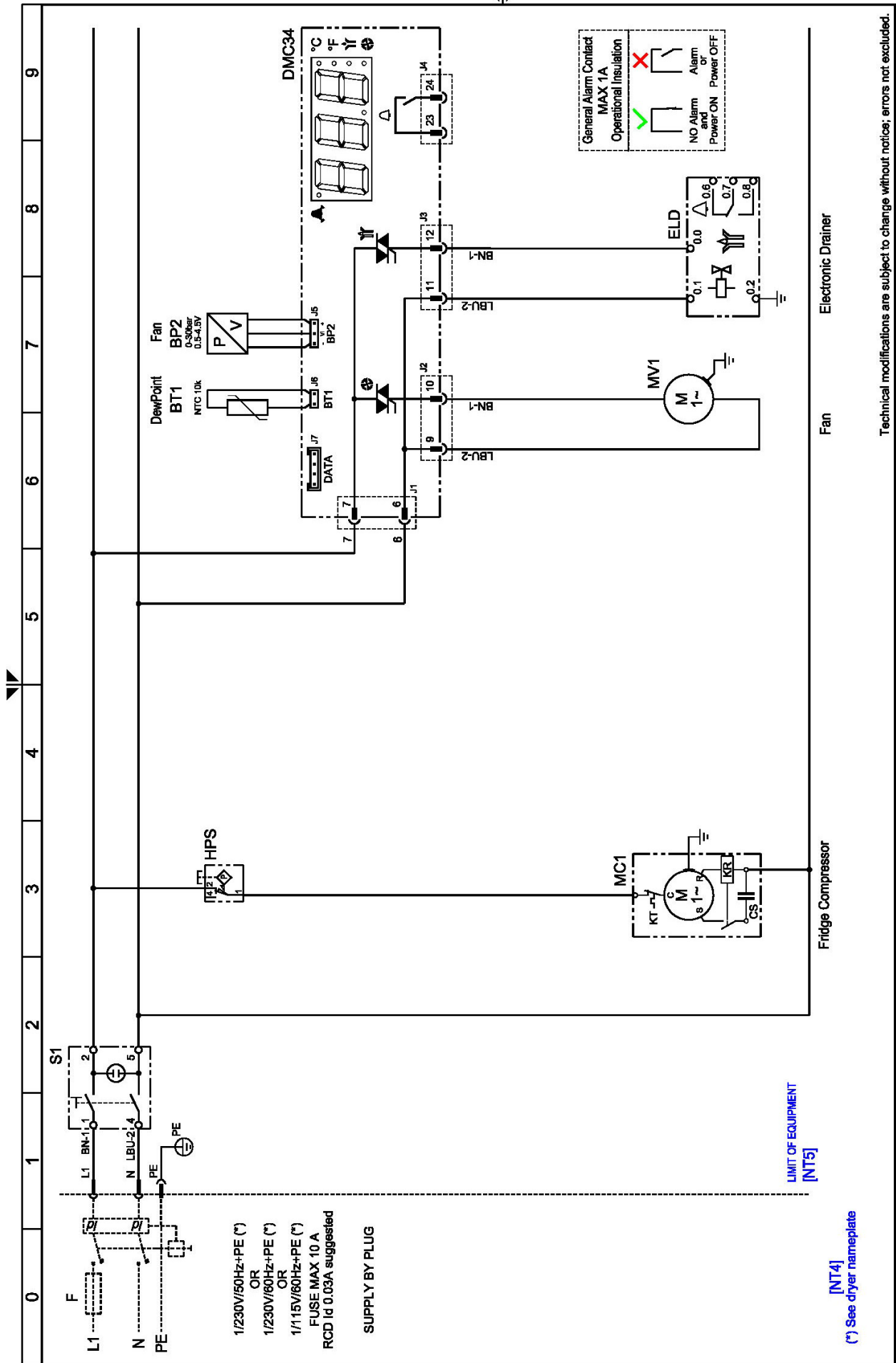

Technical modifications are subject to change without notice; errors not excluded.

Drawing no.: **WD016\_V02**  
 Rev. **00**

Note: -

Sheet **01** of **01**

13.3.4 Electric diagram DRYPOINT RS 180-240 HP50

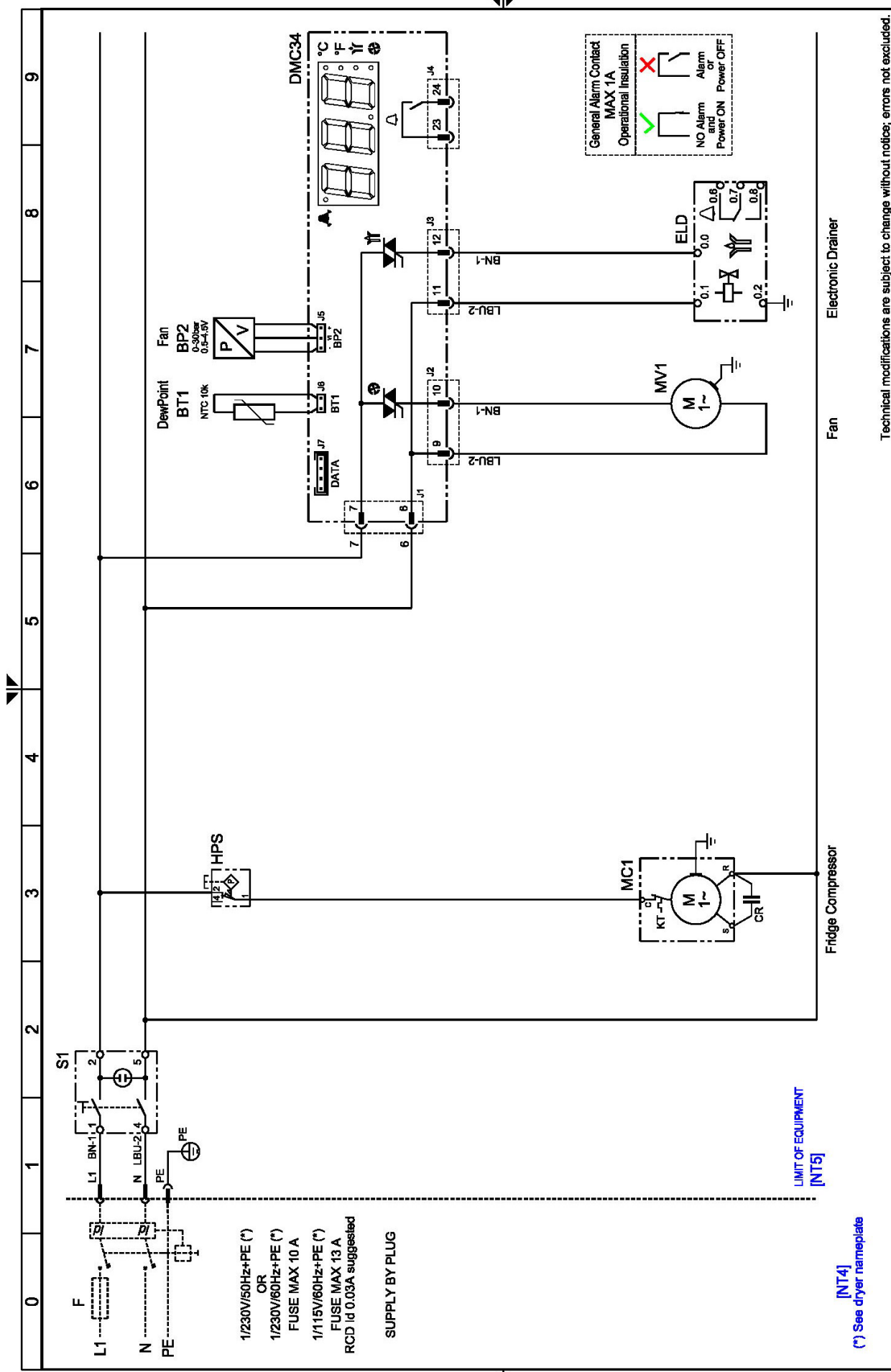

Technical modifications are subject to change without notice; errors not excluded.

Rev.

00

WD017\_V02

Note :

Sheet 01 of 01

13.3.5 Electric diagram DRYPOINT RS 320-450 HP50

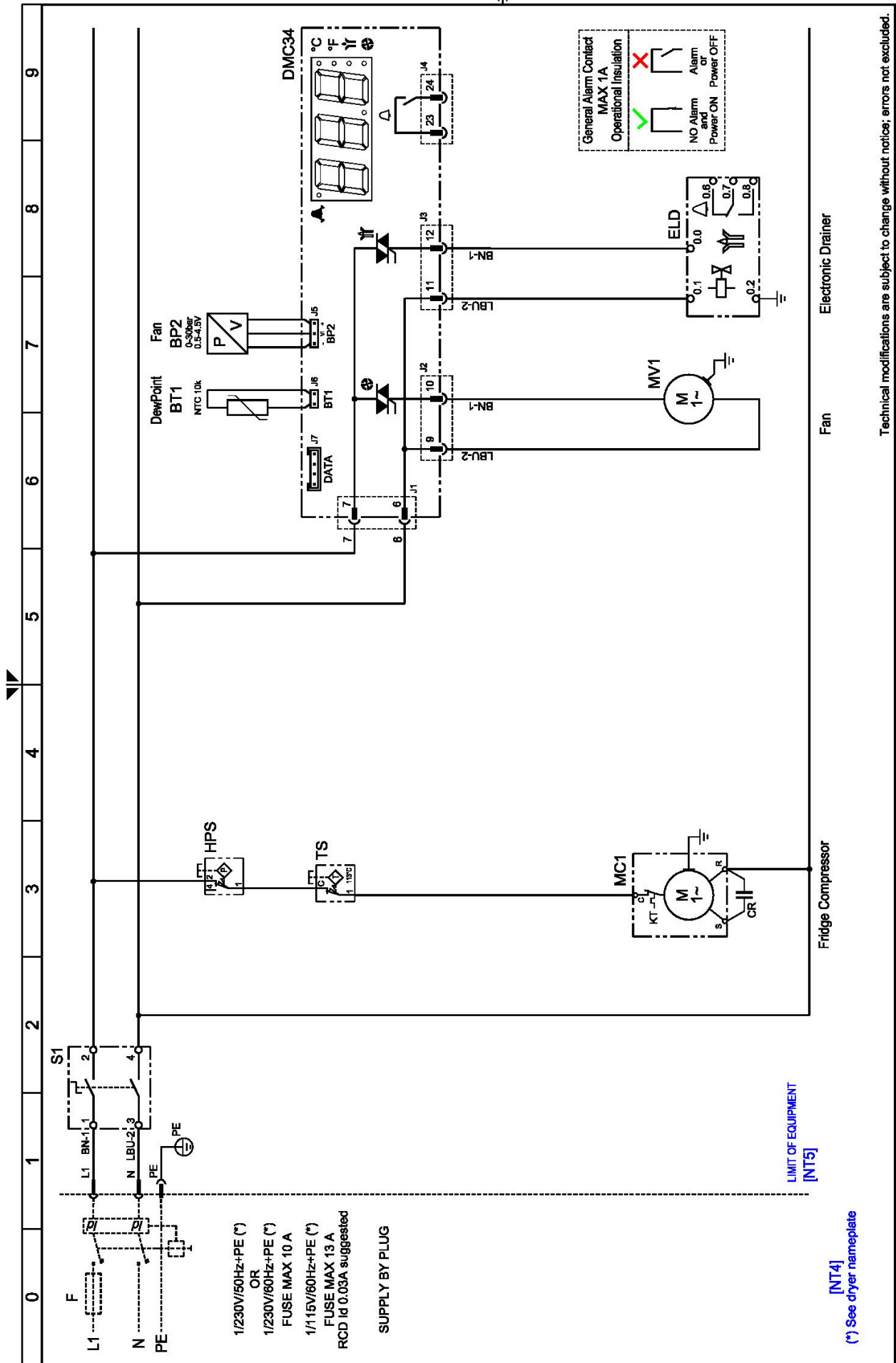

Technical modifications are subject to change without notice; errors not excluded.

Drawing no. : WD018\_V02

Rev. 00

Note : -

Sheet 01 of 01

**13.3.6 Electric diagram DRYPOINT RS 620 HP50**

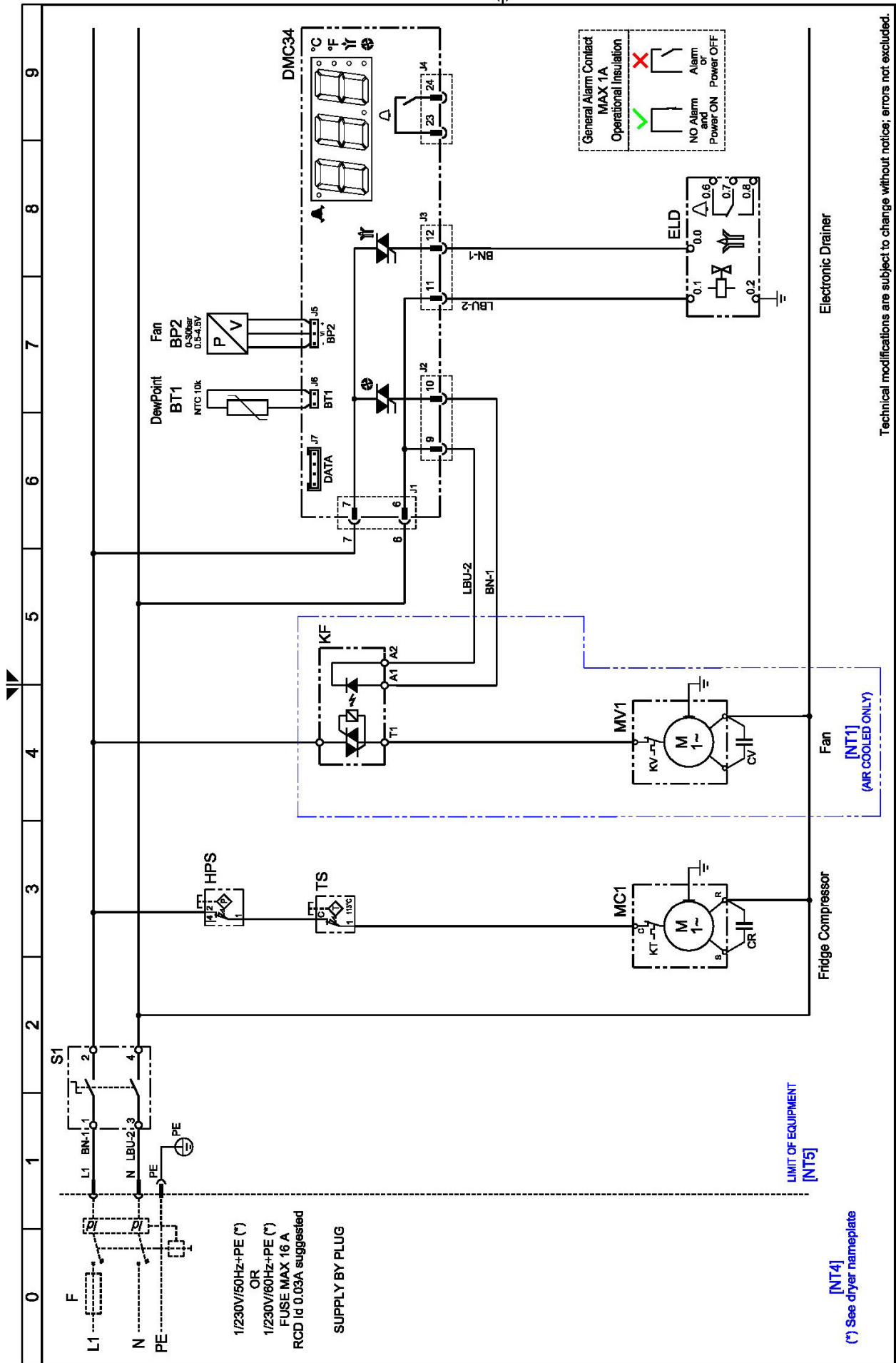

Technical modifications are subject to change without notice; errors not excluded.

Rev. 00

Drawing no. : WD019\_V02

Note :

Sheet 01 of 01

13.3.7 Electric diagram DRYPOINT RS 810-1010 HP50

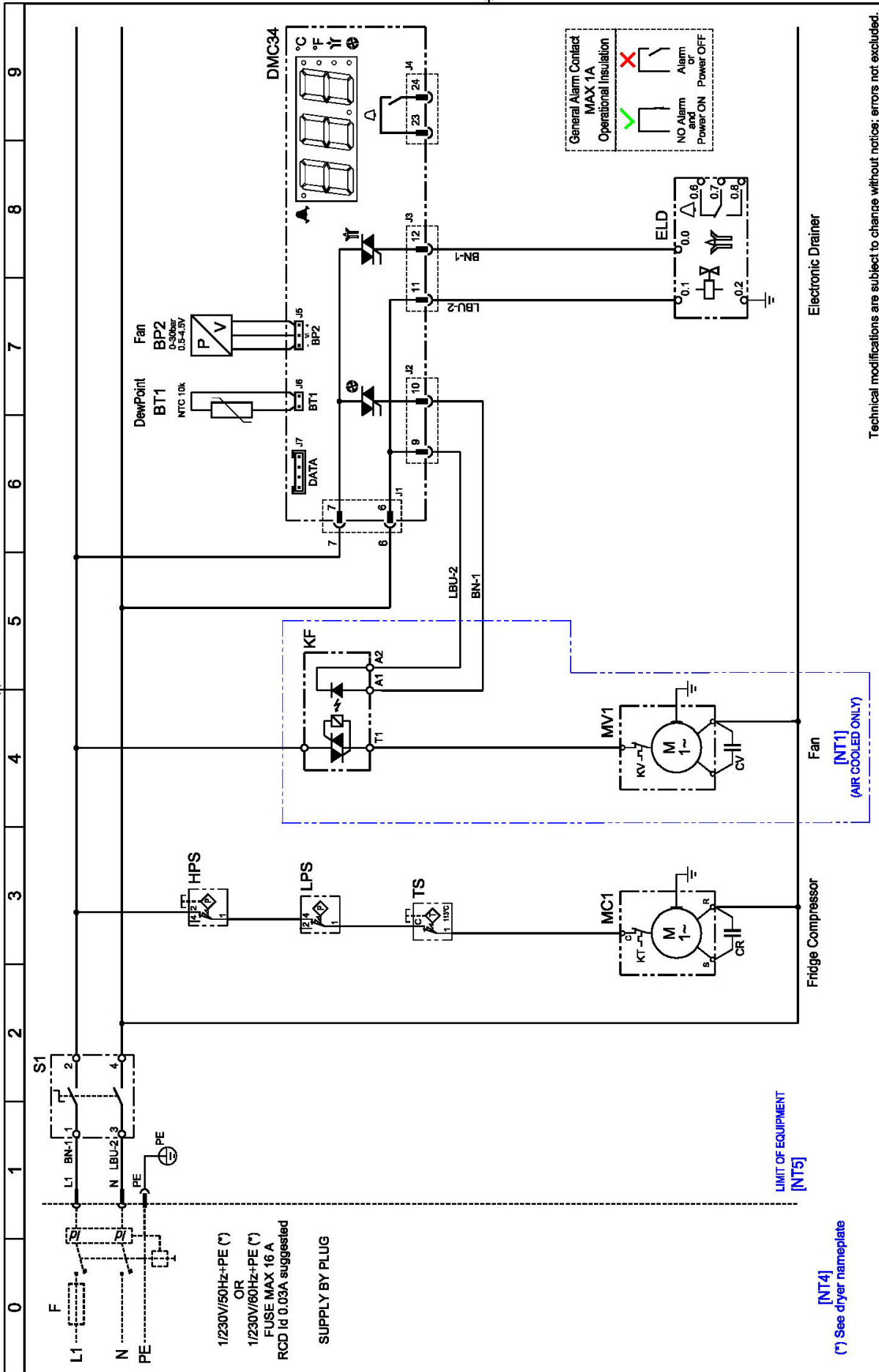

Technical modifications are subject to change without notices; errors not excluded.

Rev.

Drawing no. :

WD020\_V02

00

Note :

Sheet 01 of 01

**13.3.8 Electric diagram DRYPOINT RS 320-1010 HP50 3phase Sheet 1/3**

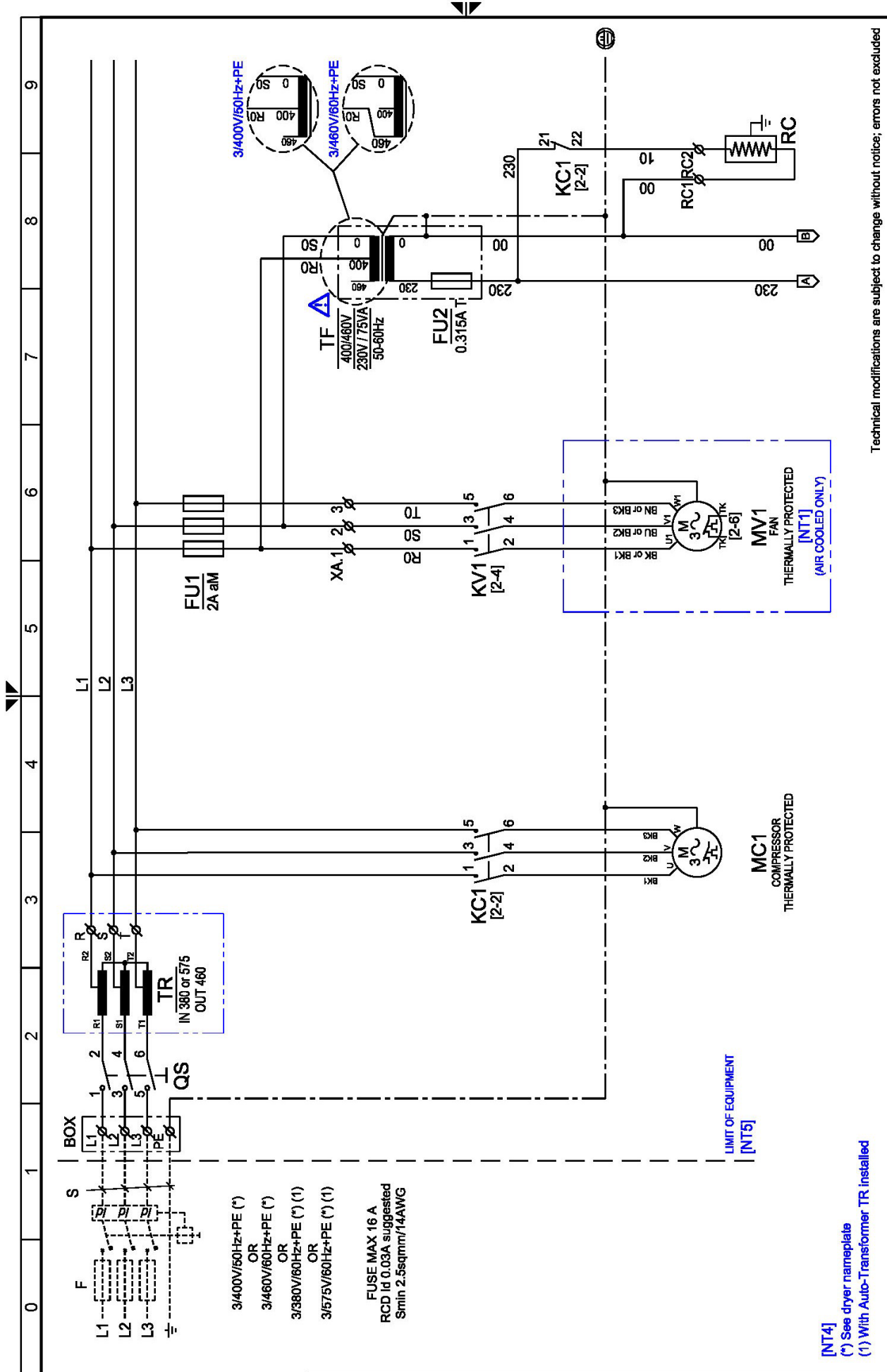

Technical modifications are subject to change without notice; errors not excluded

Rev. WD5478QCCD061\_V07 02  
Drawing no.:  
Note:

**13.3.9 Electric diagram DRYPOINT RS 320-1010 HP50 3phase Sheet 2/3**

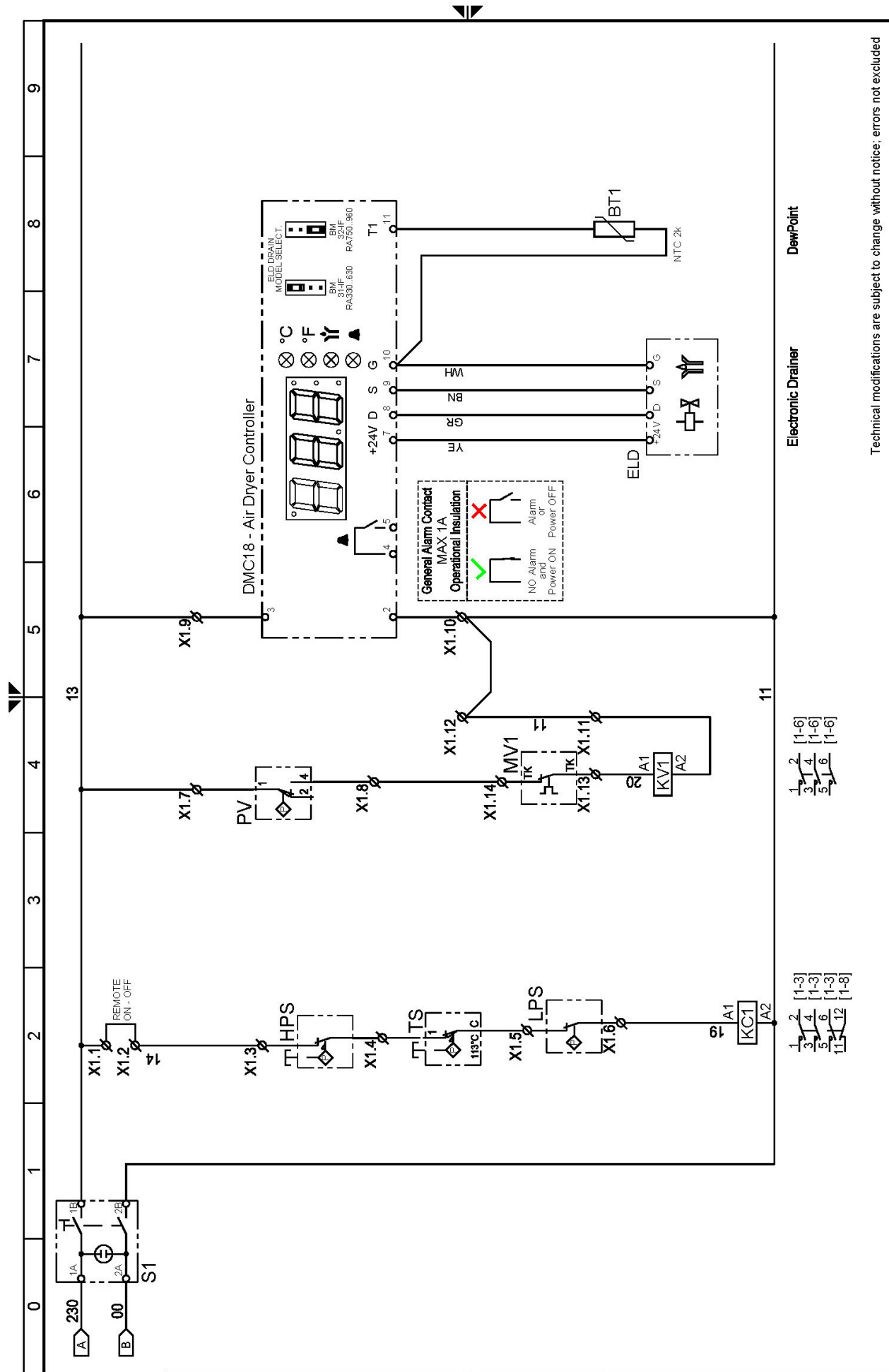

Technical modifications are subject to change without notice; errors not excluded

Drawing no. :  
WD5478QCD061\_V07  
Rev. 02  
Note :  
Sheet 02 of 03

**13.3.10 Electric diagram DRYPOINT RS 320-1010 HP50 3phase Sheet 3/3**

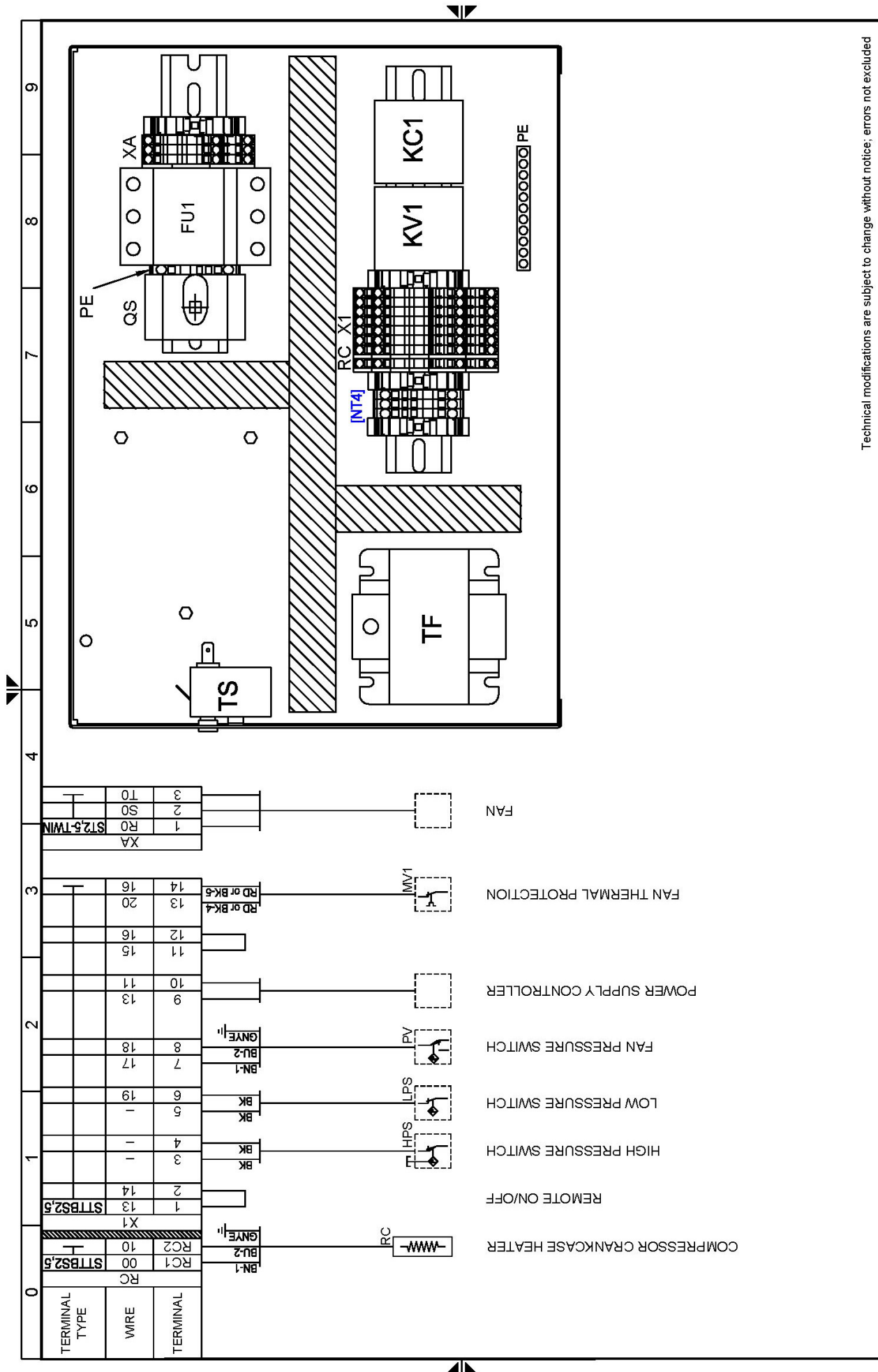

Technical modifications are subject to change without notice; errors not excluded

Drawing no.: WVD5478QC.D061\_V07  
 Rev.: 02  
 Note: -

Sheet 03 of 03



## 14 EC Declaration of conformity

BEKO TECHNOLOGIES GMBH  
Im Taubental 7  
41468 Neuss

GERMANY

Tel: +49 2131 988-0  
www.beko-technologies.com



### EU-Konformitätserklärung

Wir erklären hiermit, dass die nachfolgend bezeichneten Produkte den Anforderungen der einschlägigen Richtlinien und technischen Normen entsprechen. Diese Erklärung bezieht sich nur auf die Produkte in dem Zustand, in dem sie von uns in Verkehr gebracht wurden. Nicht vom Hersteller angebrachte Teile und/oder nachträglich vorgenommene Eingriffe bleiben unberücksichtigt.

Produktbezeichnung: DRYPOINT® RS  
Modelle: 25 HP 50, 45 HP 50, 70 HP 50, 90 HP 50, 135 HP 50,  
180 HP 50, 240 HP 50, 320 HP 50, 450 HP 50, 620 HP 50,  
810 HP 50  
Spannungsvarianten: 230 VAC  
Max. Betriebsdruck: 50 bar (g)  
Produktbeschreibung und Funktion: Kältetrockner zur Herabsetzung des Drucktaupunkts in  
Druckluft

#### Maschinen-Richtlinie 2006/42/EG

Angewandte harmonisierte Normen: EN 14119, EN 14120, EN 12100, EN 13849-1; EN 60204-1  
Name des Dokumentationsbevollmächtigten: Herbert Schlensker, Im Taubental 7, 41468 Neuss,  
Deutschland

#### Druckgeräte-Richtlinie 2014/68/EG

Angewandte harmonisierte Normen: ASME VIII Div. 1, EN 378-2, EN 10028-3, EN 12451  
Angewandtes  
Konformitätsbewertungsverfahren: Modul A

Die Produkte 25 HP 50 – 240 HP 50 fallen in keine Druckgerätekategorie und sind gemäß Artikel 4 Absatz 3 in Übereinstimmung mit der in den Mitgliedstaaten geltenden guten Ingenieurspraxis ausgelegt und werden dieser entsprechend hergestellt.

#### Niederspannungs-Richtlinie 2014/35/EU

Angewandte harmonisierte Normen: EN 60204-1

#### EMV-Richtlinie 2014/30/EU

Angewandte harmonisierte Normen: EN 61000-6-2:2005, EN 61000-6-4:2007+A1:2011

#### ROHS II-Richtlinie 2011/65/EU

Die Vorschriften der Richtlinie 2011/65/EU zur Beschränkung der Verwendung bestimmter gefährlicher Stoffe in Elektro- und Elektronikgeräten werden erfüllt.

Der Hersteller trägt die alleinige Verantwortung für die Ausstellung dieser Konformitätserklärung.

Unterzeichnet für und im Namen von:

Neuss, 22.07.2016

BEKO TECHNOLOGIES GMBH

  
i.V. Christian Riedel

Leiter Qualitätsmanagement International

**BEKO TECHNOLOGIES GMBH**  
Im Taubental 7  
41468 Neuss

GERMANY

Tel: +49 2131 988-0  
www.beko-technologies.com



## EU-Konformitätserklärung

Wir erklären hiermit, dass die nachfolgend bezeichneten Produkte den Anforderungen der einschlägigen Richtlinien und technischen Normen entsprechen. Diese Erklärung bezieht sich nur auf die Produkte in dem Zustand, in dem sie von uns in Verkehr gebracht wurden. Nicht vom Hersteller angebrachte Teile und/oder nachträglich vorgenommene Eingriffe bleiben unberücksichtigt.

Produktbezeichnung:	DRYPOINT® RS
Modelle:	1010 HP 50, 1300 HP 45, 1600 HP 45, 2300 HP 45, 2400 HP 45, 3000 HP 45, 4000 HP 45
Spannungsvarianten:	230 VAC (nur 1010 HP 50) 400 VAC (nur 1300 HP 45 – 4000 HP 45)
Max. Betriebsdruck:	50 bar (nur 1010 HP 50) 45 bar (nur 1300 HP 45 – 4000 HP 45)
Produktbeschreibung und Funktion:	Kältetrockner zur Herabsetzung des Drucktaupunkts in Druckluft

### Maschinen-Richtlinie 2006/42/EG

Angewandte harmonisierte Normen:	EN 14119, EN 14120, EN 12100, EN 13849-1; EN 60204-1
Name des Dokumentationsbevollmächtigten:	Herbert Schlensker, Im Taubental 7, 41468 Neuss, Deutschland

### Druckgeräte-Richtlinie 2014/68/EG

Angewandte harmonisierte Normen:	ASME VIII Div. 1, EN 378-2, EN 10028-3, EN 12451
Angewandtes Konformitätsbewertungsverfahren:	Modul A2
Benannte Stelle:	British Engineering Services, London, UK

### Niederspannungs-Richtlinie 2014/35/EU

Angewandte harmonisierte Normen:	EN 60204-1
----------------------------------	------------

### EMV-Richtlinie 2014/30/EU

Angewandte harmonisierte Normen:	EN 61000-6-2:2005, EN 61000-6-4:2007+A1:2011
----------------------------------	--

### ROHS II-Richtlinie 2011/65/EU

Die Vorschriften der Richtlinie 2011/65/EU zur Beschränkung der Verwendung bestimmter gefährlicher Stoffe in Elektro- und Elektronikgeräten werden erfüllt.

Die Produkte sind mit dem abgebildeten Zeichen gekennzeichnet:



Der Hersteller trägt die alleinige Verantwortung für die Ausstellung dieser Konformitätserklärung.

Unterzeichnet für und im Namen von:

Neuss, 22.07.2016

**BEKO TECHNOLOGIES GMBH**



i.V. Christian Riedel

Leiter Qualitätsmanagement International



<p><b>Headquarter :</b></p> <p><b>Deutschland / Germany</b>  BEKO TECHNOLOGIES GMBH  Im Taubental 7  D-41468 Neuss  Tel. +49 2131 988 0  info@beko-technologies.de</p>	<p>中华人民共和国 / China  BEKO TECHNOLOGIES (Shanghai)  Co. Ltd.  Rm. 606 Tomson Commercial Building  710 Dongfang Rd.  Pudong Shanghai China  P.C. 200122  Tel. +86 21 508 158 85  info@beko-technologies.cn</p>	<p><b>France</b>  BEKO TECHNOLOGIES S.a.r.l.  Zone Industrielle  1 rue des Frères Rémy  F- 57200 Sarreguemines  Tel. +33 387 283 800  Info@beko-technologies.fr</p>
<p><b>India</b>  BEKO COMPRESSED AIR  TECHNOLOGIES Pvt. Ltd.  Plot No.43/1, CIEEP, Gandhi Nagar,  Balanagar, Hyderabad  500 037, INDIA  Tel. +91 40 23080275  eric.purushotham@bekoindia.com</p>	<p><b>Italia / Italy</b>  BEKO TECHNOLOGIES S.r.l  Via Peano 86/88  I - 10040 Leini (TO)  Tel. +39 011 4500 576  info.it@beko-technologies.com</p>	<p>日本 / Japan  BEKO TECHNOLOGIES K.K  KEIHIN THINK 8 Floor  1-1 Minamiatarida-machi  Kawasaki-ku, Kawasaki-shi  JP-210-0855  Tel. +81 44 328 76 01  info@beko-technologies.jp</p>
<p><b>Benelux</b>  BEKO TECHNOLOGIES B.V.  Veenen 12  NL - 4703 RB Roosendaal  Tel. +31 165 320 300  benelux@beko-technologies.com</p>	<p><b>Polska / Poland</b>  BEKO TECHNOLOGIES Sp. z o.o.  ul. Chłapowskiego 47  PL-02-787 Warszawa  Tel. +48 22 855 30 95  info.pl@beko-technologies.pl</p>	<p><b>Scandinavia</b>  www.beko-technologies.de</p>
<p><b>España / Spain</b>  BEKO Tecnológica España S.L.  Torruella i Urpina 37-42, nave 6  E-08758 Cervelló  Tel. +34 93 632 76 68  info.es@beko-technologies.es</p>	<p><b>South East Asia</b>  BEKO TECHNOLOGIES S.E.Asia  (Thailand) Ltd.  75/323 Romklao Road  Sansab, Minburi  Bangkok 10510 - Thailand  Tel. +66 2-918-2477  info.th@beko-technologies.com</p>	<p>臺灣 / Taiwan  BEKO TECHNOLOGIES Co.,Ltd  16F.-5, No.79, Sec. 1,  Xintai 5th Rd., Xizhi Dist.,  New Taipei City 221,  Taiwan (R.O.C.)  Tel. +886 2 8698 3998  info@beko.com.tw</p>
<p><b>Česká Republika / Czech Republic</b>  BEKO TECHNOLOGIES s.r.o.  Mlýnská 1392  CZ - 562 01 Usti nad Orlici  Tel. +420 465 52 12 51  info.cz@beko-technologies.cz</p>	<p><b>United Kingdom</b>  BEKO TECHNOLOGIES LTD.  2 West Court  Buntsford Park Road  Bromsgrove  GB-Worcestershire B60 3DX  Tel. +44 1527 575 778  info@beko-technologies.co.uk</p>	<p><b>USA</b>  BEKO TECHNOLOGIES CORP.  900 Great SW Parkway  US - Atlanta, GA 30336  Tel. +1 404 924-6900  beko@bekousa.com</p>

