

EN - english

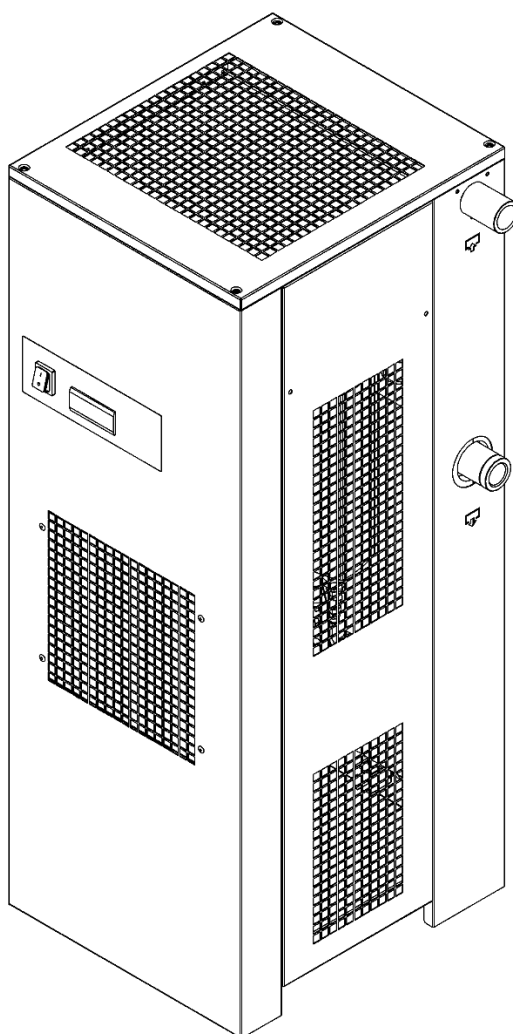

Instructions for installation and operation

Compressed air refrigeration dryer **DRYPOINT® RA HT 5-100**



Dear customer,

Thank you for deciding in favour of the DRYPOINT® RA HT 5-100 compressed-air refrigeration dryer. Please read these installation and operating instructions carefully before mounting and starting up the DRYPOINT® RA HT 5-100 and follow our directions. Perfect functioning of the DRYPOINT® RA HT 5-100 and thus reliable compressed-air drying can only be guaranteed when the provisions and notes stipulated here are strictly adhered to.

Contents

1	Type plate	5
2	Safety instructions	5
2.1	Safety pictograms in accordance with DIN 4844	6
2.3	Signal words in accordance with ANSI	8
2.4	Overview of the safety instructions	8
3	Proper use	11
4	Exclusion from a field of application	11
5	Operating instructions in accordance with the 2014/68/EU Pressure Equipment Directive	12
6	Transport	12
7	Storage	12
8	Installation	13
8.1	Place of installation	13
8.2	Installation plan	14
8.3	Correction factors	15
8.4	Connection to the compressed-air system	16
8.5	Electrical connections	17
8.6	Condensate drain	17
9	Start-up	18
9.1	Preliminary stages	18
9.2	Initial start-up	18
9.3	Start-up and shut down	19
10	Technical data	20
11	Technical description	21
11.1	Control panel	21
11.2	Functional description	21
11.3	Flow chart	22
11.4	Refrigerating compressor	23
11.5	Condenser	23
11.6	Aftercooler	23
11.7	Pre-Filter (1 micron)	23
11.8	Filter dryer	23
11.9	Capillary tube	23
11.10	Aluminium heat exchanger	23
11.11	Hot-gas bypass valve	23
11.12	Refrigerant pressure switches LPS – HPS	24
11.13	Safety thermo switch TS	24
11.15	Electronic controller DMC34	25
11.15.1	How to switch on the dryer	25
11.15.2	How to switch off the dryer	25
11.15.3	How to display the operating parameters	25
11.15.4	How a service warning / alarm is displayed	25
11.15.5	How is controlled the condenser fan	26
11.15.6	How is controlled the drain solenoid valve	26
11.15.7	How to reset the service reminder timer	26
11.15.8	Operation of the failure / alarm dry contact	26
11.15.9	How to change the operating parameters	26
11.16	Electronically level-controlled BEKOMAT condensate drain	27
12	Maintenance, troubleshooting, spare parts and dismantling	28
12.1	Checks and maintenance	28
12.2	Troubleshooting	29
12.3	Recommended spare parts	33
12.4	Maintenance works at the refrigeration cycle	34
12.5	Dismantling the dryer	34
13	Appendices	35
13.1	Dryer dimensions	35
13.1.1	Dryer dimensions DRYPOINT RA HT 5-12	35

13.1.2	Dryer dimensions DRYPOINT RA HT 18-23	36
13.1.3	Dryer dimensions DRYPOINT RA HT 30-40	37
13.1.4	Dryer dimensions DRYPOINT RA HT 55-60	38
13.1.5	Dryer dimensions DRYPOINT RA HT 80-100	39
13.2	Exploded diagrams	40
13.2.1	Components of the exploded diagrams	40
13.2.2	Exploded diagram DRYPOINT RA HT 5-18	41
13.2.3	Exploded diagram DRYPOINT RA HT 23	42
13.2.4	Exploded diagram DRYPOINT RA HT 30	43
13.2.5	Exploded diagram DRYPOINT RA HT 40-55	44
13.2.6	Exploded diagram DRYPOINT RA HT 80-100	45
13.3	Electric diagrams	46
13.3.1	Electric diagrams – list of components	46
13.3.2	Electric diagram DRYPOINT RA HT 5-12	47
13.3.3	Electric diagram DRYPOINT RA HT 18-23	48
13.3.4	Electric diagram DRYPOINT RA HT 30	49
13.3.5	Electric diagram DRYPOINT RA HT 40	50
13.3.6	Electric diagram DRYPOINT RA HT 55-60	51
13.3.7	Electric diagram DRYPOINT RA HT 80-100	52
14	Declaration of conformity	53

1 Type plate

The type plate is on the back of the dryer and comprises all primary data of the device. Always refer to these when contacting the manufacturer or the sales department.

All guarantee claims will expire in the event that the type plate is modified or removed.

The dryer model printed on the typeplate includes one or more suffixes that specify one or more features of dryer.

Explanation of 1st suffix for power supply requirements :

1st SUFFIX	DESCRIPTION OF FEATURE
none	1/230/50
-C	3/400/50
-P	1/115/60
-E	1/230/60
-R	3/460/60
-S	3/230/60 (with internal autotransformer)
-F	3/380/60 (with internal autotransformer)
-T	3/690/60 (with internal autotransformer)

Explanation of 2nd suffix for cooling requirements :

2nd SUFFIX	DESCRIPTION OF FEATURE
/ AC	Air cooled

Explanation of (eventual) 3rd suffix for special features :

3rd SUFFIX	DESCRIPTION OF FEATURE
-TAC	Anti corrosion treatment
-SP	Special feature
-OF	Dryer oil free

Example : DP RA HT 100-E /AC eco → DRYPOINT RA HT 100, 1/230/60, Air cooled

2 Safety instructions



Please check whether or not these instructions correspond to the device type.

Please adhere to all advice given in these operating instructions. They include essential information which must be observed during installation, operation and maintenance. Therefore, it must be ensured that these operating instructions are read by the fitter and the responsible operator / certified skilled personnel prior to installation, start-up and maintenance.

The operating instructions must be accessible at all times at the place of application of the DRYPOINT® RA HT 5-100 compressed-air refrigeration dryer.

In addition to these operating instructions, local and national regulations need to be observed, where required .

Ensure that operation of the DRYPOINT® RA HT 5-100 compressed-air refrigeration dryer only takes place within the permissible limit values indicated on the type plate. Any deviation from these limit values involves a risk for persons and for the material, and may result in malfunction or a breakdown.

After installing the device correctly and in accordance with the instructions in this manual, the dryer is ready to operate, further settings are not required. Operation is fully automatic and maintenance is limited to several examinations and cleaning measures which are described in the following chapters.

This manual must be available at all times for future reference and is a constituent part of the dryer.

If you have any queries regarding these installation and operating instructions, please contact BEKO TECHNOLOGIES GMBH.

Safety instructions

2.1 Safety pictograms in accordance with DIN 4844



Observe operating instructions



General danger symbol



Supply voltage



Danger: component or system under pressure



Hot surfaces



Non-breathable air



Do not use water to extinguish the fire



Do not operate with open cover (housing)



Maintenance works or controlling measures must only be carried out by qualified personnel¹



Do not smoke



Note



Connection point compressed-air inlet



Connection point compressed-air outlet



Connection point condensate drain

¹ Certified skilled personnel are persons who are authorised by the manufacturer, with experience and technical training, who are well-grounded in the respective provisions and laws and capable of carrying out the required works and of identifying and avoiding any risks during the machine transport, installation, operation and maintenance. Qualified and authorised operators are persons who are instructed by the manufacturer regarding the handling of the refrigeration system, with experience and technical training, and who are well-grounded in the respective provisions and laws.



Works can be carried out by the operator of the plant, provided that they are skilled accordingly¹.

NOTE: Text that contains important specifications to be considered – does not refer to safety precautions.



The device was carefully designed with particular attention paid to environmental protection:

- CFC-free refrigerants
- CFC-free insulation material
- Energy-saving design
- Limited acoustic emissions
- Dryer and packaging comprise reusable materials

This symbol advises the user to observe the environmental aspects and comply with the recommendations connected with this symbol.

2.3 Signal words in accordance with ANSI

Danger!	Imminent hazard Consequences of non-observance: serious injury or death
Warning!	Potential hazard Consequences of non-observance: possible serious injury or death
Caution!	Imminent hazard Consequences of non-observance: possible injury or property damage
Notice!	Potential hazard Consequences of non-observance: possible injury or property damage
Important!	Additional advice, info, hints Consequences of non-observance: disadvantages during operation and maintenance, no danger

2.4 Overview of the safety instructions



Certified skilled personnel

Installation works must exclusively be carried out by authorised and qualified skilled personnel. Prior to undertaking any measures on the DRYPOINT® RA HT 5-100 compressed-air refrigeration dryer, the certified skilled personnel shall read up on the device by carefully studying the operating instructions. The operator is responsible for the adherence to these provisions. The respective directives in force apply to the qualification and expertise of the certified skilled personnel.

For safe operation, the device must only be installed and operated in accordance with the indications in the operating instructions. In addition, the national and operational statutory provisions and safety regulations, as well as the accident prevention regulations required for the respective case of application, need to be observed during employment. This applies accordingly when accessories are used.



Danger!

Compressed air!

Risk of serious injury or death through contact with quickly or suddenly escaping compressed air or through bursting and/or unsecured plant components.

Compressed air is a highly dangerous energy source.

Never work on the dryer when the system is under pressure.

Never direct the compressed-air outlet or condensate drain hoses at persons.

The user is responsible for the proper installation of the dryer. Non-observance of the instructions in the "Installation" chapter leads to the expiration of the guarantee. Improper installation may result in dangerous situations for the personnel and/or the device.



Danger!

Supply voltage!

Contact with non-insulated parts carrying supply voltage involves the risk of an electric shock resulting in injuries and death.

Only qualified and skilled personnel are authorised to run electrically-operated devices. Prior to undertaking maintenance measures at the device, the following requirements must be met:

Make sure that the power supply is switched off and that the device is off and marked for maintenance measures. Please also ensure that the power supply cannot be re-established during the works.



Caution!

Refrigerant!

The compressed-air refrigeration dryer uses HFC-containing refrigerants as a coolant.

Please observe the corresponding paragraph entitled "Maintenance works at the refrigeration cycle".

**Warning!****Refrigerant leak!**

A refrigerant leak involves the danger of serious injury and damage to the environment.



The DRYPOINT® RA HT 5-100 compressed-air refrigeration dryer contains fluorinated greenhouse gas/refrigerant.



Installation, repair and maintenance works at the refrigeration system must only be carried out by certified skilled personnel (specialists). A certification in accordance with EC regulation 303/2008 must be available.



The requirements of the EC 842/2006 directive must be met under all circumstances.

Please refer to the indications on the type plate as regards the type and amount of refrigerant.



Comply with the following protective measures and rules of conduct:

1. **Storage:** Keep the container tightly closed. Keep it in a cool and dry place. Protect it against heat and direct sunlight. Keep it away from ignition sources.
2. **Handling:** Take measures against electrostatic charging. Ensure good ventilation/suction at the workplace. Check fittings, connections and ducts for tightness. Do not inhale the gas. Avoid contact with the eyes or the skin.
3. Prior to carrying out works on refrigerant-carrying parts, remove the refrigerant to such an extent that safe working is possible.
4. Do not eat, drink or smoke during work. Keep out of the reach of children.
5. **Breathing protection:** ambient-air-independent respirator (at high concentrations).
6. **Eye protection:** sealing goggles.
7. **Hand protection:** protective gloves (e.g. made of leather).
8. **Personal protection:** protective clothing.
9. **Skin protection:** use protective cream.

In addition, the safety data sheet for the refrigerant needs to be observed!

**Caution!****Hot surfaces!**

During operation, several components can reach surface temperatures of more than +60°C. There is the risk of burns.

All components concerned are installed inside of the closed housing. The housing must only be opened by certified skilled personnel².

**Caution!****Improper use!**

The device is intended for the separation of water in compressed air. The dried air cannot be used for breathing-air purposes and is not suitable for the direct contact with food.

This dryer is not suitable for the treatment of contaminated air or of air containing solids.

**Note!****Contaminated intake air!**

In the event that the intake air is strongly contaminated (ISO 8573.1 class 3.-3 or poorer quality), we recommend the additional installation of a prefilter (e.g. CLEARPOINT F040), to avoid clogging of the heat exchanger.

² Certified skilled personnel are persons who are authorised by the manufacturer, with experience and technical training, who are well-grounded in the respective provisions and laws and capable of carrying out the required works and of identifying and avoiding any risks during the machine transport, installation, operation and maintenance. Qualified and authorised operators are persons who are instructed by the manufacturer regarding the handling of the refrigeration system, with experience and technical training, and who are well-grounded in the respective provisions and laws.



Caution!

Heating-up through fire!

In the event of a heating-up through fire, the containers and pipes of the refrigerant system can burst.



In this case, please proceed as follows:

Switch off the refrigeration plant.

Switch off the mechanical ventilation of the machinery compartment.

Use ambient-air-independent respirators.

Containers and plants which are filled with refrigerant can burst violently in the event of fire.

The refrigerants themselves are incombustible, but they are degraded to very toxic products at high temperatures.

Remove the container/plant from the fire zone, as there is the risk of bursting!

Cool down containers and bottles via a directed water jet from a safe position.

In the event of fire, please use an approved fire extinguisher. Water is not a suitable agent to extinguish an electrical fire.

This must only be carried out by persons who are trained and informed about the hazards emanating from the product.



Caution!

Unauthorised intervention!

Unauthorised interventions may endanger persons and plants and lead to malfunction.

Unauthorised interventions, modification and abuse of the pressure devices are prohibited.

The removal of sealings and leadings at safety devices is prohibited.

Operators of the devices must observe the local and national pressure equipment regulations in the country of installation.



Note!

Ambient conditions!

In the event that the dryer is not installed under suitable ambient conditions, the ability of the device to condense refrigerant gas is impaired. This can result in a higher load of the refrigerating compressor, and in a loss of efficiency and performance of the dryer.

This in turn leads to overheated condenser fan motors, to malfunction of electric components and to a breakdown of the dryer. Failures of this type will affect warranty considerations.

Do not install the dryer in an environment in which chemicals with a corrosive effect, explosive gases, toxic gases, evaporation heat, high ambient temperatures or extreme dust and dirt can be found.

3 Proper use

This dryer was designed, manufactured and tested to separate the moisture which normally exists in compressed air. Any other use is considered improper.

The manufacturer shall not be liable for problems occurring as a consequence of improper use. The user alone is responsible for any damage resulting from that.

Furthermore, the correct use includes the compliance with the installation instructions, in particular in respect of:

- The voltage and frequency of the main voltage supply.
- The pressure, temperature and flow rate of the inlet air.
- The ambient temperature.

When delivered, the dryer is tested and fully assembled. The customer only needs to connect the device to the system in accordance with the instructions in the following chapters.

4 Exclusion from a field of application



Note!
Improper use!



The device is intended for the separation of water in compressed air. The dried air cannot be used for breathing-air purposes and is not suitable for the direct contact with food.

This dryer is not suitable for the treatment of contaminated air or of air containing solids.

5 Operating instructions in accordance with the 2014/68/EU Pressure Equipment Directive

The DRYPOINT® RA HT 5-100 compressed-air refrigeration dryer contains pressure equipment in the sense of the 2014/68/EU Pressure Equipment Directive. Therefore, the entire plant needs to be registered with the supervisory authority if required in accordance with the local regulations.

For the examination prior to the start-up and for periodic inspections, the national regulations need to be observed, such as the industrial safety regulation in the Federal Republic of Germany. In countries outside the EU, the respective regulations in force there need to be adhered to.

The proper use of pressure devices is the basic requirement for safe operation. As regards pressure devices, the following points need to be observed:

- The DRYPOINT® RA HT 5-100 compressed-air refrigeration dryer must only be employed within the pressure and temperature range limits indicated by the manufacturer on the type plate.
- No welding must be carried out on the pressure parts.
- The DRYPOINT® RA HT 5-100 compressed-air refrigeration dryer must neither be installed in insufficiently ventilated rooms nor near heat sources or inflammable substances.
- To avoid fractures resulting from material fatigue, the refrigeration dryer should not be exposed to vibrations during operation.
- The maximum operating pressure indicated by the manufacturer on the type plate must not be exceeded. It is the installer's responsibility to install the appropriate safety and control devices. Prior to the start-up of the DRYPOINT® RA HT 5-100 compressed-air refrigeration dryer, the connected pressure generator (compressor etc.) must be set to the max. permissible operating pressure. The integrated safeguard needs to be checked by an approved inspection agency.
- The documents related to the DRYPOINT® RA HT 5-100 compressed-air refrigeration dryer (manual, operating instructions, manufacturer's declaration etc.) must be kept safe for future reference.
- No objects whatsoever must be installed at or placed on the DRYPOINT® RA HT 5-100 compressed-air refrigeration dryer and the connecting lines.
- Installation of the plant in frost-free places only.
- Operation of the plant is only permissible with fully closed and intact housing and cover panels. Operation of the plant with damaged housing/cover panels is prohibited.

6 Transport

Check the packaging for visible loss or damage. If no visible damage can be ascertained, place the unit in close proximity to the place of installation and unpack the device.

During this procedure, the dryer must always remain in an upright position. The components may be damaged when the unit is tilted or turned upside down.

Store the device in a dry environment and do not expose it to extreme weather conditions.

Handle with care. Strong shocks can cause irreparable damage.

7 Storage

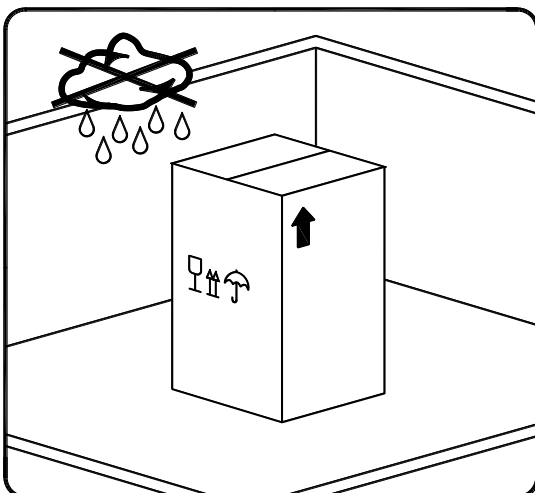

Keep the device away from extreme weather conditions even when packaged.

Keep the dryer in an upright position, also while it is stored. Tilting the device or turning it upside down can cause irreparable damage to some components.

When the dryer is not in use, it can be stored in its packaging in a dust-free and protected place at a temperature of +1°C ... +50°C and at a specific humidity of max. 90%. If the storage period exceeds 12 months, you should contact the manufacturer.



The packaging material is recyclable. Dispose of the material in accordance with the directives and provisions in force in the country of destination

8 Installation

8.1 Place of installation

**Note!****Ambient conditions!**

In the event that the dryer is not installed under suitable ambient conditions, the ability of the device to condense refrigerant gas is impaired. This can result in a higher load of the refrigerating compressor, and in a loss of efficiency and performance of the dryer.

This in turn leads to overheated condenser fan motors, to malfunction of electric components and to a breakdown of the dryer. Failures of this type will affect warranty considerations.

Do not install the dryer in an environment in which chemicals with a corrosive effect, explosive gases, toxic gases, evaporation heat, high ambient temperatures or extreme dust and dirt can be found.

Minimum installation requirements:

- Choose an area which is clean and dry, free from dust and protected against atmospheric disturbances.
- The load-bearing zone must be even, horizontal and able to bear the weight of the dryer.
- Minimum ambient temperature +1°C.
- Maximum ambient temperature +50°C.
- Ensure a proper cooling air replacement.
- Allow a sufficient clearance on each side of the dryer for proper ventilation and to facilitate maintenance operations. The dryer does not require attachment to the floor surface.

**Do not obstruct the ventilation grille.**

Prevent any recirculation of the outgoing cooling air.

Protect the dryer against draughts.

**Note!**

Dryers models RA HT 5-12 can be wall-mounted. See fixing dimensions on dimensional drawings in the appendices section.

The hanging mounting inevitably causes the obstruction of the ventilation grid positioned on the panel facing the wall fixing. This obstruction, in any case, does not prejudice the efficiency of the ventilation inside the dryer which is guaranteed by other grids on the other panels.

8.2 Installation plan

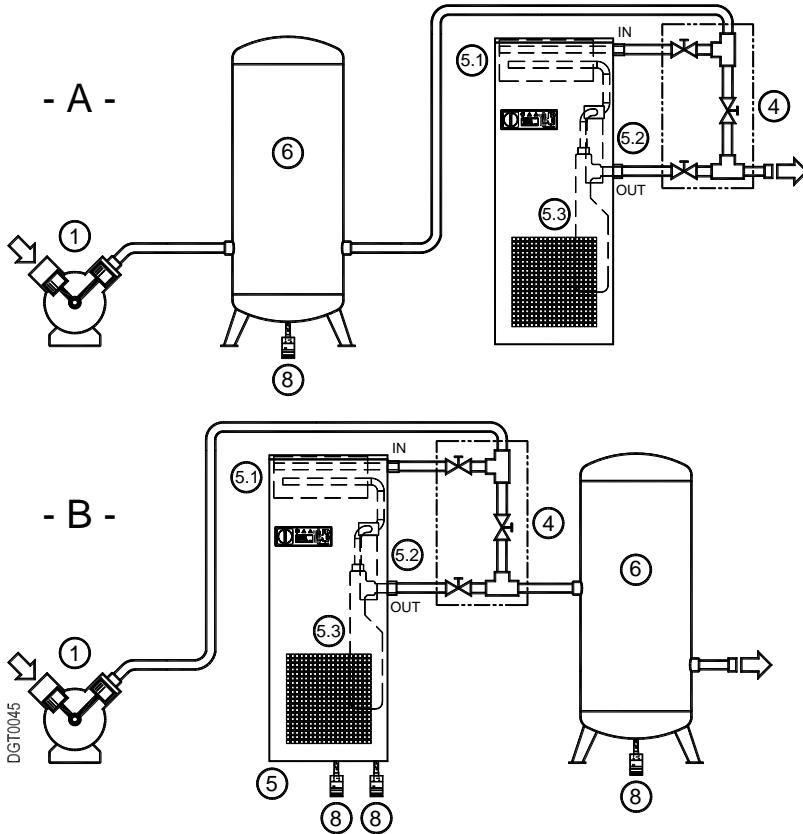

- 1 Air compressor
- 4 By-pass group
- 5 Dryer
- 5.1 Aftercooler
- 5.2 Pre-Filter
- 5.3 Alu-Dry Module
- 6 Compressed-air tank
- 8 Bekomat condensate drain

Installation **type A** is recommended when the total consumption corresponds to the throughput rate of the compressor. Installation **type B** is recommended when the air consumption constantly varies, with peak values which considerably exceed the throughput rate of the compressor. The storage capacity of the tank must be dimensioned in such a way that a possible short-term high air demand (peak air consumption) can be compensated.



Do not obstruct the ventilation grille.
Prevent any recirculation of the outgoing cooling air.
Protect the dryer against draughts.



Note!
Contaminated intake air!
In the event that the intake air is strongly contaminated (ISO 8573.1 class 3.-3 or poorer quality), we recommend the additional installation of a prefilter (e.g. CLEARPOINT F040), to avoid clogging of the heat exchanger.

8.4 Connection to the compressed-air system



Danger! **Compressed air!**

All works must only be carried out by qualified skilled personnel.

Never work on compressed-air systems which are under pressure.



The operator or the user must ensure that the dryer is never operated with a pressure exceeding the maximum pressure value indicated on the type plate.

Exceeding the maximum operating pressure can be dangerous for the operator but also for the device.

The air temperature and the air flow at the inlet of the dryer must lie within the limit values indicated on the type plate. The connecting lines must be free from dust, iron rust, shards and other contaminations and correspond to the flow rate of the dryer. Should air with a very high temperature be treated, the installation of an aftercooler may be necessary. For the implementation of maintenance works, the installation of a bypass system is recommended.

The dryer was designed in such a manner that vibrations that may occur during operation are limited. Therefore, it is advisable to employ connecting lines (flexible hoses, vibration-inhibiting fittings etc.) which protect the dryer against possible vibrations in the pipework.

Note!



Contaminated intake air!

In the event that the intake air is strongly contaminated (ISO 8573.1 class 3.-3) or poorer quality, we recommend the additional installation of a prefilter (e.g. CLEARPOINT F040), to avoid clogging of the heat exchanger.

CAUTION!



During the piping of the dryer, the inlet and outlet connections need to be supported as is shown in the illustration.

Non-observance will cause damage.

8.5 Electrical connections



Danger! **Supply voltage!**

The connection to the electric mains should only be carried out by qualified skilled personnel and must correspond to the legal provisions in force in your region.

Prior to connecting the device, please check the name plate to avoid exceeding the indicated values. The voltage tolerance is +/- 10%.

DRYPOINT RA HT 5-100 dryers are supplied with a power cord and safety plug (two-pole and earth connection).

Make sure that suitable fuses or circuit breakers in accordance with the indications on the name plate are available.

A residual-current device (RCD) with $I_{\Delta n} = 0.03A$ is suggested. The cross-section of the power supply cable must correspond to the power consumption of the dryer. In this respect, the ambient temperature, the cable laying conditions, the length of the cables and the requirements of the local electricity supplier need to be considered.



Danger! **Supply voltage and missing earth connection!**

Important: ensure that the plant is connected to earth.

Do not use plug adapters at the power plug.

Possible replacement of the power plug must only be carried out by a qualified electrician.



DANGER! **Aftercooler safety thermo-switch!**

Qualified personnel should carry out the connection of the aftercooler safety thermo-switch to the air compressor.

Be sure to check that the air compressor is pressureless and not connected to the power supply.

Use the appropriate cable feedthroughs for the installation work.

8.6 Condensate drain



Danger! **Compressed air and condensate under pressure!**

The condensate is discharged at system pressure.



The drain pipe needs to be secured.

Never direct the condensate drain pipe at persons.

The dryer is delivered with an already integrated electronically level-controlled BEKOMAT condensate drain. Connect the condensate drain with a collection system or container by properly screwing it on.

Do not connect the drain with pressurised plants.



Do not discharge the condensate into the environment.

The condensate accumulating in the dryer contains oil particles which were released into the air by the compressor.

Dispose of the condensate in accordance with the local provisions.

It is advisable to install a water-oil separator, to which the total amount of condensate from the compressors, dryers, tanks, filters etc. is supplied.

We recommend ÖWAMAT oil-water separators for dispersed compressor condensate and BEKOSPLIT emulsion-splitting plants for emulsified condensate.

9 Start-up

9.1 Preliminary stages



Note!
Exceeding of the operating parameters!

Ensure that the operating parameters comply with the nominal values indicated on the name plate of the dryer (voltage, frequency, air pressure, air temperature, ambient temperature etc.).

Prior to delivery, this dryer was thoroughly tested, packed and checked. Please verify the soundness of the dryer during the initial start-up and check the perfect functioning during the first operating hours.



The initial start-up must be carried out by qualified personnel.

During the installation and operation of this device, all national regulations regarding electronics and any other federal and state ordinances, as well as local provisions, need to be adhered to.



The operator and the user must ensure that the dryer is not operated without panels.

9.2 Initial start-up



Note!

The dryer **must not be started up more than six times an hour**. Wait at least five minutes prior to every restart.

The user is responsible for the compliance with these provisions. Irreparable damage can be caused by starting up the device too often.



The method below should be applied during the first start-up, after longer downtimes or subsequent to maintenance works.

The start-up must be carried out by certified skilled personnel.

Processing sequence (see Section 11.1 "Control panel")

- Ensure that all the steps of the "Installation" chapter have been observed.
- Ensure that the connection to the compressed air system is correct and that the piping is suitably fixed and supported.
- Ensure that the condensate drain pipe is properly fastened and connected to a collection system or container.
- Ensure that the by-pass system (if installed) is closed and the dryer is isolated.
- Ensure that the manual valve of the condensate drain circuit is open.
- Remove any packaging and other material which could obstruct the area around the dryer.
- Activate the mains switch.
- Turn ON the switch - pos. 1 on the control panel.
- Ensure that electronic controller is ON.
- Ensure the consumption matches with the values of the data plate.
- Ensure the fan works properly – wait for its first interventions.
- Allow the dryer temperature to stabilise at the pre-set value.
- Slowly open the air inlet valve.
- Slowly open the air outlet valve.
- Slowly close the central by-pass valve of the system (if installed).
- Check the piping for air leakage.
- Ensure the drain is regularly cycling - wait for its first interventions.

9.3 Start-up and shut down



Start-up (refer to paragraph 11.1 Control Panel)

- Check the condenser for cleanliness.
- Turn ON the switch - pos. 1 on the control panel.
- Ensure that electronic controller is ON.
- Wait a few minutes; verify that the DewPoint temperature displayed on electronic controller is correct and that the condensate is regularly drained.
- Switch on the air compressor.



Shut down (refer to paragraph 11.1 Control Panel)

- Check that the DewPoint temperature indicated on the electronic controller is within range.
- Shut down the air compressor.
- After a few minutes, turn OFF the switch - pos. 1 on the control panel.

A DewPoint within 0°C and +10°C displayed on electronic controller is correct according to the possible working conditions (flow-rate, temperature of the incoming air, ambient temperature, etc.).

During the operation, the refrigerant compressor will run continuously. The dryer must remain on during the full usage period of the compressed air, even if the air compressor works intermittently.

During the operation, the refrigerating compressor will run continuously. The dryer must remain on during the full usage period of the compressed air, even if the air compressor works intermittently.



The number of starts must be no more than 6 per hour. The dryer must stop running for at least 5 minutes before being started up again.

The user is responsible for compliance with these rules. Frequent starts may cause irreparable damage.

10 Technical data

MODEL	DRYPOINT RA HT	5	8	12	18	23	30	40	55	60	80	100
Air flow rate at nominal condition (1)	[l/min] [m ³ /h] [scfm]	550 33 19	850 51 30	1200 72 42	1800 108 64	2300 138 81	3100 185 109	4000 240 141	5500 330 194	6200 372 219	8100 486 286	10500 630 371
Pressure DewPoint at nominal condition (1)	[°C]	7										
Nominal ambient temperature	[°C]	32										
Min...Max ambient temperature	[°C]	1...50										
Nominal inlet air temperature (max.)	[°C]	80 (100)										
Nominal inlet air pressure	[barg]	7										
Max. inlet air pressure	[barg]	16										
Air pressure drop - Δp	[bar]	0.008	0.18	0.26	0.20	0.35	0.28	0.34	0.22	0.25	0.29	0.32
Inlet - Outlet connections	[BSP-F]	G 1/2"		G 1"		G 1,1/4"		G 1,1/2"		G2"		
Refrigerant type		R134.a		R407C								
Refrigerant quantity (2)	[kg]	0.20	0.21	0.23	0.23	0.30	0.47	0.47	0.62	0.62	1.15	1.10
Cooling air fan flow	[m ³ /h]	350	350	350	650	700	830	830	2.950	3.000	5.800	5.800
Heat Rejection	[kW]	0.63	0.75	0.96	1.10	1.90	2.60	2.90	3.80	4.50	5.40	7.30
Standard Power Supply (2)	[PhV/Hz]	1/230/50										
Nominal electric consumption	[kW]	0.25	0.27	0.35	0.54	0.64	0.77	0.83	0.85	0.99	1.39	1.51
Full Load Amperage FLA	[A]	1.4	1.6	2.1	3.0	3.8	3.8	4.1	4.1	4.6	6.4	6.6
Max. noise level at 1 m	[dbA]	1.7	1.9	2.6	3.4	4.6	5.6	6.2	9.5	9.6	10.8	10.8
Weight	[kg]	30	31	33	50	51	61	66	75	84	132	138

(1) The nominal condition refers to an ambient temperature of +32°C with inlet air at 7barg and +80°C.

(2) Check the data shown on the identification plate.

11 Technical description

11.1 Control panel

The control panel explained below is the only dryer user interface.

DP RA HT 5 - 60

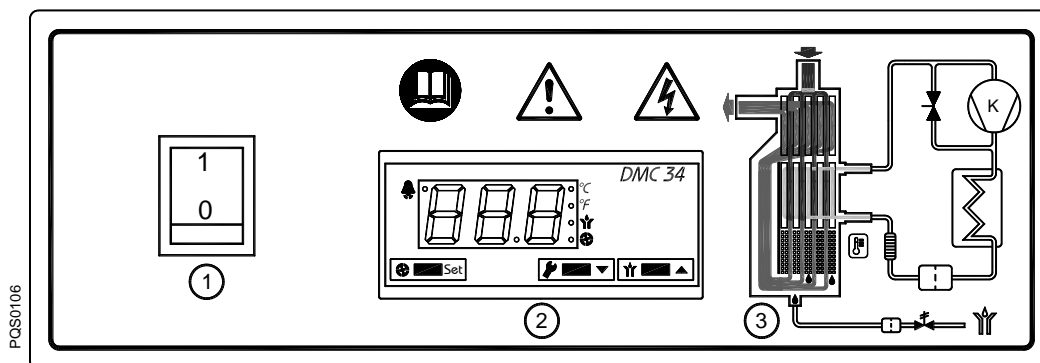

DP RA HT 80 - 100

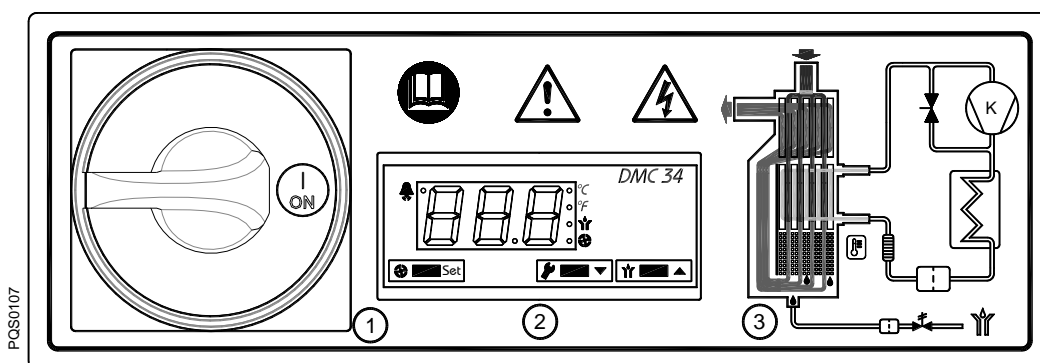

- 1 ON-OFF Switch
- 2 Electronic controller
- 3 Air and refrigerant flow diagram

11.2 Functional description

Operating principle – All dryer models described in this manual function according to the same principle. The hot and moisture-loaded air is led into an air/air heat exchanger. Afterwards, the air flows through an evaporator, which is also known as an air/refrigerant heat exchanger. The air temperature is reduced to approximately 2°C, so that water vapour condenses to liquid. The continuously accumulating condensate is collected in the separator to be discharged via the condensate drain. Subsequently, the cold and dry air is led through the air/air heat exchanger, so that it is reheated to up to 8°C below the inlet temperature when leaving the dryer.

Refrigeration cycle – Refrigerant gas is cycled through the compressor and exits at high pressure to a condenser where heat is removed causing the refrigerant to condense to a high-pressure liquid state. The liquid is forced through a capillary tube where the resulting pressure drop allows the refrigerant to boil off at a predetermined temperature. Low-pressure liquid refrigerant enters the heat exchanger where heat from the incoming air is transferred causing the refrigerant to boil; the resulting phase change produces a low pressure, low temperature gas. The low-pressure gas is returned to the compressor, where it is re-compressed and begins the cycle again. During those periods when the compressed air load is reduced the excess refrigerant is by-passed automatically back to the compressor via the Hot Gas By-pass Valve circuit.

11.3 Flow chart

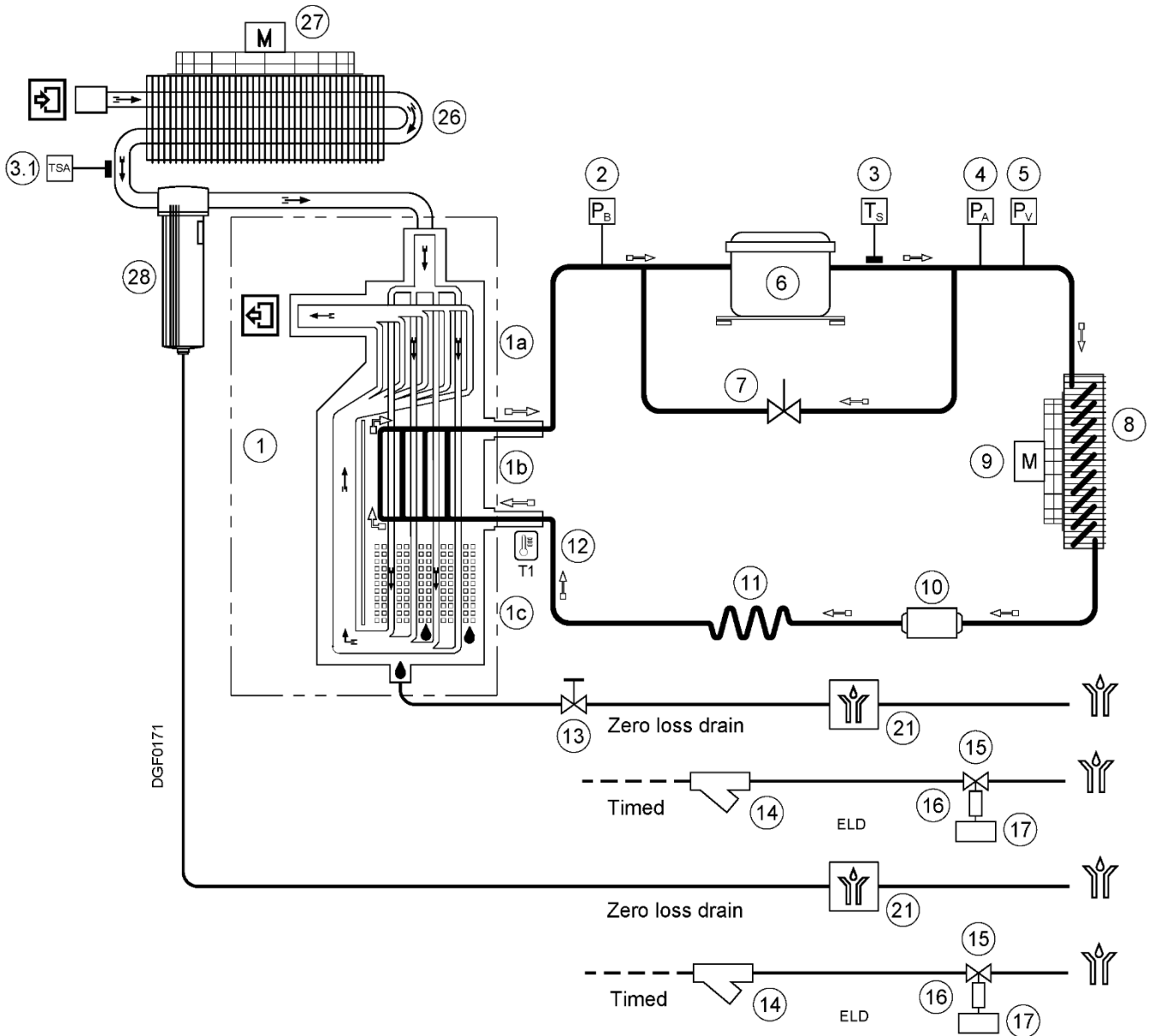

- | | |
|--|---|
| <p>1 Alu-Dry module</p> <p>1a Air-to-air heat exchanger</p> <p>1b Air-to-refrigerant heat exchanger</p> <p>1c Condensate separator</p> <p>2 Refrigerant pressure switch LPS (RA HT 80-100)</p> <p>3 Safety thermo switch TS (RA HT 30-100)</p> <p>4 Refrigerant pressure switch HPS (RA HT 80-100)</p> <p>6 Compressor</p> <p>7 Hot gas by-pass valve</p> <p>8 Condenser</p> <p>9 Condenser fan</p> <p>10 Filter drier</p> | <p>11 Capillary tube</p> <p>12 Temperature probe BT1 – DewPoint</p> <p>13 Condensate drain service valve</p> <p>14 Condensate drain strainer</p> <p>15 Condensate drain solenoid valve</p> <p>16 Coil for condensate drain solenoid valve</p> <p>17 Electronic controller</p> <p>21 BEKOMAT drainer</p> <p>26 Aftercooler</p> <p>27 Aftercooler fan (RA HT 18-100)</p> <p>28 Pre-Filter</p> <p>37 Pressure transducer BP2</p> |
|--|---|

11.4 Refrigerating compressor

The employed refrigerating compressors are constructed by leading manufacturers. The hermetically sealed construction is absolutely gastight. The integrated safeguard protects the compressor against overheating and excess current. The protection is automatically reset as soon as the nominal conditions are reached again.

11.5 Condenser

The condenser is the component in which the gas coming from the compressor is cooled down, condensed and liquefied. Under no circumstances must the temperature of the ambient air exceed the nominal values. It is also important that the condenser unit is kept free from dust and other impurities.

11.6 Aftercooler

The aftercooler is the element where the incoming hot air undergoes the cooling stage. Mechanically, it is formed by a copper tubing circuit (with the compressed air flowing inside) immersed in an aluminium blades package. The cooling operation occurs via a high efficiency axial ventilator which, in applying pressure on the air contained within the dryer, forces it into the blades package. In models RA HT 5-12 the aftercooler is combined with the dryer's condenser, thus forming just one heat exchanger battery, cooled by just one high efficiency axial fan.

It is mandatory that the temperature of the ambient air will not exceed the nominal values of the dryer. It is also important **TO KEEP THE UNIT FREE FROM DUST AND OTHER IMPURITIES** taken in by the fan.

11.7 Pre-Filter (1 micron)

Positioned at the outlet of the aftercooler, it assures a good air cleanliness level, in addition to the complete removal of the water condensed in the aftercooler. **REPLACE THE FILTERING ELEMENT (CARTRIDGE) AT LEAST EVERY 12 MONTHS.**

11.8 Filter dryer

Despite controlled vacuuming, traces of moisture can accumulate in the refrigeration cycle. The filter dryer serves to absorb this moisture and to bond it.

11.9 Capillary tube

The capillary tube is a copper tube with a reduced diameter which is located between the condenser and the evaporator, serving as a restrictor to reduce the pressure of the refrigerant. The pressure reduction serves to reach an optimum temperature inside of the evaporator. The lower the outlet pressure at the capillary tube, the lower the evaporation temperature.

The length and the inner diameter of the capillary tube are exactly dimensioned to ensure the performance of the dryer. Settings or maintenance works are not required.

11.10 Aluminium heat exchanger

The heat exchanger module consists of an air/air heat exchanger, an air/refrigerant heat exchanger, and of a high-performance separator. The compressed air flows top-down through the heat exchanger. The large cross-sections of the flow passages cause low flow rates and low compressed-air losses. In the air/air heat exchanger, the heat exchange is effected in a reverse current. This guarantees maximum heat transfer. The heat transfer in the air/refrigerant heat exchanger also takes place in a reverse current. This allows full evaporation of the refrigerant. The high-performance separator ensures almost complete separation of the condensate. Maintenance of the high-performance separator is not required.

11.11 Hot-gas bypass valve

At partial load, the valve directly returns a part of the hot gas to the suction line of the refrigerating compressor. The evaporation temperature and the evaporation pressure remain constant.



ADJUSTMENT

The hot gas by-pass valve is adjusted during the manufacturing testing phase. As a rule no adjustment is required; anyway if it is necessary the operation must be carried out by an experienced refrigerating engineer.

WARNING

the use of 1/4" Schrader service valves must be justified by a real malfunction of the refrigerating system. Each time a pressure gauge is connected, a part of refrigerant is exhausted.

Without compressed air flow through the dryer, rotate the adjusting screw (position A on the drawing) until the following value is reached:

- Hot gas setting : R134.a pressure 2.2 barg (+0.1 / -0 bar)
- R407C pressure 4.7 barg (+0.1 / -0 bar)

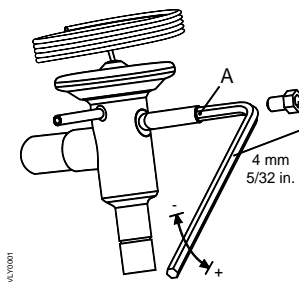

11.15 Electronic controller DMC34

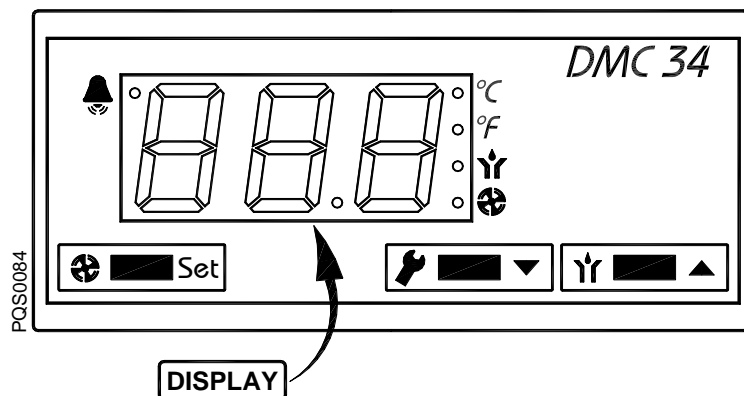

- °C Led - Temperature in °C
- °F Led - Temperature in °F
- Y Led – Drain ON
- F Led – Fan ON
- B Led – Alarm/Service
- Button – Setup menu access / Condensing
- Button – Decrease / Service
- Button – Increase / Drain test

The DMC34 displays DewPoint temperature, controls the condenser fan activation, handles a service reminder and keep record of the total hours of operation of the dryer.

11.15.1 How to switch on the dryer

Power the dryer and switch it on using the ON-OFF switch (pos. 1 paragraph 7.1).

During normal operation the display shows the DewPoint temperature.

The condensate drain test is always active using the button .

11.15.2 How to switch off the dryer

Switch it off using the ON-OFF switch (pos. 1 paragraph 7.1).

11.15.3 How to display the operating parameters

During normal operation, the display shows the DewPoint temperature (in °C or °F).

Press and hold button to display condensing pressure.

Press and hold button to display hours until the next service.

Press and hold + buttons to display total hours of operation of the dryer (cannot be reset).

NOTE : with led ○ °C on temperatures are in °C and pressure in barg; with led ○ °F on temperatures are in °F and pressure in psig.

The total hours of operation and the hours until the next service are shown in the field 0...999 hours and in thousands of hours from 01.0 hours on (example : if the display shows number 35 it means 35 hours; if the display shows number 3.5 it means 3500 hours).

11.15.4 How a service warning / alarm is displayed

A service warning / alarm is an unusual event that must recall the attention of the operators/maintenance technicians. It does not stop the dryer.

When a service warning / alarm is active, the led is lighted or flashing.

Service warnings / alarms are automatically reset as soon as the problem is solved and dryer is powered again. Scheduled Service reminder requires manual reset.

NOTE: the operator/maintenance technician must inspect the dryer and verify/solve the problem that generated the service warning.

Service Warning / Alarm	Description
flashing + PF 1 on display	PF1 - Probe 1 Failure : failure temperature probe BT1
flashing + PF 2 on display	PF2 - Probe 2 Failure : failure pressure probe BP2
flashing + HdP on display	HdP - High DewPoint: DewPoint too high Set BT1>HdS, delay Hdd / Reset BT1<HdS-1°C (HdS-2°F)
flashing + LdP on display	LdP - Low DewPoint : DewPoint too low Set BT1< -1°C (30°F), delay 5 minutes / Reset T1> 1°C (34°F)
flashing + SrV on display	SrV - Service : maintenance service time expired SrV

Technical description

11.15.5 How is controlled the condenser fan

A pressure probe BP2 is located on the discharge side of the compressor. The condenser fan is activated (ON) when the BP2 pressure is higher than FANon setting (R134a approx. 11 barg/160 psig – R407C approx. 18 barg/260 psig) and led  is ON. Condenser fan stops when BP2 pressure is lower than FANoff setting (R134a approx. 8 barg/115 psig – R407C approx. 14 barg/203 psig).

11.15.6 How is controlled the drain solenoid valve

Drain solenoid valve is activated (ON) for *t_{on}* seconds (standard 2 seconds) every *t_{of}* minutes (standard 1 minute). Led  shows that condensate drain solenoid valve is ON.

The condensate drain test is always active using the button .

NOTE : if an electronic drainer is installed, DMC34 is set to keep always powered the drain output (*t_{on}* = ON).

11.15.7 How to reset the service reminder timer

With dryer OFF keep pressed buttons  + , power the dryer and switch it on using the ON-OFF switch (pos.1 paragraph 7.1).

After 5 seconds display shows *SrL*, release buttons  + , keep pressed button  for 5 seconds. Timer has been reset and controller start to operate regularly.

Service reminder timing can be reset at any time, even before the timing has expired.

11.15.8 Operation of the failure / alarm dry contact

The DMC34 is equipped with a dry contact (potential free) to display failure and/or alarm conditions.

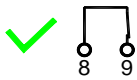

Dryer powered and no service warning / alarm is active.

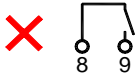



Dryer not powered or service warning / alarm is active.

11.15.9 How to change the operating parameters





The setup menu can be used to change the dryer's operating parameters.





Only qualified personnel must be allowed to access to the setup menu. The manufacturer is not responsible for malfunctioning or failure due to modification to the operating parameters.

With dryer ON simultaneously press buttons  +  for at least 5 seconds to enter the setup menu.

Access to the menu is confirmed by message *t_{on}* on the display (first parameter of menu).

Keep  pressed to display the value of the selected parameter and use arrows  and  to change the value. Release the button  to confirm the value and skip to following parameter.

Press  +  to exit setup menu (if no button is pressed after 2 minutes the menu is exited automatically).

ID	Description	Limits	Resolution	Standard setup
<i>t_{on}</i>	Ton – drain time ON : time ON condensate drain valve ON = Electronic drainer installed	ON 00 ... 20 sec	1 sec	2
<i>t_{of}</i>	ToF - drain time OFF : pause time for condensate drain valve	1 ... 20 min	1 min	1
<i>HdS</i>	HdS – High DewPoint Setting : Alarm threshold for a high DewPoint (the alarm disappears when the temperature drop 1°C / 2°F below alarm point)	0.0...25.0 °C or 32 ... 77 °F	0.5 °C or 1 °F	20 or 68
<i>Hdd</i>	Hdd - High DewPoint Delay : high DewPoint alarm enable delay	01 ... 20 minutes	1 min	15
<i>SrL</i>	SrV - Service Setting: setting of service warning timer. 00 = service warning timer disabled.	00.0 ... 20.0 (x 1000) hours	0.5 (x1000) hours	08.0
<i>SrC</i>	SrC – Service Contact : configuration of the alarm dry contact for the service warning timer. YES = activate the contact / NO = NOT activate the contact	YES / NO	-	YES
<i>SCL</i>	SCL - Scale: display scale of temperatures and pressure (°C = temperatures in °C and pressure in barg; °F = temperatures in °F and pressure in psig)	°C ... °F	-	°C

11.16 Electronically level-controlled BEKOMAT condensate drain

The electronically level-controlled BEKOMAT condensate drain boasts a special condensate management which ensures that condensate is discharged safely and without an unnecessary loss of compressed air. This drain has a condensate collection container in which a capacitive sensor continuously monitors the liquid level. As soon as the switching level is reached, the capacitive sensor transmits a signal to the electronic control and a membrane solenoid valve opens to discharge the condensate. The BEKOMAT closes before compressed air emerges.



Note!

These BEKOMAT condensate drains were designed in particular for the operation in a **DRYPOINT RA HT** refrigeration dryer. The installation in other compressed-air processing systems or the replacement with another drain brand can lead to malfunction. The maximum operating pressure (see type plate) must not be exceeded!

Ensure that the upstream valve is open when the dryer starts operation.

To obtain detailed information regarding drain functions, troubleshooting, maintenance and spare parts, please read the installation and operating instructions of the BEKOMAT condensate drain.

12 Maintenance, troubleshooting, spare parts and dismantling

12.1 Checks and maintenance



Certified skilled personnel

Installation works must exclusively be carried out by authorised and qualified skilled personnel. Prior to undertaking any measures on the DRYPOINT® RA HT 5-100 compressed-air refrigeration dryer, the certified skilled personnel³ shall read up on the device by carefully studying the operating instructions. The operator is responsible for the adherence to these provisions. The respective directives in force apply to the qualification and expertise of the certified skilled personnel.

For safe operation, the device must only be installed and operated in accordance with the indications in the operating instructions. In addition, the national and operational statutory provisions and safety regulations, as well as the accident prevention regulations required for the respective case of application, need to be observed during employment. This applies accordingly when accessories are used.



Danger!

Compressed air!

Risk of serious injury or death through contact with quickly or suddenly escaping compressed air or through bursting and/or unsecured plant components.

Compressed air is a highly dangerous energy source.

Never work on the dryer when the system is under pressure.

Never direct the compressed-air outlet or condensate drain hoses at persons.

The user is responsible for the proper maintenance of the dryer. Non-observance of the instructions in the "Installation" and "Maintenance, troubleshooting, spare parts and dismantling" chapters leads to the expiration of the guarantee. Improper maintenance may result in dangerous situations for the personnel and/or the device.



Danger!

Supply voltage!

Contact with non-insulated parts carrying supply voltage involves the risk of an electric shock resulting in injuries and death.

Only qualified and skilled personnel are authorised to run electrically-operated devices. Prior to undertaking maintenance measures at the device, the following requirements must be met:

Make sure that the power supply is switched off and that the device is off and marked for maintenance measures. Please also ensure that the power supply cannot be re-established during the works.



Prior to carrying out maintenance works at the dryer, switch it off and wait for at least 30 minutes.



Caution!

Hot surfaces!

During operation, several components can reach surface temperatures of more than +60°C. There is the risk of burns.

All components concerned are installed inside of the closed housing. The housing must only be opened by certified skilled personnel.

Some components can reach high temperatures during operation. Avoid any contact until the system or the component has cooled down.

³ Certified skilled personnel are persons who are authorised by the manufacturer, with experience and technical training, who are well-grounded in the respective provisions and laws and capable of carrying out the required works and of identifying and avoiding any risks during the machine transport, installation, operation and maintenance. Qualified and authorised operators are persons who are instructed by the manufacturer regarding the handling of the refrigeration system, with experience and technical training, and who are well-grounded in the respective provisions and laws.

**DAILY:**

- Check whether the dew point indicated on the electronics is correct.
- Ensure that the condensate drain system functions properly.
- Make sure that the condenser is clean.

EVERY 200 HOURS OR MONTHLY

- Clean the condenser using an air jet (max. 2 bar / 30 psig) inside out. Make sure not to damage the aluminium lamellae of the cooling package.
- Finally, verify the operation of the device.

EVERY 1,000 HOURS OR ANNUALLY

- Verify all screws, clamps and connections of the electric system to make sure that they are fastened securely. Check the device for broken and ruptured cables or cables without insulation.
- Check the refrigeration cycle for signs of oil and refrigerant leaks.
- Measure the current strength and note it down. Ensure that the read values are within the permissible limit values, as indicated in the specification table.
- Check the hose lines of the condensate drain and replace them, if required.
- Replace the filter element (cartridge) of the Pre-Filter (1 micron). Refer to the instructions in the user's and maintenance manual of the filter for this operation.
- Finally, verify the operation of the device.

**EVERY 8,000 HOURS**

- Replace BEKOMAT Service Unit.

12.2 Troubleshooting**Certified skilled personnel**

Installation works must exclusively be carried out by authorised and qualified skilled personnel. Prior to undertaking any measures on the DRYPOINT® RA HT 5-100 compressed-air refrigeration dryer, the certified skilled personnel shall read up on the device by carefully studying the operating instructions. The operator is responsible for the adherence to these provisions. The respective directives in force apply to the qualification and expertise of the certified skilled personnel.

For safe operation, the device must only be installed and operated in accordance with the indications in the operating instructions. In addition, the national and operational statutory provisions and safety regulations, as well as the accident prevention regulations required for the respective case of application, need to be observed during employment. This applies accordingly when accessories are used.

**Danger!****Compressed air!**

Risk of serious injury or death through contact with quickly or suddenly escaping compressed air or through bursting and/or unsecured plant components.

Compressed air is a highly dangerous energy source.

Never work on the dryer when the system is under pressure.

Never direct the compressed-air outlet or condensate drain hoses at persons.

The user is responsible for the proper maintenance of the dryer. Non-observance of the instructions in the "Installation" and "Maintenance, troubleshooting, spare parts and dismantling" chapters leads to the expiration of the guarantee. Improper maintenance may result in dangerous situations for the personnel and/or the device.

**Danger!****Supply voltage!**

Contact with non-insulated parts carrying supply voltage involves the risk of an electric shock resulting in injuries and death.

Only qualified and skilled personnel are authorised to run electrically-operated devices. Prior to undertaking maintenance measures at the device, the following requirements must be met:

Make sure that the power supply is switched off and that the device is off and marked for maintenance measures. Please also ensure that the power supply cannot be re-established during the works.



Prior to carrying out maintenance works at the dryer, switch it off and wait for at least 30 minutes.



Caution!
Hot surfaces!





During operation, several components can reach surface temperatures of more than +60°C. There is the risk of burns.

All components concerned are installed inside of the closed housing. The housing must only be opened by certified skilled personnel.

Some components can reach high temperatures during operation. Avoid any contact until the system or the component has cooled down.

FAULT	POSSIBLE REASON - SUGGESTED MEASURE
◆ The dryer doesn't start.	<ul style="list-style-type: none"> ⇒ Verify that the system is powered. ⇒ Verify the electric wiring.
◆ The compressor doesn't work.	<ul style="list-style-type: none"> ⇒ Activation of the compressor internal thermal protection - wait for 30 minutes, then retry. ⇒ Verify the electric wiring. ⇒ If installed - Replace the internal thermal protection and/or the start-up relay and/or the start-up capacitor and/or the working capacitor. ⇒ If installed - The pressure switch HPS has been activated - see specific point. ⇒ If installed - The pressure switch LPS has been activated - see specific point. ⇒ If installed - The safety thermo switch TS has been activated - see specific point ⇒ If the compressor still doesn't work, replace it.
◆ Condenser's fan doesn't work.	<ul style="list-style-type: none"> ⇒ Verify the electric wiring. ⇒ The electronic controller is faulty – replace it. ⇒ If installed - Fan relay (see KF on the electric diagram) is faulty - replace it. ⇒ There is a leak in the refrigerant circuit - contact a refrigeration engineer. ⇒ If the fan still doesn't work, replace it.
◆ DewPoint too high.	<ul style="list-style-type: none"> ⇒ The dryer doesn't start - see specific point. ⇒ The DewPoint probe BT1 doesn't correctly detect the temperature - ensure the sensor is pushed into the bottom of probe well. ⇒ The Compressor doesn't work - see specific point. ⇒ The ambient temperature is too high or the room aeration is insufficient - provide proper ventilation. ⇒ The inlet air is too hot - restore nominal conditions. ⇒ The inlet air pressure is too low - restore nominal conditions. ⇒ The inlet air flow rate is higher than the rate of the dryer - reduce the flow rate - restore nominal conditions. ⇒ The condenser is dirty - clean it. ⇒ The condenser fan doesn't work - see specific point. ⇒ The dryer doesn't drain the condensate - see specific point. ⇒ The hot gas by-pass valve is out of setting - contact a refrigeration engineer to restore nominal setting. ⇒ There is a leak in the refrigerant circuit - contact a refrigeration engineer.

FAULT	POSSIBLE REASON - SUGGESTED MEASURE
◆ Dew Point too low	⇒ The fan is always ON – Led  is flashing + display PF2 - see specific point. ⇒ Ambient temperature is too low - restore nominal conditions. ⇒ The hot gas by-pass valve is out of setting - contact a refrigeration engineer to restore nominal setting.
◆ Excessive pressure drop within the dryer.	⇒ The Pre-Filter is clogged - replace the filter element (cartridge 3 micron) - Refer to the instructions in the user's and maintenance manual of the filter. ⇒ The dryer doesn't drain the condensate - see specific point. ⇒ The DewPoint is too low - the condensate is frost and blocks the air - see specific point. ⇒ Check for throttling the flexible connection hoses.
◆ The dryer doesn't drain the condensate	⇒ The condensate drain service valve is closed - open it. ⇒ Condensate strainer is clogged – remove and clean it. ⇒ The drain solenoid valve is jammed – remove and clean it. ⇒ Verify the electric wiring. ⇒ The coil of the drain solenoid valve is failed – replace it. ⇒ Electronic controller is faulty – replace it. ⇒ The DewPoint is too low - the condensate is frost and blocks the air - see specific point. ⇒ Inlet compressed air pressure is too low and condensate is not drained – restore nominal conditions. ⇒ BEKOMAT drainer is not operating correctly (see BEKOMAT MANUAL)
◆ The dryer continuously drains condensate.	⇒ The drain solenoid valve is jammed – remove and clean it. ⇒ Try to remove the electric connector on the solenoid valve - if drain stops verify the electric wiring or the electronic controller is faulty - replace it ⇒ BEKOMAT drainer is dirty (see BEKOMAT MANUAL)
◆ Water within the line.	⇒ The dryer doesn't start - see specific point. ⇒ If installed - Untreated air flows through the by-pass unit - close the by-pass. ⇒ The dryer doesn't drain the condensate - see specific point. ⇒ DewPoint too high - see specific point.
◆ If installed – HPS high pressure switch has been activated.	⇒ Check which of the following has caused the activation : ⇒ The ambient temperature is too high or the room aeration is insufficient - provide proper ventilation. ⇒ The condenser and/or aftercooler is dirty - clean it. ⇒ The condenser and/or aftercooler fan doesn't work - see specific point. ⇒ Reset the pressure switch pressing the button on the controller itself - verify the dryer for correct operation. ⇒ HPS pressure switch is faulty - contact a refrigeration engineer to replace it.
◆ If installed – LPS low pressure switch has been activated.	⇒ There is a leak in the refrigerating fluid circuit - contact a refrigeration engineer. ⇒ The pressure switch reset automatically when normal conditions are restored - check the proper operation of the dryer.

SYMPTOM	POSSIBLE CAUSE - SUGGESTED ACTION
<p>◆ If installed – TS safety thermo switch has been activated.</p>	<p>⇒ Check which of the following has caused the activation :</p> <ol style="list-style-type: none"> 1. Excessive thermal load – restore the standard operating conditions. 2. The inlet air is too hot - restore the nominal conditions. 3. The ambient temperature is too high or the room aeration is insufficient - provide proper ventilation. 4. The condenser and/or aftercooler unit is dirty - clean it. 5. The condenser and/or aftercooler fan doesn't work - see specific point. 6. The hot gas by-pass valve requires re-adjusting – contact a specialized technician to restore nominal setting. 7. There is a leak in the refrigerating fluid circuit - contact a refrigeration engineer. <p>⇒ Reset the thermo switch by pressing the button on the thermo switch itself – verify the correct operation of the dryer.</p> <p>⇒ TS thermo switch is faulty - replace it.</p>
<p>◆ DMC34 – Led  is flashing + display PF1.</p>	<p>⇒ Verify the electric wiring of BT1 DewPoint probe.</p> <p>⇒ The BT1 DewPoint probe is faulty - replace it.</p> <p>⇒ The electronic controller is faulty - replace it.</p>
<p>◆ DMC34 – Led  is flashing + display PF2.</p>	<p>⇒ Verify the electric wiring of BP2 fan control probe.</p> <p>⇒ The BP2 fan control probe is faulty - replace it.</p> <p>⇒ The electronic controller is faulty - replace it.</p>
<p>◆ DMC34 – Led  is flashing + display HdP.</p>	<p>⇒ DewPoint too high - see specific point.</p> <p>⇒ The BT1 DewPoint probe is faulty - replace it.</p> <p>⇒ The electronic controller is faulty - replace it.</p>
<p>◆ DMC34 – Led  is flashing + display LdP.</p>	<p>⇒ DewPoint too low - see specific point.</p> <p>⇒ The BT1 DewPoint probe is faulty - replace it.</p> <p>⇒ The electronic controller is faulty - replace it.</p>
<p>◆ DMC34 – Led  is flashing + display SrL.</p>	<p>⇒ Service reminder timer has expired – dryer requires service.</p> <p>⇒ Perform the proper service to the dryer.</p> <p>⇒ Reset the service reminder timer.</p>

12.3 Recommended spare parts

NOTE: To order the recommended spare parts or other elements, the data on the type plate must be indicated.

ID N.		DESCRIPTION	DP RA HT											
			5	8	12	18	23	30	40	55	60	80	100	
2	LPS	Pressure switch											1	1
3	TS	Safety thermo switch							1	1	1	1	1	1
4	HPS	Pressure switch											1	1
37	BP2	Pressure transducer	1	1	1	1	1	1	1	1	1	1	1	1
6	MC	Compressor	1	1	1	1	1	1	1	1	1	1	1	1
7		Hot gas by-pass valve	1	1	1	1	1	1	1	1	1	1	1	1
8		Condenser	1	1	1	1	1	1	1	1	1	1	1	1
9	MV1	Complete fan											1	1
9.1		Fan motor	1	1	1	1	1	1	1	1	1	1		
9.2		Fan blade	1	1	1	1	1	1	1	1	1	1		
9.3		Fan grid	1	1	1	1	1	1	1	1	1	1		
26		Aftercooler				1	1	1	1	1	1	1	1	1
27	MV2	Aftercooler fan									1	1	1	1
27.1		Fan motor				1	1	1	1					
27.2		Fan blade				1	1	1	1					
27.3		Fan grid				1	1	1	1					
10		Filter drier	1	1	1	1	1	1	1	1	1	1	1	1
12	BT	Temperature probe	1	1	1	1	1	1	1	1	1	1	1	1
13-14		Y strainer	1	1	1	1	1	1	1	1	1	1	1	1
15	EVD 1-2	Condensate drain solenoid valve	2	2	2	2	2	2	2	2	2	2	2	2
16		Coil for condensate drain solenoid valve	2	2	2	2	2	2	2	2	2	2	2	2
17	DMC34	Electronic instrument	1	1	1	1	1	1	1	1	1	1	1	1
21	ELD	BEKOMAT condensate drain	2	2	2	2	2	2	2	2	2	2	2	2
		BEKOMAT service unit	2	2	2	2	2	2	2	2	2	2	2	2
22	S1	Lighted switch	1	1	1	1	1	1	1	1	1	1		
	QS	Main switch											1	1
60	KF	Solid state relay											1	1
28		Fine coalescing filter cartridge	1	1	1	1	1	1	1	1	1	1	1	1

12.4 Maintenance works at the refrigeration cycle



Caution!
Refrigerant!

Maintenance and repair works at refrigeration systems must only be carried out by BEKO service technicians in accordance with the local provisions.

The total amount of refrigerant in the system must be collected for recycling purposes, resource recovery or disposal.

The refrigerant must not be discharged into the environment.

When delivered, the dryer is ready to operate and filled with a refrigerant of the R134a or R407C type.



Should you detect a refrigerant leak, please contact a BEKO service technician. Prior to any intervention, the room needs to be ventilated.

When the refrigeration cycle needs to be refilled, please also contact a BEKO service technician.

You will find the refrigerant type and amount on the type plate of the dryer.

Properties of the refrigerants used:

Refrigerant	Chemical formula	MIK	GWP
R134a - HFC	CH ₂ FCF ₃	1000 ppm	1430
R407C - HFC	R32/125/134a (23/25/52) CHF ₂ CF ₃ /CH ₂ F ₂ /CH ₂ FCF ₃	1000 ppm	1773.85

12.5 Dismantling the dryer

When the dryer is dismantled, all parts and operating materials related to the plant need to be disposed of separately.



Component	Material
Refrigerant	R407C, R134a, oil
Roof and supports	Structural steel, epoxy paint coat
Refrigerating compressor	Steel, copper, aluminium, oil
Aluminium heat exchanger	Aluminium
Condenser unit	Aluminium, copper, structural steel
Pipe	Copper
Fan	Aluminium, copper, steel
BEKOMAT condensate drain	PVC, aluminium, steel
Insulant	Synthetic rubber without CFCs, polysterene, polyurethane
Electric cable	Copper, PVC
Electric parts	PVC, copper, brass



We recommend observing the safety provisions in force for the disposal of each material type.

The refrigerant contains lubricating-oil droplets which are released by the compressor.

The refrigerant must not be discharged into the environment. It must to be sucked off from the dryer using a suitable device, and then needs to be supplied to a collection point.

13 Appendices

13.1 Dryer dimensions

13.1.1 Dryer dimensions DRYPOINT RA HT 5-12

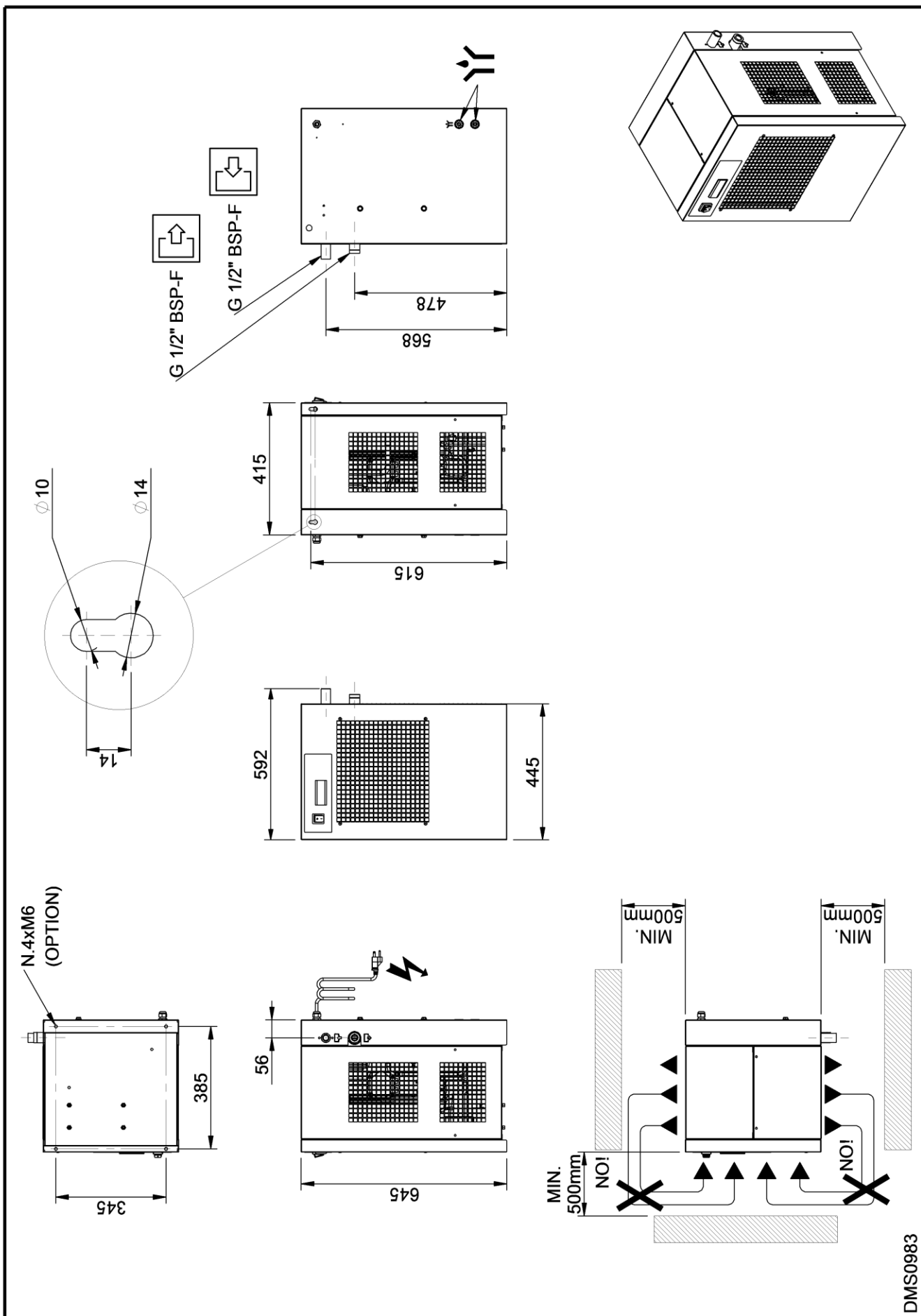

DMS0983

13.1.2 Dryer dimensions DRYPOINT RA HT 18-23

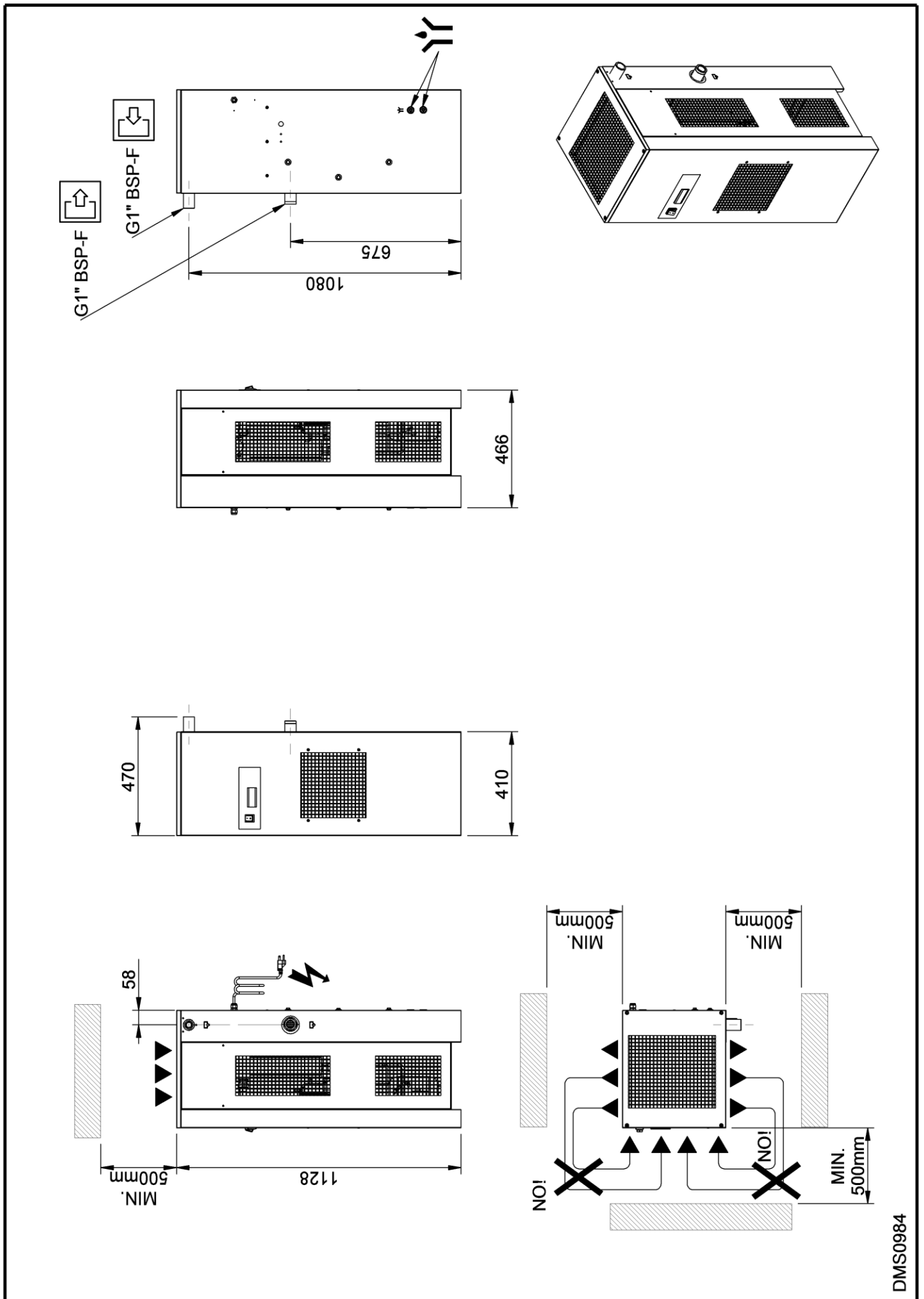

DMS0984

13.1.3 Dryer dimensions DRYPOINT RA HT 30-40

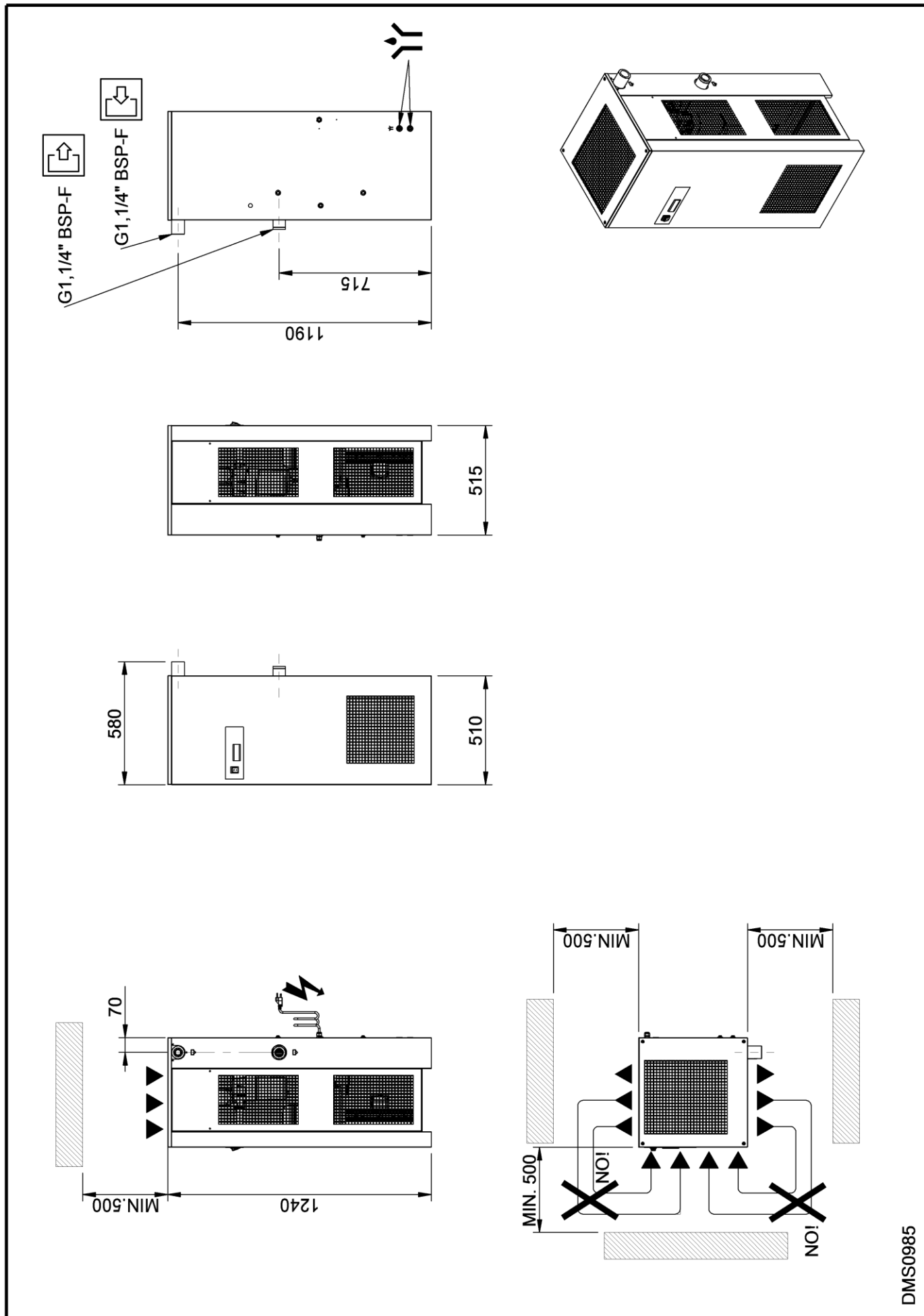

DMS0985

13.1.4 Dryer dimensions DRYPOINT RA HT 55-60

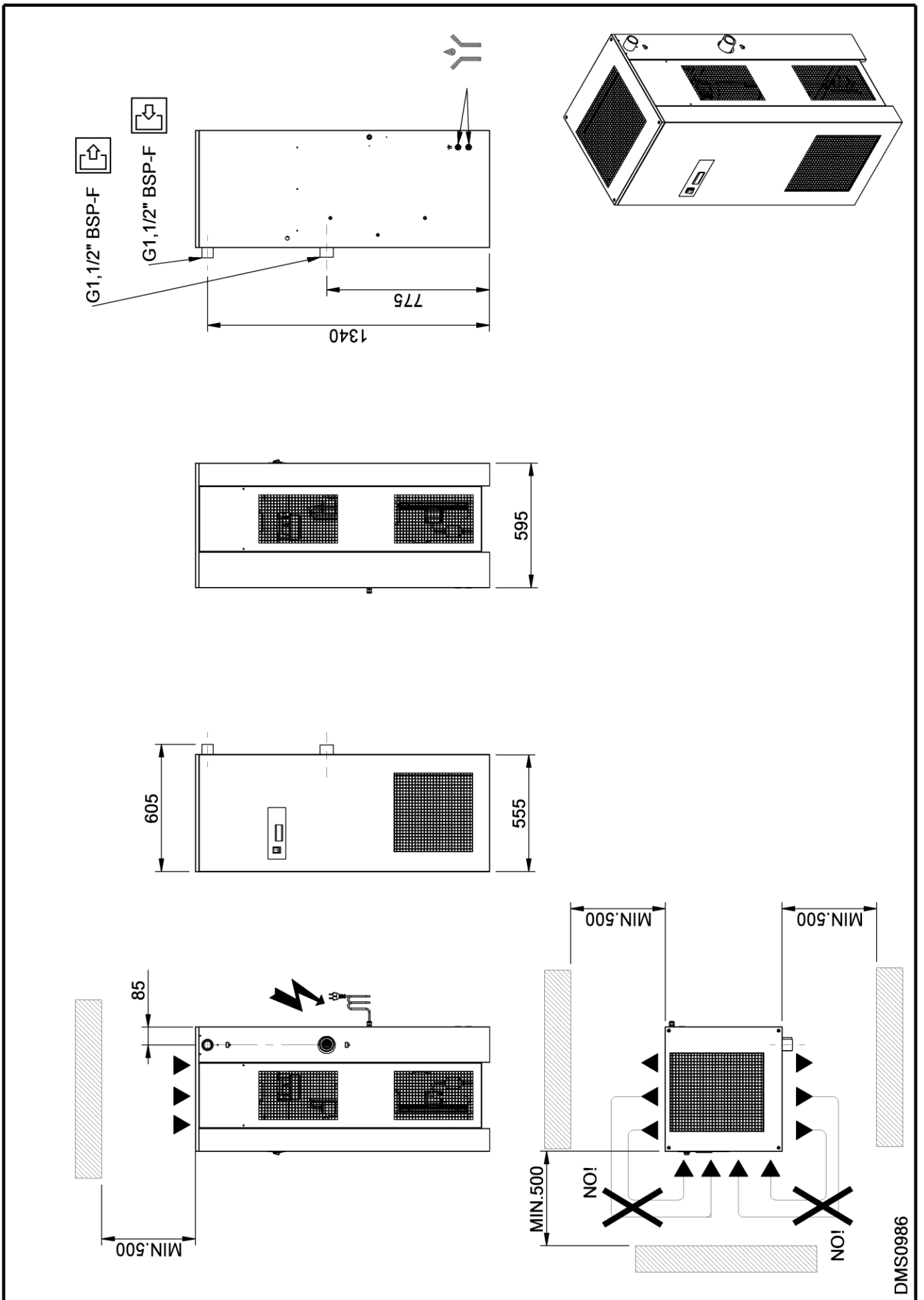

13.1.5 Dryer dimensions DRYPOINT RA HT 80-100

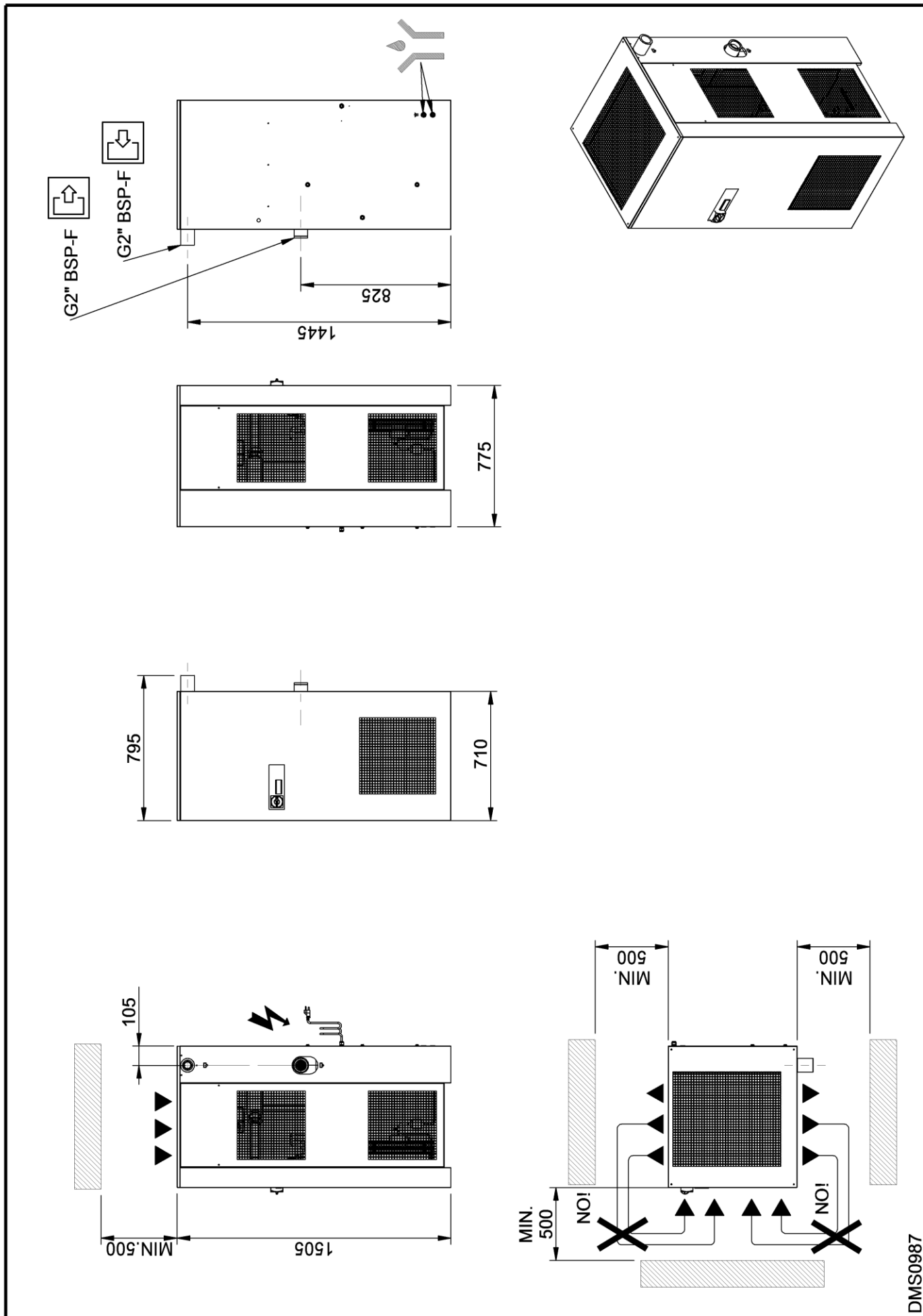

DMS0987

13.2.1 Components of the exploded diagrams

1	Alu-Dry module	22	Main switch
1.1	Insulation material	26	Aftercooler
2	Refrigerant pressure switch LPS	27	Aftercooler fan
3	Safety thermo switch TS	27.1	Motor
4	Refrigerant pressure switch HPS	27.2	Blade
6	Compressor	27.3	Grid
7	Hot-gas bypass valve	28	Pre-filter
8	Condenser	37	Pressure transducer BP2
9	Condenser fan	51	Front panel
9.1	Motor	52	Back panel
9.2	Blade	53	Right lateral panel
9.3	Grid	54	Left lateral panel
10	Filter drier	55	Cover
11	Capillary tube	56	Base plate
12	Temperature probe BT1	57	Upper plate
13	Condensate drain service valve	58	Support beam
14	Condensate drain strainer	59	Support bracket
15	Condensate drain solenoid valve	60	Control panel
16	Coil for condensate drain solenoid valve	61	Electric connecting plug
17	Electronic controller	81	Flow diagram sticker
21	BEKOMAT drainer		

13.2.2 Exploded diagram DRYPOINT RA HT 5-18

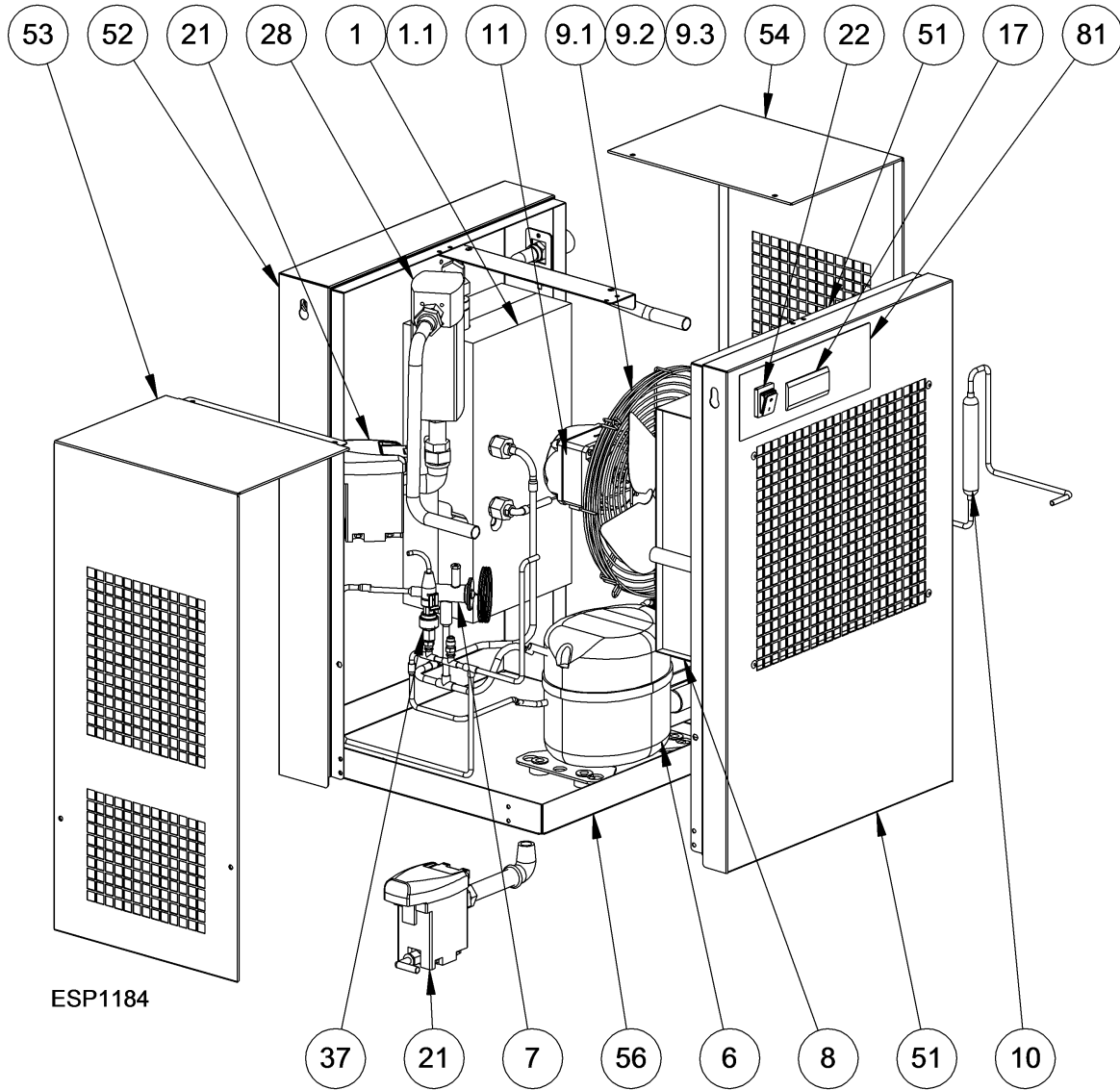

13.2.3 Exploded diagram DRYPOINT RA HT 23

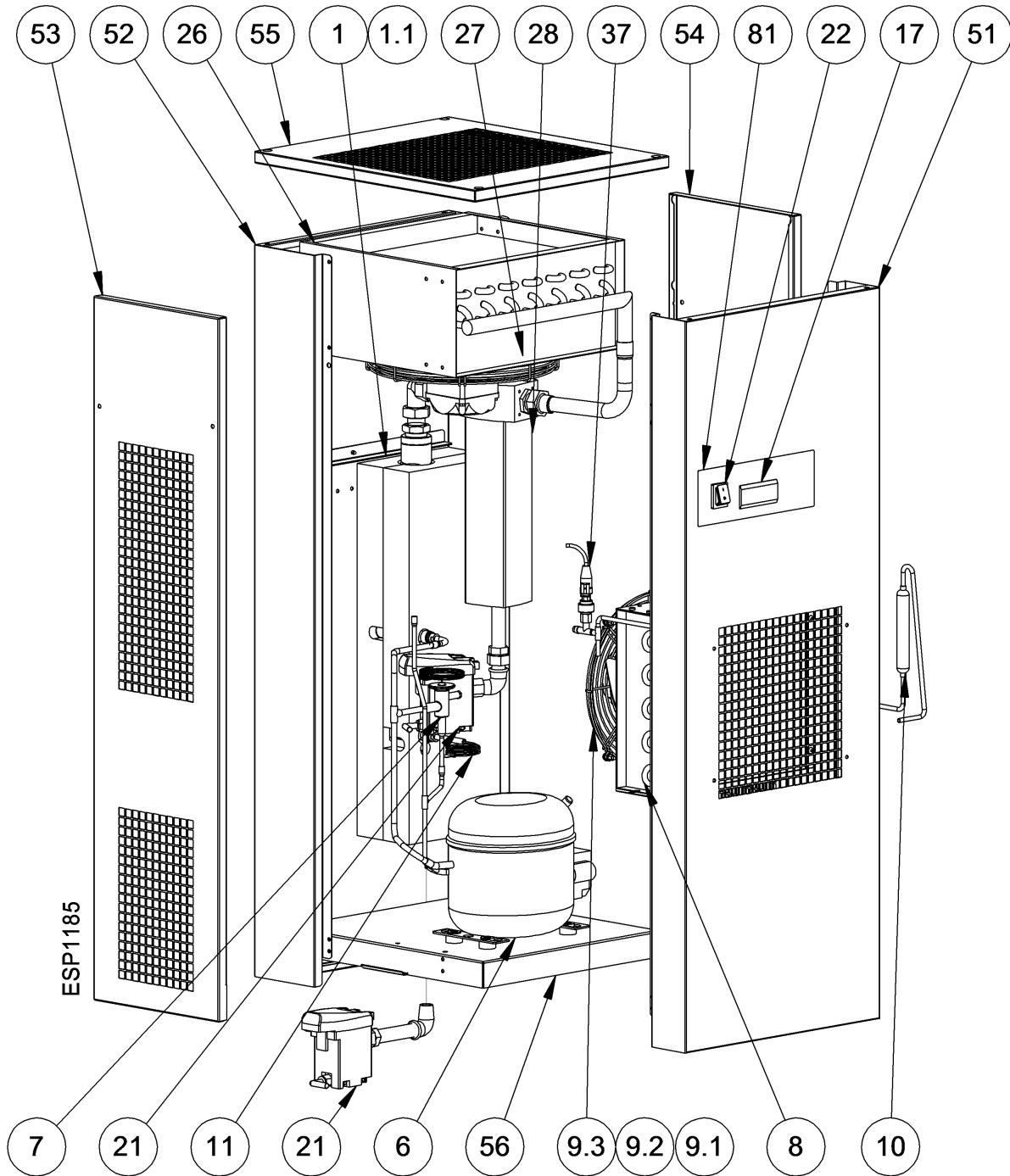

13.2.4 Exploded diagram DRYPOINT RA HT 30

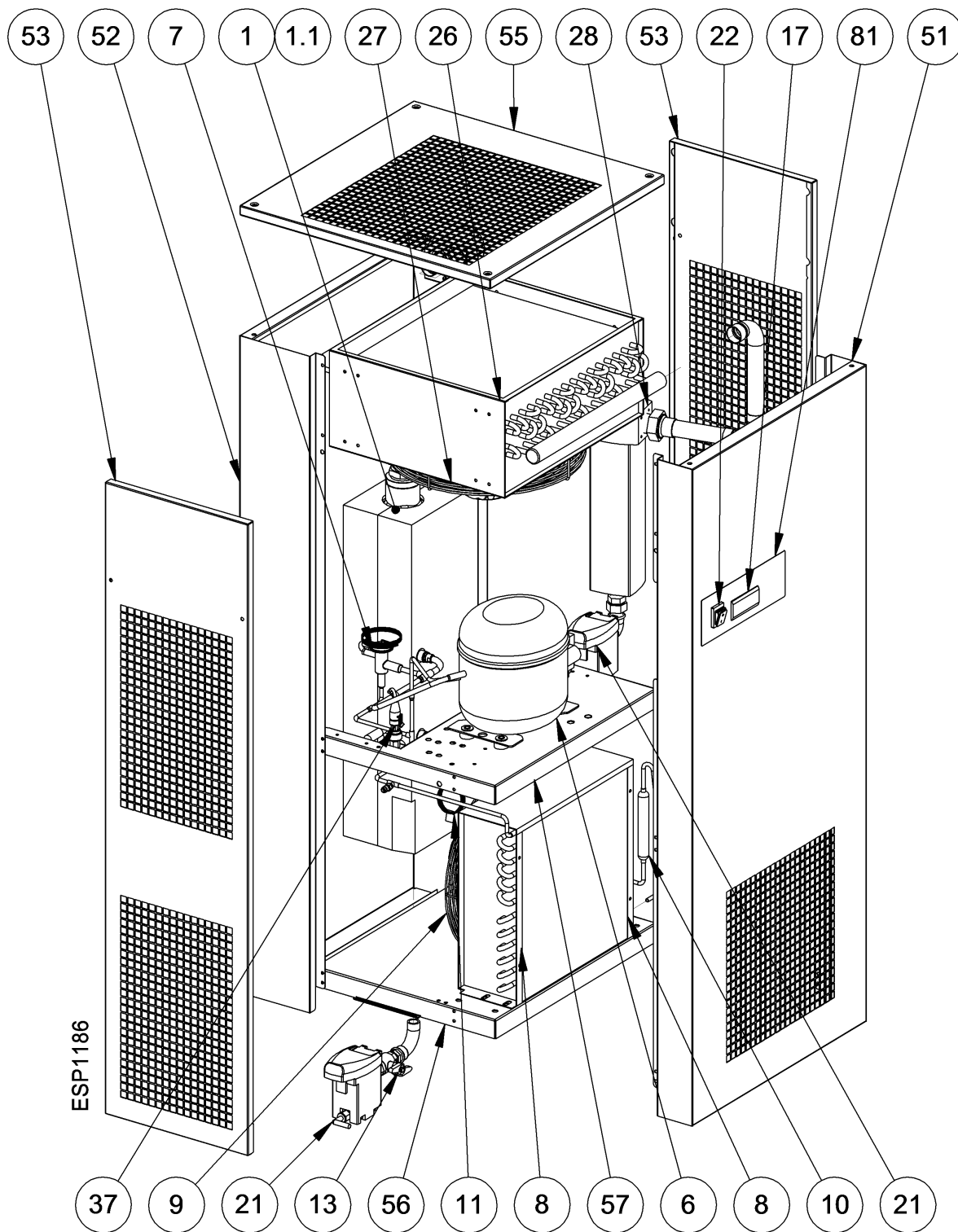

13.2.5 Exploded diagram DRYPOINT RA HT 40-55

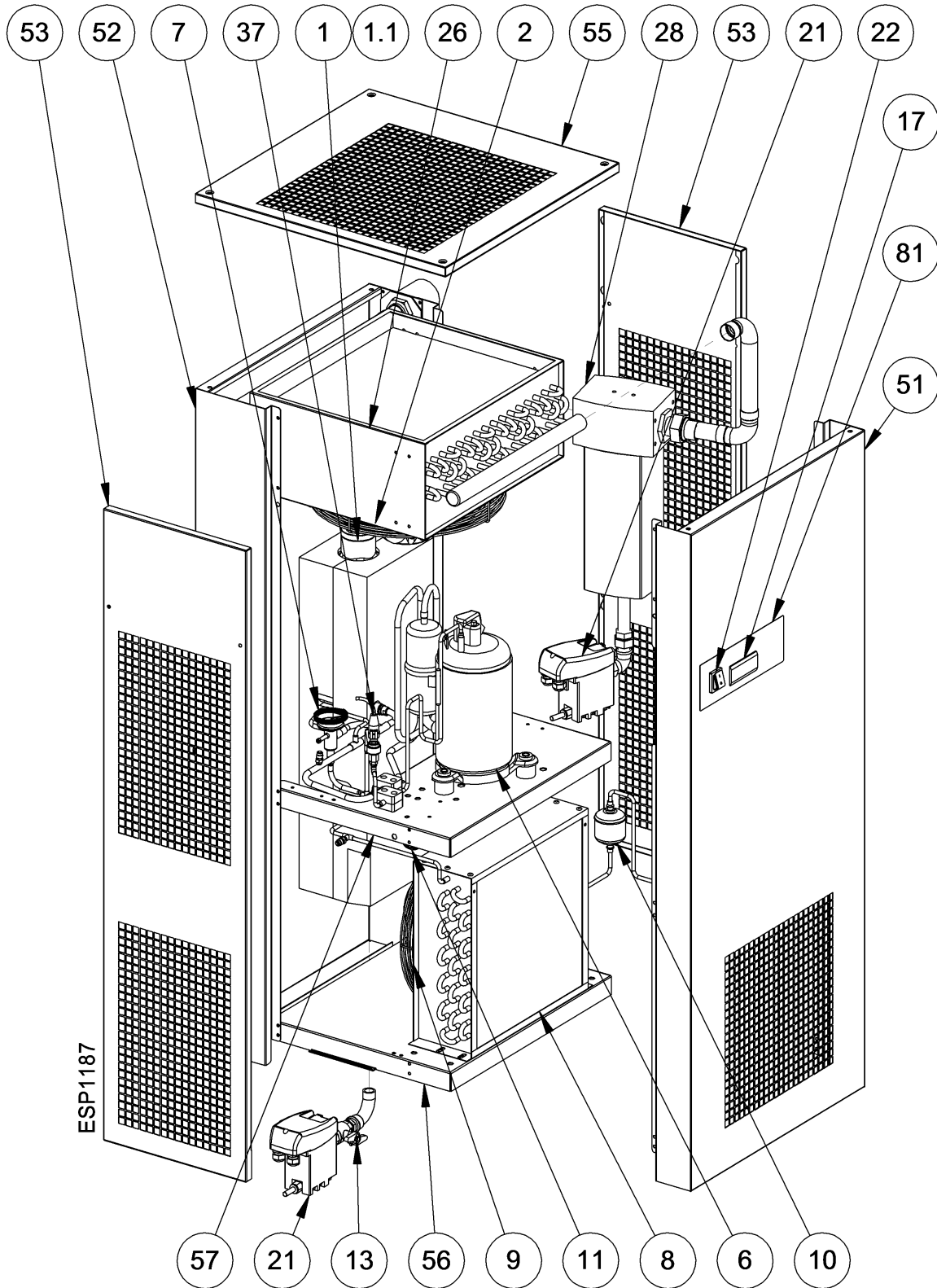

13.2.6 Exploded diagram DRYPOINT RA HT 80-100

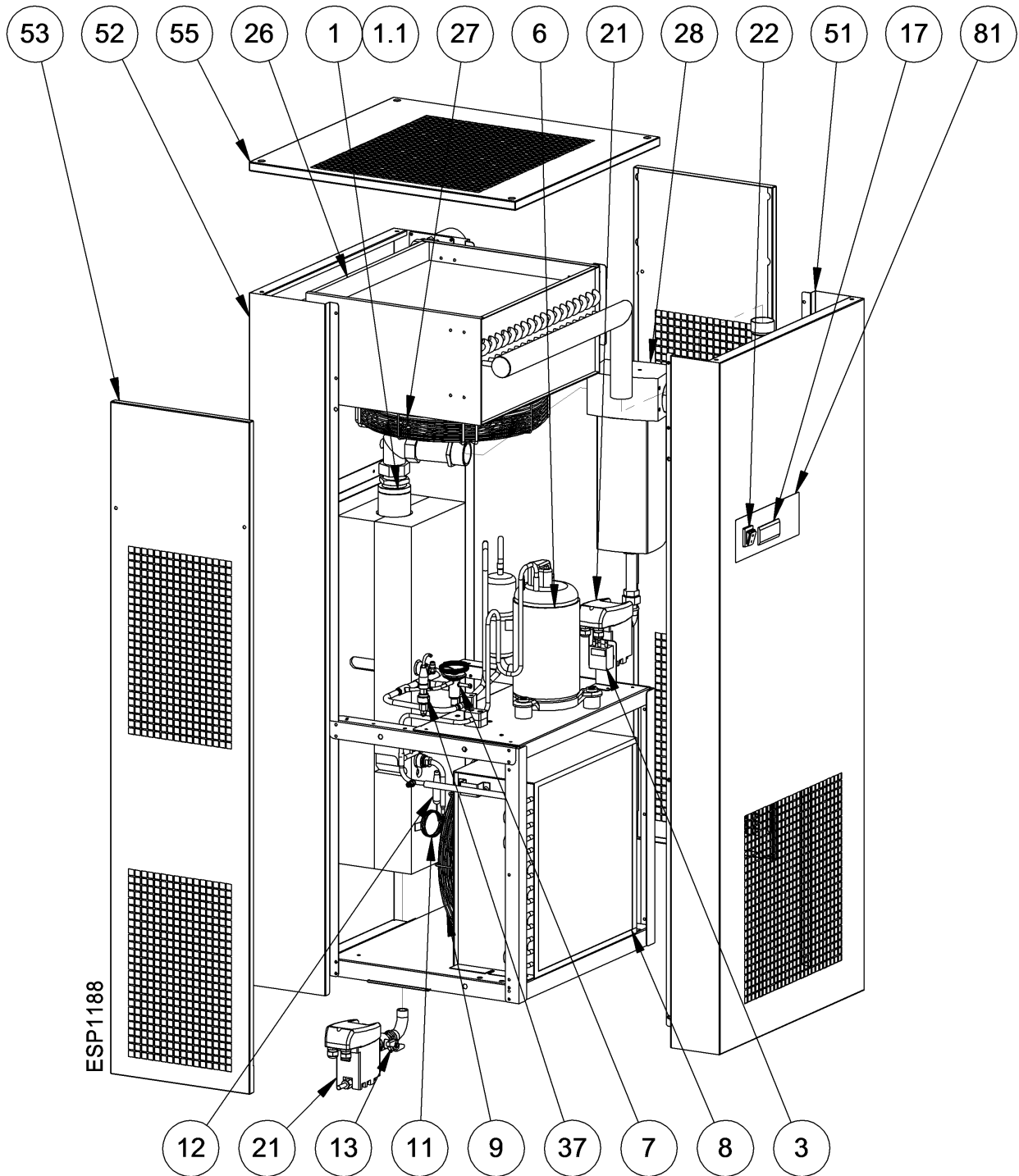

13.3 Electric diagrams

13.3.1 Electric diagrams – list of components

- MC1** : Compressor
 - KT** : Compressor thermal protection
 - KR** : Compressor starting relay
 - CS** : Compressor starting capacitor
 - CR** : Compressor operating capacitor
- MV1** : Condenser fan
- MV2** : Aftercooler fan
 - KV** : Fan thermal protection
 - CV** : Fan starting capacitor (if installed)
- DMC34** : Electronic controller
- BT1** : T1 Temperature probe – dew point
- BT2** : T2 Temperature probe – compressor discharge
- HPS** : Pressure switch – compressor discharge side (HIGH PRESSURE)
- LPS** : Pressure switch – compressor suction side (LOW PRESSURE)
- EVD 1-2** : Timed condensate drain solenoid valve
- ELD 1-2** : BEKOMAT drain
 - S1** : ON/OFF switch

- NT2** : Verify transformer connection according to power supply voltage
- NT3** : Jump if not installed
- NT4** : Provided and wired by customer
- NT5** : Limit of equipment
- NT6** : Timed drain output

- BN** = BROWN **OR** = ORANGE
- BU** = BLUE **RD** = RED
- BK** = BLACK **WH** = WHITE
- YG** = YELLOW/GREEN **WH/BK** = WHITE/BLACK

13.3.2 Electric diagram DRYPOINT RA HT 5-12

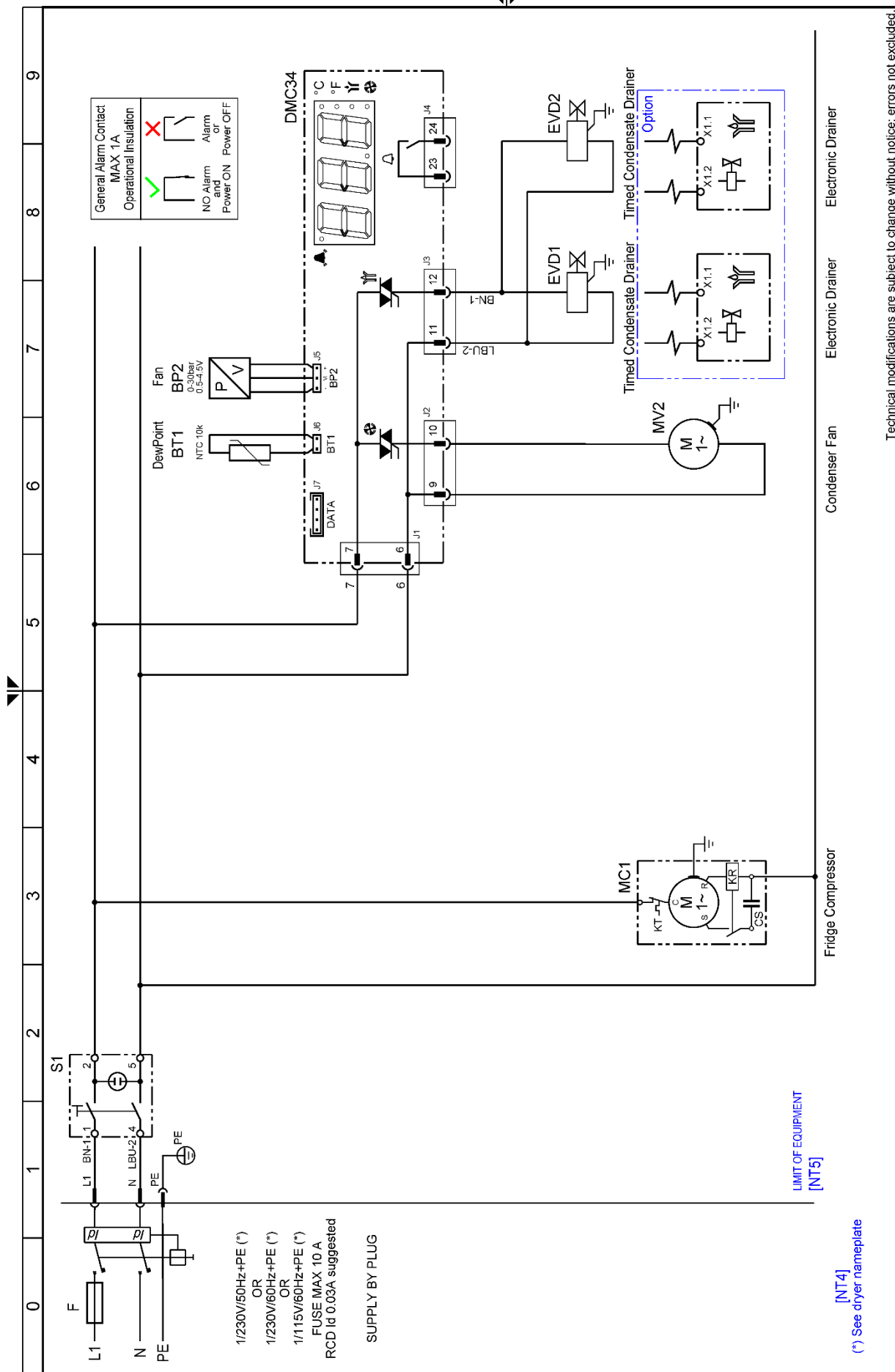

Technical modifications are subject to change without notice; errors not excluded.

Rev. 00
 Drawing no.: WD021_V00
 Note: .

Sheet 01 of 01

13.3.3 Electric diagram DRYPOINT RA HT 18-23

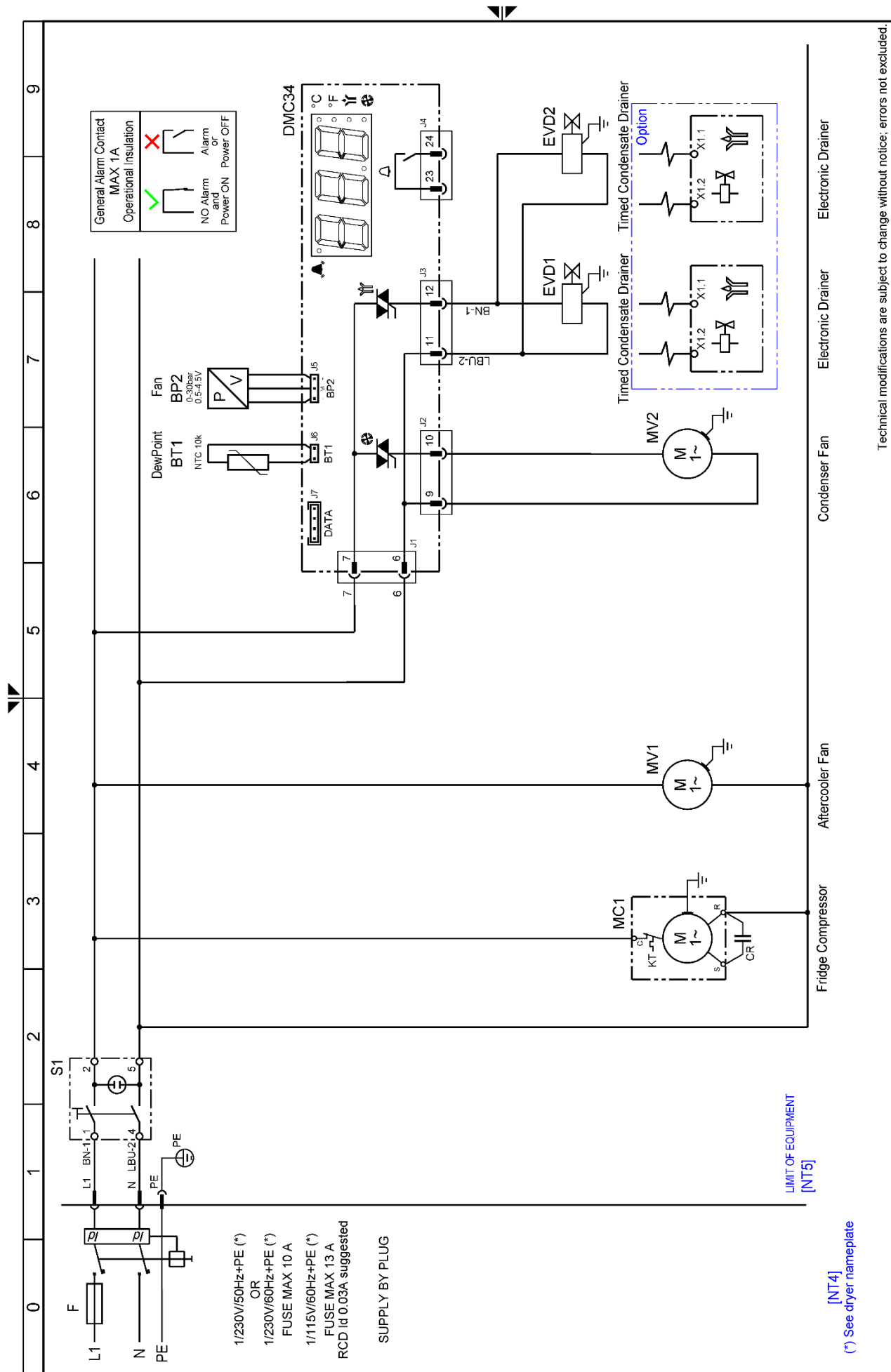

Technical modifications are subject to change without notice; errors not excluded.

Rev. 00
 Drawing no.: WD022_V00
 Note: .

13.3.5 Electric diagram DRYPOINT RA HT 40

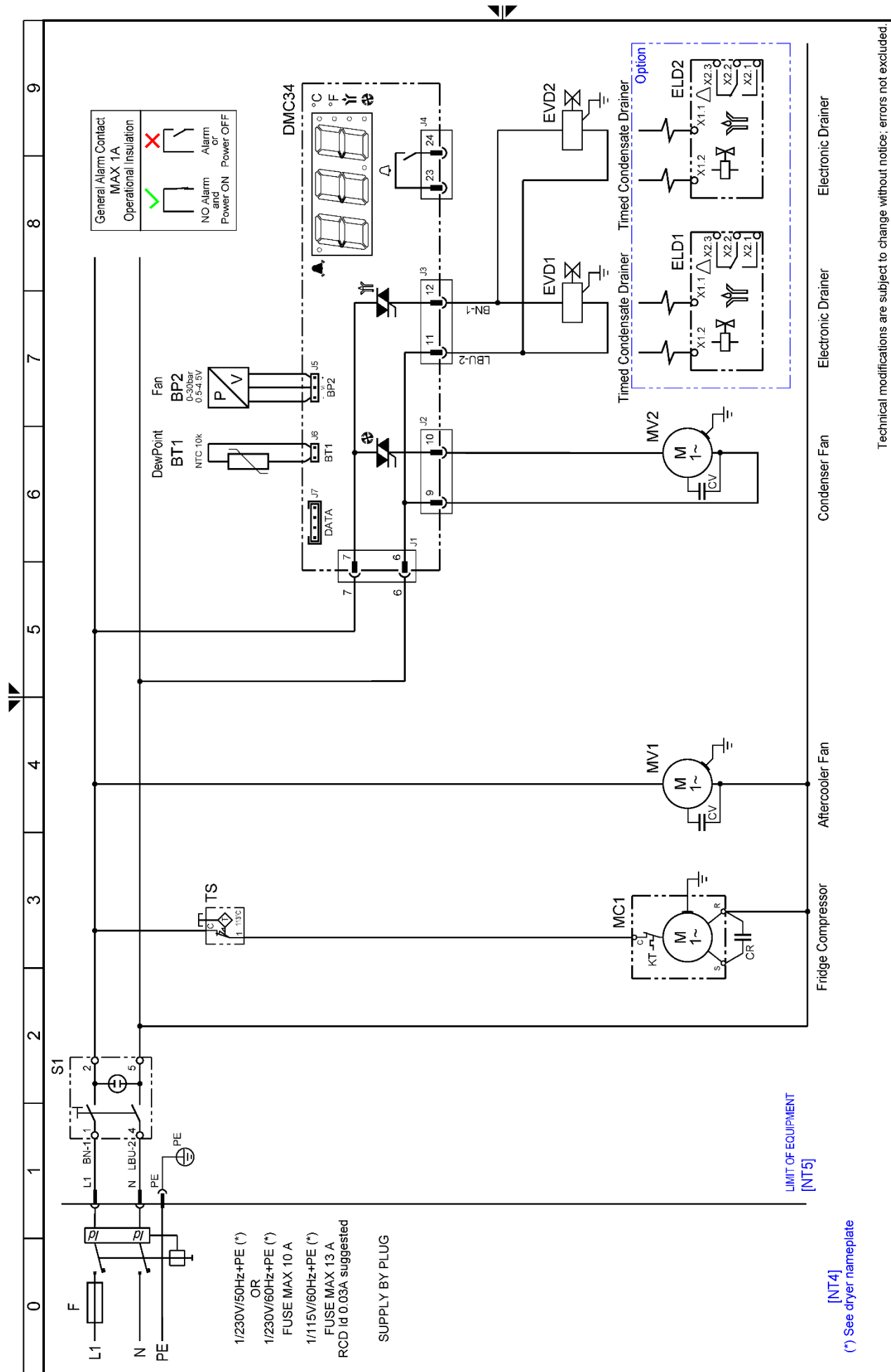

[NT4] (*) See dryer nameplate

Technical modifications are subject to change without notice, errors not excluded.

Rev. 00

Drawing no. : WD023_V00

Note :

Sheet 01 of 01

13.3.6 Electric diagram DRYPOINT RA HT 55-60

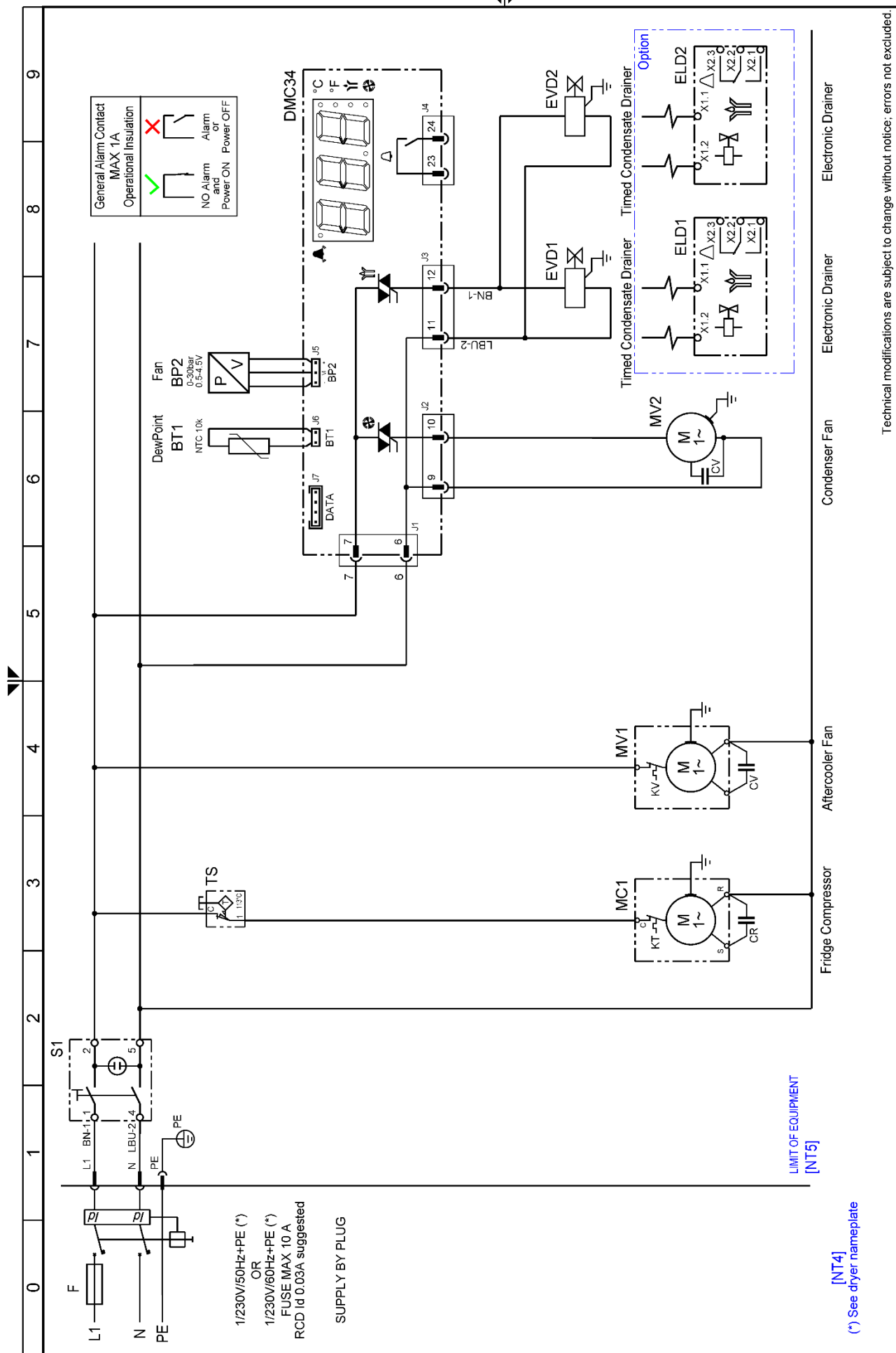

Technical modifications are subject to change without notice; errors not excluded.
 Drawing no. : **WD024_V00**
 Rev. **00**
 Note :
 Sheet **01** of **01**

14 Declaration of conformity

BEKO TECHNOLOGIES GMBH
Im Taubental 7
41468 Neuss

GERMANY

Tel: +49 2131 988-0
www.beko-technologies.com



EU-Konformitätserklärung

Wir erklären hiermit, dass die nachfolgend bezeichneten Produkte den Anforderungen der einschlägigen Richtlinien und technischen Normen entsprechen. Diese Erklärung bezieht sich nur auf die Produkte in dem Zustand, in dem sie von uns in Verkehr gebracht wurden. Nicht vom Hersteller angebrachte Teile und/oder nachträglich vorgenommene Eingriffe bleiben unberücksichtigt.

Produktbezeichnung:	DRYPOINT® RA HT
Modelle:	35, 50, 70, 110, 135, 190, 240, 330, 370, 490, 630
Spannungsvarianten:	≥ 110 VAC
Max. Betriebsdruck:	35 - 70: 16 bar (g) 110 - 630: 14 bar (g)
Produktbeschreibung und Funktion:	Kältetrockner zur Herabsetzung des Drucktaupunkts in Druckluft

Maschinen-Richtlinie 2006/42/EG

Angewandte harmonisierte Normen:	EN 14119, EN 14120, EN 12100, EN 13849-1, EN 60204-1
Name des Dokumentationsbevollmächtigten:	Herbert Schlensker Im Taubental 7 41468 Neuss Deutschland

Druckgeräte-Richtlinie 2014/68/EU

Angewandte harmonisierte Normen:	ASME VIII Div. 1, EN 378-2, EN 10028-3, EN 12451
Angewandtes Konformitätsbewertungsverfahren:	240 - 630: Modul A

Die Produkte 35-190 fallen in keine Druckgerätekategorie und sind gemäß Artikel 4 Absatz 3 in Übereinstimmung mit der in den Mitgliedstaaten geltenden guten Ingenieurspraxis ausgelegt und werden dieser entsprechend hergestellt.

Niederspannungs-Richtlinie 2014/35/EU

Angewandte harmonisierte Normen:	EN 60204-1
----------------------------------	------------

EMV-Richtlinie 2014/30/EU

Angewandte harmonisierte Normen:	EN 61000-6-2:2005, EN 61000-6-4:2007+A1:2011
----------------------------------	--

ROHS II-Richtlinie 2011/65/EU

Die Vorschriften der Richtlinie 2011/65/EU zur Beschränkung der Verwendung bestimmter gefährlicher Stoffe in Elektro- und Elektronikgeräten werden erfüllt.

Der Hersteller trägt die alleinige Verantwortung für die Ausstellung dieser Konformitätserklärung.

Unterzeichnet für und im Namen von:

Neuss, 22.07.2016

BEKO TECHNOLOGIES GMBH

i.V. Christian Riedel

Leiter Qualitätsmanagement International

<p>Headquarter :</p> <p>Deutschland / Germany BEKO TECHNOLOGIES GMBH Im Taubental 7 D-41468 Neuss Tel. +49 2131 988 0 info@beko-technologies.de</p>	<p>中华人民共和国 / China BEKO TECHNOLOGIES (Shanghai) Co. Ltd. Rm. 606 Tomson Commercial Building 710 Dongfang Rd. Pudong Shanghai China P.C. 200122 Tel. +86 21 508 158 85 info@beko-technologies.cn</p>	<p>France BEKO TECHNOLOGIES S.a.r.l. Zone Industrielle 1 rue des Frères Rémy F- 57200 Sarreguemines Tel. +33 387 283 800 Info@beko-technologies.fr</p>
<p>India BEKO COMPRESSED AIR TECHNOLOGIES Pvt. Ltd. Plot No.43/1, CIEEP, Gandhi Nagar, Balanagar, Hyderabad 500 037, INDIA Tel. +91 40 23080275 eric.purushotham@bekoindia.com</p>	<p>Italia / Italy BEKO TECHNOLOGIES S.r.l Via Peano 86/88 I - 10040 Leini (TO) Tel. +39 011 4500 576 info.it@beko-technologies.com</p>	<p>日本 / Japan BEKO TECHNOLOGIES K.K KEIHIN THINK 8 Floor 1-1 Minamiwatarida-machi Kawasaki-ku, Kawasaki-shi JP-210-0855 Tel. +81 44 328 76 01 info@beko-technologies.jp</p>
<p>Benelux BEKO TECHNOLOGIES B.V. Veenen 12 NL - 4703 RB Roosendaal Tel. +31 165 320 300 benelux@beko-technologies.com</p>	<p>Polska / Poland BEKO TECHNOLOGIES Sp. z o.o. ul. Chłapowskiego 47 PL-02-787 Warszawa Tel. +48 22 855 30 95 info.pl@beko-technologies.pl</p>	<p>Scandinavia www.beko-technologies.de</p>
<p>España / Spain BEKO Tecnológica España S.L. Torruella i Urpina 37-42, nave 6 E-08758 Cervelló Tel. +34 93 632 76 68 info.es@beko-technologies.es</p>	<p>South East Asia BEKO TECHNOLOGIES S.E.Asia (Thailand) Ltd. 75/323 Romklao Road Sansab, Minburi Bangkok 10510 - Thailand Tel. +66 2-918-2477 info.th@beko-technologies.com</p>	<p>臺灣 / Taiwan BEKO TECHNOLOGIES Co.,Ltd 16F.-5, No.79, Sec. 1, Xintai 5th Rd., Xizhi Dist., New Taipei City 221, Taiwan (R.O.C.) Tel. +886 2 8698 3998 info@beko.com.tw</p>
<p>Česká Republika / Czech Republic BEKO TECHNOLOGIES s.r.o. Mlýnská 1392 CZ - 562 01 Usti nad Orlici Tel. +420 465 52 12 51 info.cz@beko-technologies.cz</p>	<p>United Kingdom BEKO TECHNOLOGIES LTD. 2 West Court Buntsford Park Road Bromsgrove GB-Worcestershire B60 3DX Tel. +44 1527 575 778 info@beko-technologies.co.uk</p>	<p>USA BEKO TECHNOLOGIES CORP. 900 Great SW Parkway US - Atlanta, GA 30336 Tel. +1 404 924-6900 beko@bekousa.com</p>

Original operating instructions in English.
Subject to technical changes / errors excepted.
DRYPOINT_RA_HT_5-100_manual_en_2019_04