

# Installation and operation manual

## Condensate drain

### **BEKOMAT® 3 E Ex PN63**

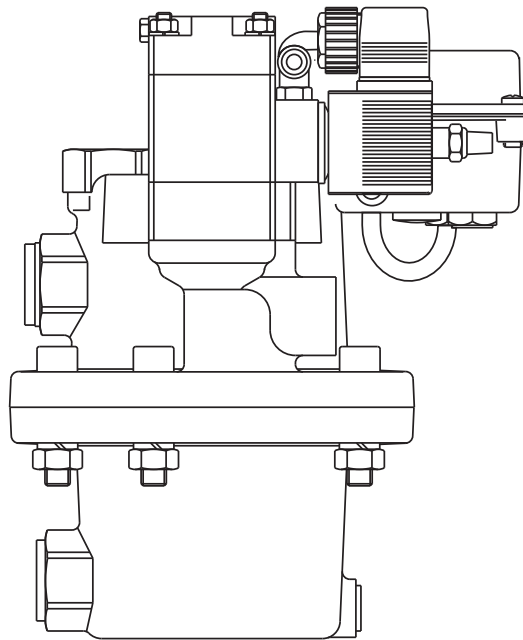

 II 2G Ex ib IIB T4 Gb  
BVS 03 ATEX E 214 X



## Inhalt

<b>1. Safety-related information</b> .....	<b>4</b>
1.1. Pictograms and symbols.....	4
1.1.1. In this documentation .....	4
1.1.2. On the device .....	4
1.2. Signal words.....	4
1.3. General safety instructions.....	5
1.4. Transport and storage .....	7
1.5. Intended use.....	8
<b>2. Product information</b> .....	<b>9</b>
2.1. Type plate .....	9
2.2. Product overview and description .....	10
2.3. Control and display elements.....	11
2.4. Function.....	12
2.5. Dimensions .....	13
2.6. Technical data .....	14
2.6.1. Marking of explosion-protected equipment in accordance with ATEX and EPL .....	15
<b>3. Installation</b> .....	<b>16</b>
3.1. Warning notices .....	16
3.2. Installation example .....	17
3.3. Installation steps .....	18
<b>4. Electrical installation</b> .....	<b>20</b>
4.1. Installation instructions .....	20
4.2. Connection diagram .....	21
4.3. Power supply .....	22
4.4. Potential equalisation .....	23
4.5. NAMUR interface .....	23
<b>5. Start-up procedure</b> .....	<b>23</b>
<b>6. Operation</b> .....	<b>24</b>
<b>7. Maintenance and servicing</b> .....	<b>25</b>
7.1. Maintenance schedule .....	25
7.2. Cleaning .....	25
7.3. Spare parts .....	26
7.4. Accessories .....	26
<b>8. Troubleshooting</b> .....	<b>27</b>
<b>9. Removal from service</b> .....	<b>27</b>
<b>10. Disassembly and disposal</b> .....	<b>27</b>

# 1. Safety-related information

## 1.1. Pictograms and symbols

### 1.1.1. In this documentation



General instructions



Adhere to the installation and operation manual



General hazard symbol (danger, warning, caution)



Beware of explosive substances / risk of explosion



General hazard symbol (danger, warning, caution) for mains voltage and system components carrying mains voltage

### 1.1.2. On the device



ATEX marking



Adhere to the installation and operation manual (on the type plate)

## 1.2. Signal words

**DANGER**

**Imminent hazard**

Consequences of non-compliance: serious or even fatal injury

**WARNING**

**Potential hazard**

Consequences of non-compliance: possibly serious or even fatal injury

**CAUTION**

**Imminent hazard**





Consequences of non-compliance: injury and/or damage to property

**NOTE**

**Additional notes, information, tips**

Consequences of non-compliance: Disturbances during operation and maintenance. No hazard to persons.

**1.3. General safety instructions**

<b>DANGER</b>	<b>Explosion</b>
	<p>Danger to life through explosion, deflagration or fire</p> <ul style="list-style-type: none"> <li>• In companies or company areas where there is a risk of explosion or fire, all the necessary protective measures must be taken for safe operation of the system parts and devices.</li> <li>• During all work, operation and maintenance observe the applicable regulations (e.g. ATEX, CENELEC, NEC, TRBS, national directives and regulations).</li> <li>• Sources of ignition must not be introduced into or have the potential to effect areas where there is a risk of explosion or fire.</li> <li>• If the handling of sources of ignition cannot be avoided for the time being, all the necessary measures to prevent a fire or explosion must be taken.</li> <li>• All connections such as condensate drain, control air connection and piston venting must be connected gas-tight to prevent the formation of potentially explosive atmospheres.</li> <li>• Make sure to only use tools approved for use in hazardous locations.</li> </ul>
<b>DANGER</b>	<b>Insufficient qualification</b>
 	<p>Inappropriate handling due to insufficient qualification can lead to explosions, serious property damage and personal injuries or death.</p> <ul style="list-style-type: none"> <li>• All the tasks described in this installation and operation manual may only be carried out by skilled technical personnel<sup>1</sup> with the qualifications described below.</li> <li>• The skilled technical personnel<sup>1</sup> must have read and understood the contents of the installation and operation manual before commencing any work.</li> </ul>
<b>DANGER</b>	<b>Escaping compressed gas</b>
	<p>Risk of serious or even fatal injury from suddenly released compressed gas, condensate or unsecured system components.</p> <ul style="list-style-type: none"> <li>• Before carrying out any assembly, installation or maintenance work, depressurise the system. These works may only be carried out by authorised skilled technical personnel<sup>1</sup>.</li> <li>• Use only pressure-resistant installation materials and suitable tools that are in proper working order.</li> <li>• Before pressure build-up, check all system parts and repair them, if necessary. Open valves slowly to prevent pressure blow outs in operating state.</li> <li>• Always prevent people or objects from being affected by condensate or escaping compressed gas.</li> <li>• Prevent vibrations, oscillations and impact from being transferred to system parts.</li> <li>• Perform a leakage test.</li> </ul>
<b>DANGER</b>	<b>Mains voltage</b>
	<p>Risk of electric shock with serious or fatal injuries if contact is made with non-insulated components carrying mains voltage.</p> <ul style="list-style-type: none"> <li>• Comply with all applicable regulations for electrical installations (e.g. VDE 0100 / IEC 60364).</li> <li>• Only execute installation and maintenance works when the system has been de-energised.</li> <li>• Electrical works may only be executed by authorised skilled technical personnel<sup>1</sup>.</li> </ul>

**<sup>1</sup> Skilled technical personnel**

Skilled technical personnel are people who, due to their professional qualification and knowledge in the field of measuring, control and pneumatic technology, and their knowledge of the country-specific regulations, applicable standards and directives are in a position to carry out the tasks described and foresee potential dangers independently. Special operating conditions e.g. aggressive media require additional knowledge. In addition, the requirements on “skilled technical personnel” set out in the Technical Rules for Operating Safety (TRBS) must be observed. It is the responsibility of the device/system owner to ensure that the instructions in this manual are adhered to.

<b>WARNING</b>	<b>Operation outside of limit values</b>
	<p>If limit values are exceeded or not reached, there is a risk to people and material, and malfunctions or operating faults may occur.</p> <ul style="list-style-type: none"> <li>• The device must only be operated for the intended purpose and within the permissible limits specified on the type plate and in the technical data.</li> <li>• Strictly adhere to the prescribed operating times and maintenance intervals.</li> </ul>

<b>NOTE</b>	<b>Installation and operation manual</b>
	<p>Before reading, check that this installation and operation manual matches the device type. It contains important information and notes on safe operation of the device. It is therefore essential that the installation and operation manual is read by the relevant specialist personnel<sup>1</sup> before starting any work.</p> <p>The manual must be easily accessible at the place of use of the device at all times.</p> <p>In addition to this installation and operation manual, the national and company legal and safety regulations as well as accident prevention regulations required for the respective application must also be observed. This also applies to the use of accessories and spare parts.</p>

**<sup>1</sup> Skilled technical personnel**

Skilled technical personnel are people who, due to their professional qualification and knowledge in the field of measuring, control and pneumatic technology, and their knowledge of the country-specific regulations, applicable standards and directives are in a position to carry out the tasks described and foresee potential dangers independently. Special operating conditions e.g. aggressive media require additional knowledge. In addition, the requirements on “skilled technical personnel” set out in the Technical Rules for Operating Safety (TRBS) must be observed. It is the responsibility of the device/system owner to ensure that the instructions in this manual are adhered to.

### 1.4. Transport and storage

Despite our best efforts, transport damage cannot be ruled out. For this reason, the device must be checked for possible transport damage after transport and removal of the packaging material. Any damage must be reported immediately to the transport company, BEKO TECHNOLOGIES GmbH or its representative.

<b>CAUTION</b>	<b>Damage caused during transport or storage</b>
	<p>Inappropriate transport or storage, or the use of unsuitable lifting equipment, might cause damage to the device.</p> <ul style="list-style-type: none"> <li>• The device may only be transported and stored by trained authorised and skilled personnel.</li> <li>• Do not operate the device if it is damaged.</li> <li>• Always adhere to the permissible storage and transport temperatures.</li> <li>• Never expose the device to continuous, direct sunlight or heat radiation.</li> </ul>

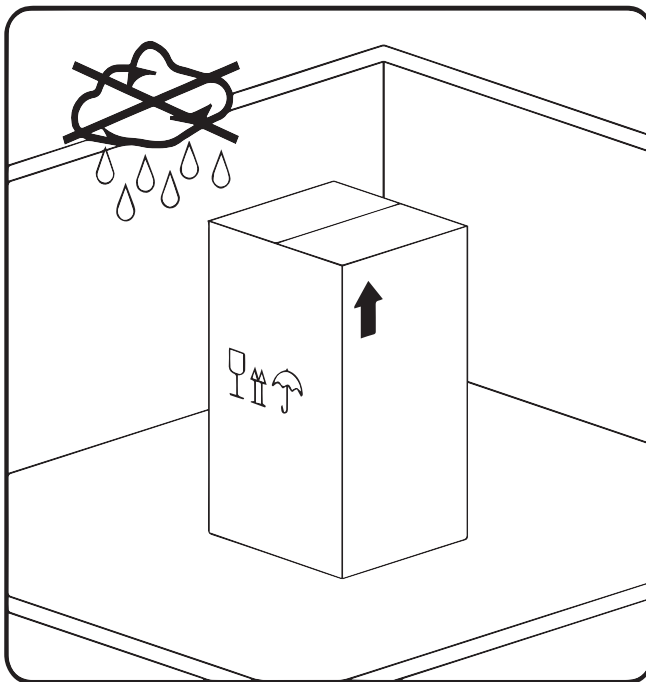

The device must be stored in its original packaging in a closed, dry and frost-free room. Ensure that the ambient conditions do not fall below or exceed the limits specified on the type plate.

Always take suitable measures to protect the device against the elements even in a packaged condition.

The device must be secured against falling over at the storage location and must be protected against falls and shocks.

<b>NOTE</b>	<b>Recycling packaging material</b>
	<ul style="list-style-type: none"> <li>• The packaging material is recyclable. The material must be disposed of in accordance with the guidelines and regulations of the country of destination.</li> </ul>

## 1.5. Intended use

The **BEKOMAT®** is an electronically level-controlled condensate drain for compressed air systems. It drains condensate from the system parts under operating pressure with virtually no loss of compressed air. The **BEKOMAT®** is also suitable for systems with low operating pressure, e.g. for multistage compressors, thanks to its design with no-load drain/no-load valve.

Only suitable for use with original spare parts and accessory parts.

The **BEKOMAT® 3 E Ex PN63** can be used in accordance with the following ATEX/EPL marking in areas with a potentially explosive atmosphere:

 **II 2G Ex ib IIB T4 Gb**

Permissible media are: **Ethane, methane, town gas (illumination gas), compressor oils, diesel fuel, ethylene, propane, heating oil, Group II fluids in accordance with PED**

For more information about the ATEX marking, see 2.6.1 on page 15.



The **BEKOMAT®** must not be used in areas subject to frost.

It may only be operated for the intended purpose and within the specifications stated in the technical data. Substances or gas/vapour mixtures not listed are not permitted. Any other use beyond this is considered improper and may jeopardise the safety of persons and the environment.

## 2. Product information

### 2.1. Type plate





The type plate is attached to the device housing. It lists all the important data for the **BEKOMAT®**. This must be communicated to the manufacturer or supplier on request.

BEKOMAT 3 E Ex No.: BVS 03 ATEX E 214 X ⊕ II 2G Ex ib IIB T4 Gb	+1...+60°C / 34...140°F 0,8-16 bar(g) / 12-230 psi(g) Ui = 12,6 / li = 150 mA	 	12345678 4004952 IP65
---	---	--	-----------------------------

  	BEKO TECHNOLOGIES GmbH Im Taubental 7 41468 Neuss Made in Germany	 12345678
---	--	---

#### Example illustration

Designation	Description
BEKOMAT 3 E Ex PN63	Type
1,2-63 bar(g) / 17-913 psi(g)	Operating pressure
+1...+60°C / 34...140°F	Operating temperature
12 VDC / <1,9 W	Operating voltage
4005093	Order reference
12345678	Serial number

	Kondensatableitersteuerung Condensate drain control Commande électronique au purgeur	
No.: BVS 03 ATEX E 214 X ⊕ II 2G Ex ib IIB T4 Gb Ui = 12.6 VDC / li = 150 mA	No. <input type="text"/> QM <input type="text"/>	
	Nur für bescheinigte, eigengesicherte Stromkreise. Only for certified, intrinsically safe circuits. Seulement pour des circuits de sécurité intrinsèque certifiés. BEKO TECHNOLOGIES GMBH Im Taubental 7, 41468 Neuss www.beko-technologies.com	

#### Example illustration

Designation	Description
No.: BVS 03 ATEX E 214 X	Type test certificate
 II 2G Ex ib IIB T4 Gb	Marking in accordance with ATEX and EPL
Ui = 12.6 VDC	Maximum input voltage
li = 150 mA	Maximum input current

<b>NOTE</b>	<b>Handling of type plate</b>
	Never damage, remove or make the type plate illegible.

## 2.2. Product overview and description

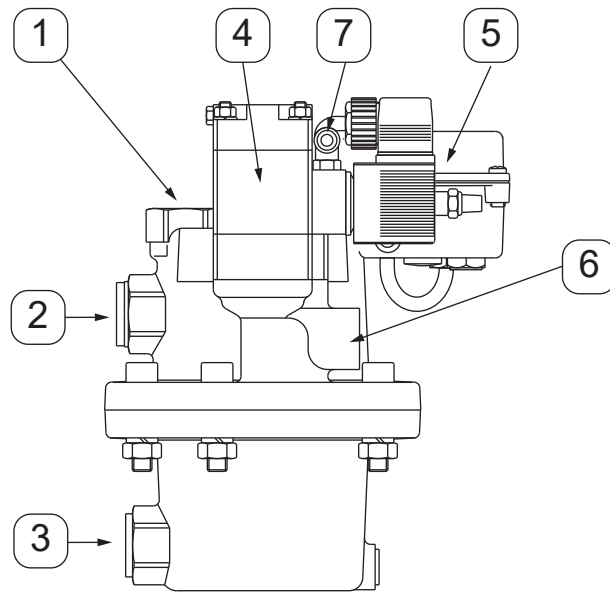

1 Top condensate inlet / venting line

2 Centre condensate inlet

3 Bottom condensate inlet

4 Solenoid valve

5 Electronics housing

6 Condensate drain solenoid valve

7 Control air connection

### 2.3. Control and display elements

The display and control elements of the **BEKOMAT®** are on the electronics housing.

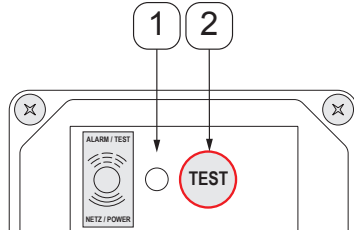

- 1 **Alarm / test LED**  
Indicates the current operating state of the **BEKOMAT®**.
- 2 **Test button**  
Is used for depressurising or manually drain the **BEKOMAT®**.

<b>NOTE</b>	<b>No permanent draining</b>
	Do not use the test button for permanent draining.

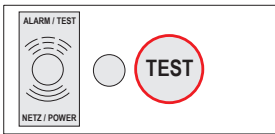

**Alarm / test LED is off**  
The **BEKOMAT®** is without function and there is no voltage applied.

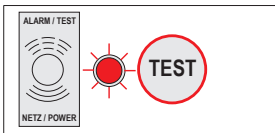

**Alarm / test LED is lit**  
The **BEKOMAT®** is being supplied with voltage and operates in normal mode.

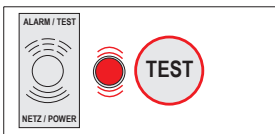

**Alarm / test LED is flashing**  
The **BEKOMAT®** is in alarm mode or the test button is being pressed.

**Alarm mode:**

The **BEKOMAT®** is monitored by its electronics and sensors. If a fault is detected during operation, the **BEKOMAT®** changes to alarm mode. This can be caused by a blocked condensate drain line or overload. In alarm mode the solenoid valve opens cyclically to eliminate the malfunction independently. If the fault is still present after one minute, the red alarm LED flashes and the optocoupler outlet switches. From now on, the valve opens every four minutes for 7.5 seconds until the malfunction has been eliminated independently or through maintenance. Once the fault has been rectified, the **BEKOMAT®** automatically returns to normal operation.

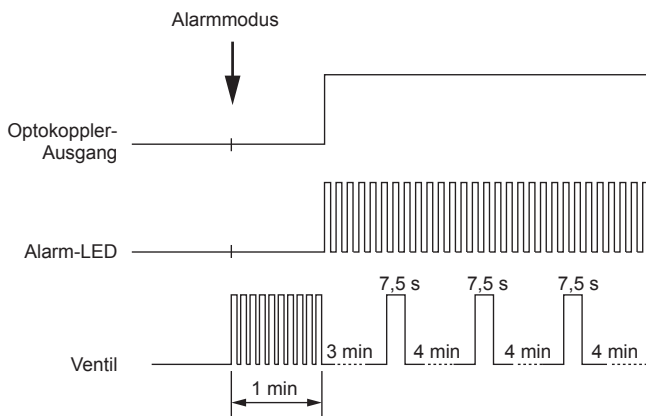

<b>NOTE</b>	<b>Additional information</b>
	For more information about how the <b>BEKOMAT®</b> works, see function 2.4 on page 12.

### 2.4. Function

Condensate drips through the inlet opening [B] and collects in the container [A]. The valve core [7] of the solenoid valve [9] closes the control air supply [E]. The piston valve [2] is closed, since the springs [4] and [5] press it onto the valve seat [D] and close the venting line [F]. Thus the membrane [10] is pressed onto the membrane seat [H], since the larger effective area is at the top and the operating pressure below and above the membrane is the same. The membrane seat remains closed leak-free.

If the capacitive level sensor [1] registers condensate, the solenoid valve is switched over by a signal. The control air supply [E, 6] is then opened to the piston valve. The control air (gas) pressure causes the piston to lift [2]. This opens the venting line [F] and the pressure above the membrane is reduced since air (gas) can only flow in throttled through the nozzle [C]. The valve membrane [10] lifts off the membrane seat [H] when the space above the membrane is depressurised, and the excess pressure in the housing forces the condensate into the drain line [G]. The BEKOMAT® electronics are programmed in such a way that the valve is closed leak-free before compressed air or gas can escape. The outlet sluice [I] ensures that any coarse dirt is kept back at the bottom of the container. If the condensate discharge is malfunctioning (blocked drain line), the membrane is faulty, the minimum pressure in the piping system falls below 1.2 bar, there is no control compressed air or the operating pressure of the control air is too low, the BEKOMAT® goes into alarm mode after 60 seconds. A device filled in a depressurised state is emptied again automatically as soon as a minimum pressure of 1.2 bar is reached in the BEKOMAT® and the control pressure is available. The alarm message can be forwarded via the opto-coupler output. Gas loss due to valve soiling, wear and other malfunctions cannot be excluded.

Valve closed

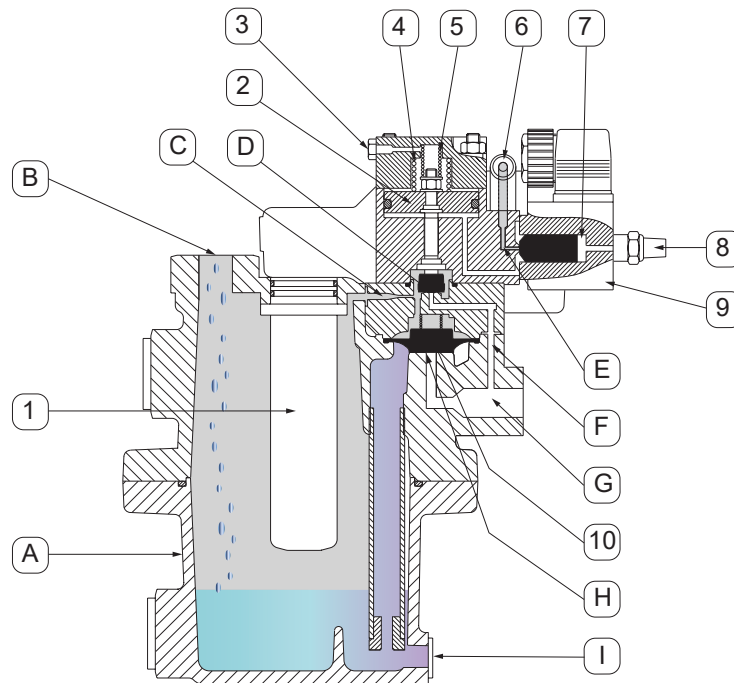

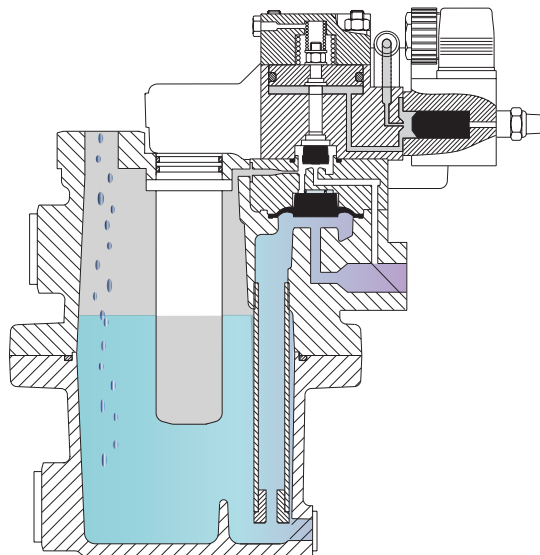

Valve open

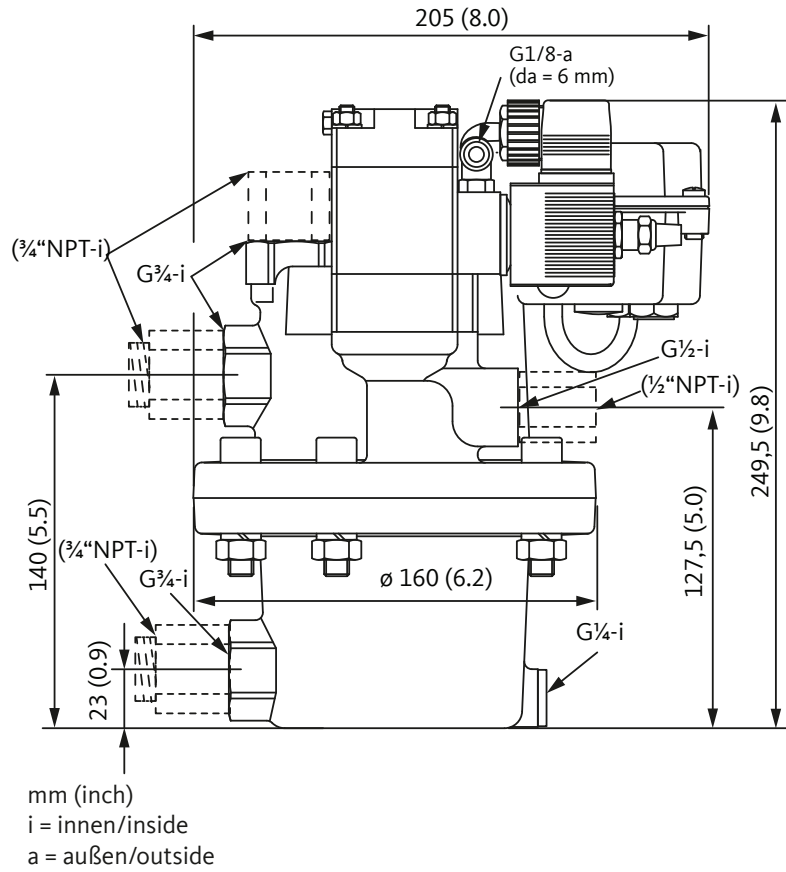

### 2.5. Dimensions



2.6. Technical data

 II 2G Ex ib IIB T4 Gb  <b>0158 IP 65</b>	
<b>General data</b>	
<b>BEKOMAT 3 E Ex PN63</b>	
Device group	II
Device category	2G
Type of protection	ib
Explosion group	IIB
Temperature class	T4
Device protection level	Gb
Min./max. storage/transport temperature	+1 ... +60 °C
Min./max. ambient temperature	+1 ... +60 °C
Min./max. media temperature	+1 ... +60 °C
Condensate inlet (optional: NPT thread)	3 x G <sup>3</sup> / <sub>4</sub> , female
Condensate drain (optional: NPT thread)	1 x G <sup>1</sup> / <sub>2</sub> , female
Control air connection	Hose connection da = 6 mm
Condensate	Oil-contaminated condensate   oil-free, often aggressive condensate
Weight	5.8 kg (empty)
Materials	Housing: Stainless steel Membrane: FKM
<b>Performance data</b>	
<b>BEKOMAT 3 E Ex PN63</b>	
Max. discharge rate (short-term)	700 l/h
Ø - discharge rate	43 l/h
Min./max operating overpressure	1.2 ... 63 bar
Min./max. control air pressure	4 ... 8 bar
<b>Electrical data</b>	
<b>BEKOMAT 3 E Ex PN63</b>	
Operating voltage (connection to intrinsically safe voltage supply with the following data)	V <sub>nom</sub> = 12.0 V / V <sub>i</sub> = 12.6 V I <sub>i</sub> = 150 mA / P <sub>i</sub> = 1.9 W L <sub>i</sub> = Negligible C <sub>i</sub> = 3,6 µF
Power consumption	P ≤ 1.9 W
Cable diameter, round	8 ... 11 mm
Cable diameter, shielded / metal-jacketed	8 ... 11 mm
Wire cross-sectional area	3 x 0.75 ... 1.5 mm <sup>2</sup> (AWG 16 ... 20)
Degree of protection	IP 65
Valve circuit	U <sub>o</sub> = 12,6 V (max.) I <sub>o</sub> = 150 mA (max.) / P <sub>o</sub> = 1,9 W (max.)
Alarm output	Opto-coupler output for the operation of a NAMUR interface in accordance with DIN EN 60947-5-6 U <sub>i</sub> = 13.5 V (max.) / I <sub>i</sub> = 62 mA (max.) / P <sub>i</sub> = 125 mW (max.) C <sub>i</sub> negligible / L <sub>i</sub> negligible
Solenoid valve	EN IEC 60079-0:2018 EN 60079-11:2012  II2G Ex ia IIC T6/T4 Gb EPS 18 ATEX 1088X PX55





### 2.6.1. Marking of explosion-protected equipment in accordance with ATEX and EPL

<b>II</b>	<b>Device group II</b> Suitable for use in industrial potentially explosive areas, <b>not</b> in mines
<b>2G</b>	<b>Device category 2G</b> Suitable for areas where an explosive atmosphere consisting of gases, vapours, mists or air mixtures is likely to occur occasionally, rarely or for a short period only (zones 1 and 2).
<b>Ex ib</b>	<b>Type of protection ib - intrinsically safe</b> Intrinsically safe in accordance with EN 60079-11
<b>IIB</b>	<b>Explosion group IIB</b> Suitable for gases and vapours with a maximum experimental safe gap of 0.5 ... 0.9 mm and a minimum feed ratio of 0.45 - 0.8.*
<b>T4</b>	<b>Temperature class T4 (&lt;135 °C)</b> Suitable for gases and vapours with an ignition temperature of from > 135 to ≤ 200°
<b>Gb</b>	<b>Device protection level Gb</b> Suitable for areas where an explosive atmosphere consisting of gases, vapours, mists or air mixtures is likely to occur occasionally, rarely or for a short period only. (Zone 1 and 2)

\*related to methane = 1

### 3. Installation

#### 3.1. Warning notices

<b>DANGER</b>	<b>Explosion</b>
	<p>Danger to life through explosion, deflagration or fire</p> <ul style="list-style-type: none"> <li>• During all work, operation and maintenance observe all the applicable regulations (e.g. ATEX, CENELEC, NEC, TRBS, national directives and regulations).</li> <li>• Take all the protective measures for potentially explosive areas. Normal operation may only be started after the effectiveness of the necessary explosion protection measures has been ensured.</li> <li>• Make sure to only use tools approved for use in hazardous locations.</li> </ul>
<b>DANGER</b>	<b>Insufficient qualification, explosion</b>
 	<p>Inappropriate handling due to insufficient qualification can lead to explosions, serious property damage and personal injuries or death.</p> <ul style="list-style-type: none"> <li>• All the tasks described in this installation and operation manual may only be carried out by skilled technical personnel<sup>1</sup> with the qualifications described below.</li> <li>• The skilled technical personnel<sup>1</sup> must have read and understood the contents of the installation and operation manual before commencing any work.</li> </ul>
<b>DANGER</b>	<b>Escaping compressed gas</b>
	<p>There is a risk of serious injury or death due to incorrect assembly or unsecured system parts.</p> <ul style="list-style-type: none"> <li>• Only carry out installation work when the system is depressurised.</li> <li>• Use only pressure-resistant installation materials and suitable tools that are in proper working order.</li> <li>• Before pressure build-up, check all system parts and repair them, if necessary. Open valves slowly to prevent pressure blow outs in operating state.</li> <li>• Always prevent people or objects from being affected by condensate or escaping compressed gas.</li> <li>• Prevent vibrations, oscillations and impact from being transferred to system parts.</li> <li>• Perform a leakage test.</li> </ul>

#### <sup>1</sup> Skilled technical personnel

Skilled technical personnel are people who, due to their professional qualification and knowledge in the field of measuring, control and pneumatic technology, and their knowledge of the country-specific regulations, applicable standards and directives are in a position to carry out the tasks described and foresee potential dangers independently. Special operating conditions e.g. aggressive media require additional knowledge. In addition, the requirements on “skilled technical personnel” set out in the Technical Rules for Operating Safety (TRBS) must be observed. It is the responsibility of the device/system owner to ensure that the instructions in this manual are adhered to.

### 3.2. Installation example

The following illustration shows possible assembly of the **BEKOMAT®** in a potentially explosive area [1].

DANGER	Explosion
	<p>Danger to life through explosion, deflagration or fire</p> <ul style="list-style-type: none"> <li>• During all work, operation and maintenance observe all the applicable regulations (e.g. ATEX, CENELEC, NEC, TRBS, national directives and regulations).</li> <li>• The following illustration is only one possible assembly example and can deviate from the circumstances on site. It does not replace the operating company's obligation to define zones and to check the effectiveness of the avoidance of explosions following the installation work.</li> </ul>

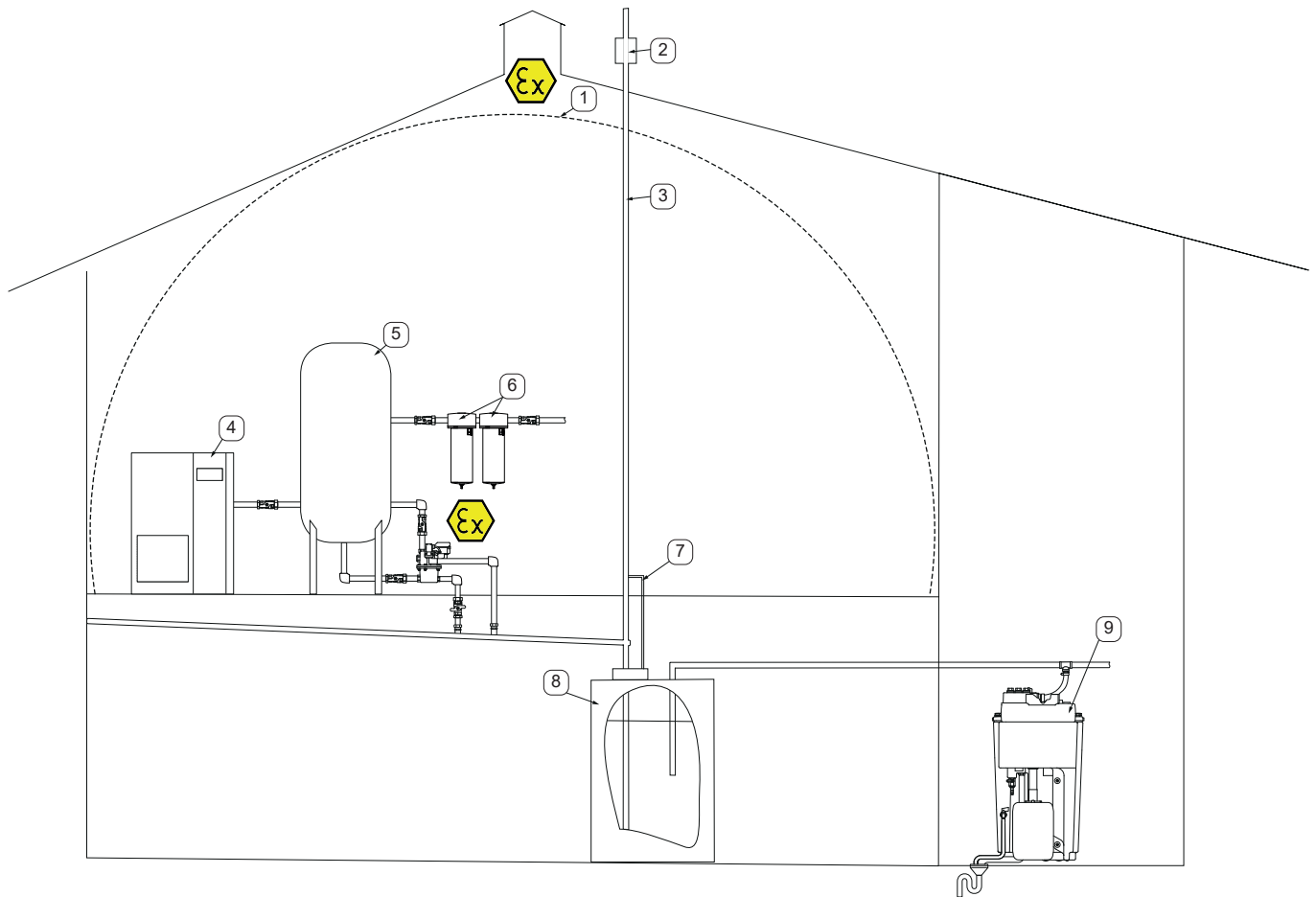

- |                               |   |
|-------------------------------|---|
| ① Explosive atmosphere (zone) | ⑥ Filter                                      |
| ② Flashback preventer         | ⑦ Residual degassing line                     |
| ③ Degassing line              | ⑧ Degassing vessel                            |
| ④ Compressor                  | ⑨ Condensate processing (oil/water separator) |
| ⑤ Compressed air vessel       |   |

### 3.3. Installation steps

The following illustrations show possible installation of the **BEKOMAT®** depending on the amount of condensate.

NOTE	Installation instructions
	<ul style="list-style-type: none"> <li>• Install a separate <b>BEKOMAT®</b> at each condensate collection point.</li> <li>• Do not use conical screw connections.</li> <li>• Keep pipe length as short as possible.</li> <li>• Do not fit a filter/dirt trap into the condensate inlet.</li> <li>• Only use ball valves for the condensate inlet.</li> <li>• The venting line must be above the max. possible condensate level.</li> <li>• Observe minimum installation heights</li> </ul>

DANGER	Explosion
	<p>Danger to life through explosion, deflagration or fire</p> <ul style="list-style-type: none"> <li>• In companies or company areas where there is a risk of explosion or fire, all the necessary protective measures must be taken for safe operation of the system parts and devices.</li> <li>• During all work, operation and maintenance observe the applicable regulations (e.g. ATEX, CENELEC, NEC, TRBS, national directives and regulations).</li> <li>• Sources of ignition must not be introduced into or have the potential to effect areas where there is a risk of explosion or fire.</li> <li>• If the handling of sources of ignition cannot be avoided for the time being, all the necessary measures to prevent a fire or explosion must be taken.</li> <li>• All connections such as condensate drain, control air connection and piston venting must be connected gas-tight to prevent the formation of potentially explosive atmospheres.</li> </ul>

**Control air connection**

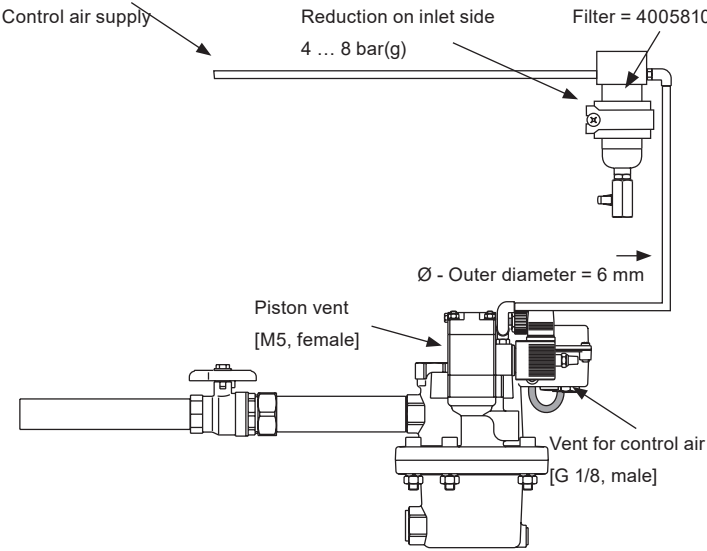

Control air supply

Reduction on inlet side  
4 ... 8 bar(g)

Filter = 4005810

Ø - Outer diameter = 6 mm

Piston vent  
[M5, female]

Vent for control air  
[G 1/8, male]

When using the **BEKOMAT®** there is no guarantee against gas outbreak. A small quantity of the gas/air mixture can occasionally escape with the discharged condensate. Care must be taken that no potentially explosive atmospheres can form during control air discharge.

In addition, the vents on the piston and the venting for control air can be equipped with a hose connection to discharge any flammable gas mixtures.

To operate the **BEKOMAT®**, pressurised control air or gas with an operating pressure of 4 ... 8 bar(g) is required. When operating the HP valve with explosive pilot gas, it is essential to ensure that this pilot gas is not released into the environment after the switching process has been completed. In this case, the control gas must be routed into the degassing vessel or the condensate drain line.

**BEKOMAT® 3 E Ex PN63 - condensate accumulation < 360 l/h**

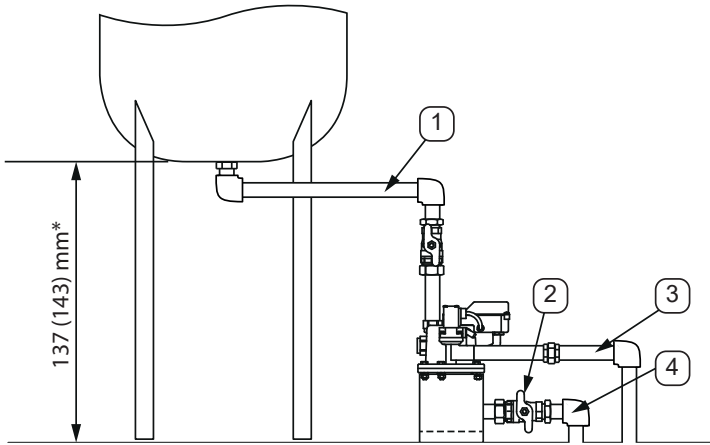

- ① **Top condensate inlet ( $\varnothing \geq \frac{3}{4}$ "**  
Install pipes fixed and route with continuous slope ( $\geq 1^\circ$ )
- ② **Manual condensate drain ( $\varnothing \geq \frac{1}{4}$ "**  
**recommended**  
Install pipes fixed and route with continuous slope ( $\geq 1^\circ$ )
- ③ **Condensate drain solenoid valve ( $\varnothing \geq \frac{1}{2}$ "**  
Install pipes fixed and route with continuous slope ( $\geq 1^\circ$ )
- ④ **Manual condensate drain ( $\varnothing \geq \frac{1}{4}$ "**  
Install pipes fixed and route with continuous slope ( $\geq 1^\circ$ )

**i** Assembly with floor bracket is recommended.

**BEKOMAT® 3 E Ex PN63 - condensate accumulation > 360 l/h**

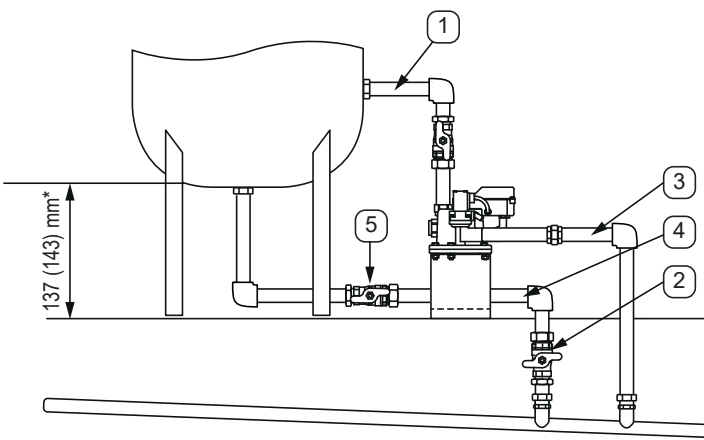





\*Mindesteinbauhöhe (mit Bodenhalter)

- ① **Venting line ( $\varnothing \geq \frac{3}{4}$ "**  
Install pipes fixed
- ② **Manual condensate drain ( $\varnothing \geq \frac{1}{4}$ "**  
**recommended**  
Install pipes fixed
- ③ **Condensate drain solenoid valve ( $\varnothing \geq \frac{1}{2}$ "**  
Install pipes fixed and route with continuous slope ( $\geq 1^\circ$ )
- ④ **Manual condensate drain ( $\varnothing \geq \frac{1}{4}$ "**  
Install pipes fixed and route with continuous slope ( $\geq 1^\circ$ )
- ⑤ **Bottom condensate inlet ( $\varnothing \geq \frac{3}{4}$ "**  
Install pipes fixed and route with continuous slope ( $\geq 1^\circ$ )

**i** Assembly with floor bracket is recommended.

## 4. Electrical installation

### 4.1. Installation instructions

<b>DANGER</b>	<b>Insufficient qualification</b>
 	<p>Inappropriate handling due to insufficient qualification can lead to explosions, serious property damage and personal injuries or death.</p> <ul style="list-style-type: none"> <li>• All the tasks described in this installation and operation manual may only be carried out by skilled technical personnel<sup>1</sup> with the qualifications described below.</li> <li>• The skilled technical personnel<sup>1</sup> must have read and understood the contents of the installation and operation manual before commencing any work.</li> </ul>
<b>DANGER</b>	<b>Explosion</b>
	<p>Danger to life through explosion, deflagration or fire</p> <ul style="list-style-type: none"> <li>• During all work, operation and maintenance observe all the applicable regulations (e.g. ATEX, CENELEC, NEC, TRBS, national directives and regulations).</li> <li>• Take all the protective measures for potentially explosive areas. Normal operation may only be started after the effectiveness of the necessary explosion protection measures has been ensured.</li> <li>• Make sure to only use tools approved for use in hazardous locations.</li> <li>• Make sure to only use cables rated for the location of use.</li> <li>• Connect the cables with appropriate strain relief elements.</li> <li>• Observe the maximum thermal loads for the inserted cables.</li> </ul>
<b>DANGER</b>	<b>Mains voltage</b>
	<p>Risk of electric shock with serious or fatal injuries if contact is made with non-insulated components carrying mains voltage.</p> <ul style="list-style-type: none"> <li>• Comply with all applicable regulations for electrical installations (e.g. VDE 0100 / IEC 60364).</li> <li>• Only execute installation and maintenance works when the system has been de-energised.</li> <li>• Electrical works may only be executed by authorised skilled technical personnel<sup>1</sup>.</li> </ul>

#### <sup>1</sup> Skilled technical personnel

Skilled technical personnel are people who, due to their professional qualification and knowledge in the field of measuring, control and pneumatic technology, and their knowledge of the country-specific regulations, applicable standards and directives are in a position to carry out the tasks described and foresee potential dangers independently. Special operating conditions e.g. aggressive media require additional knowledge. In addition, the requirements on “skilled technical personnel” set out in the Technical Rules for Operating Safety (TRBS) must be observed. It is the responsibility of the device/system owner to ensure that the instructions in this manual are adhered to.

4.2. Connection diagram

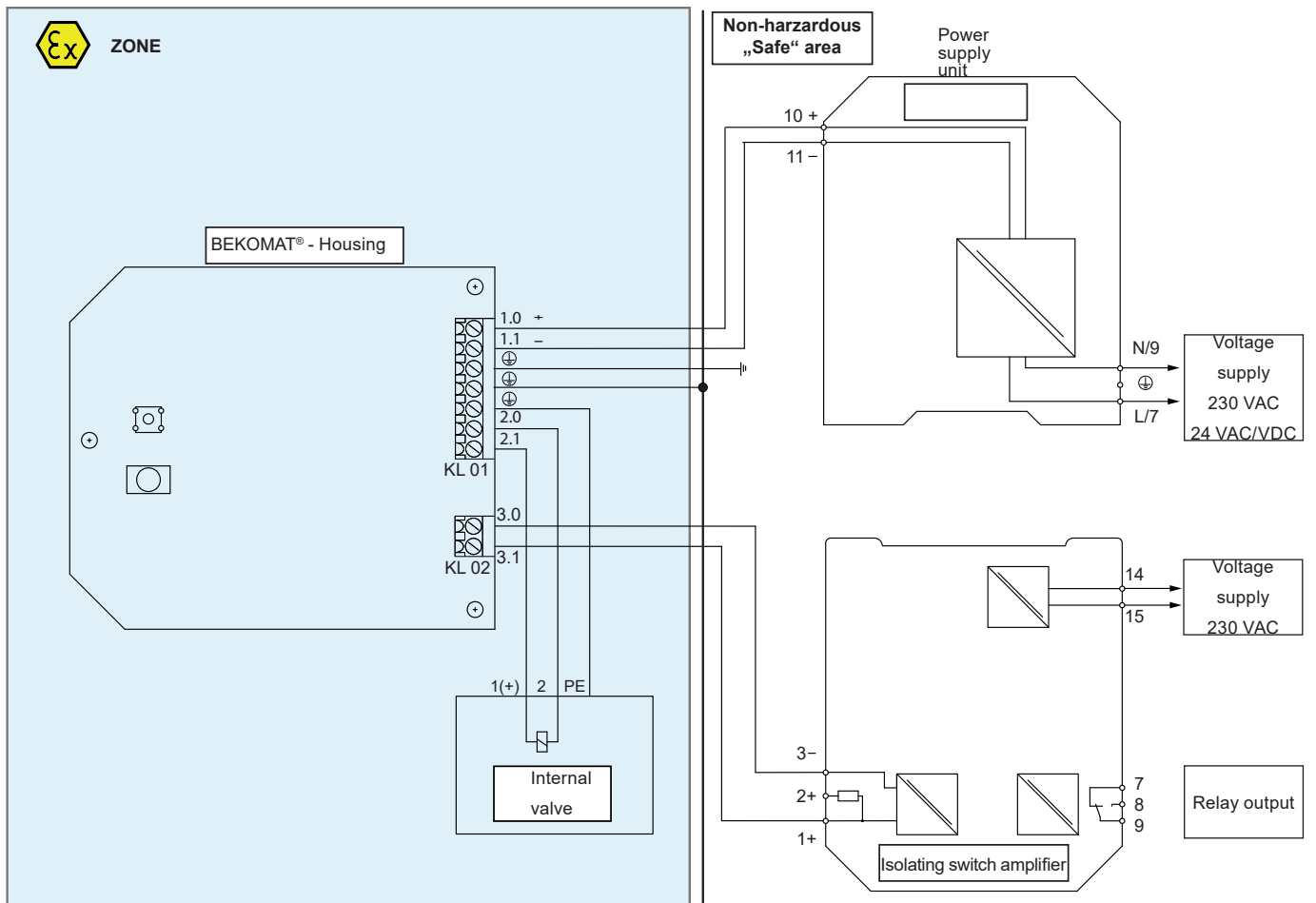

### 4.3. Power supply

Connection of the voltage supply must be carried out in compliance with the connection diagram and using an intrinsically safe power supply unit.

NOTE	Information on intrinsically safe power supply unit
	For more information on the intrinsically safe power supply unit see accessories 7.4 on page 26. For more information about the power supply of the intrinsically safe voltage supply see the separate installation and operation manual.

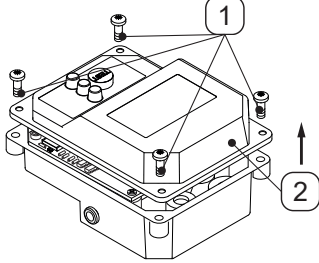
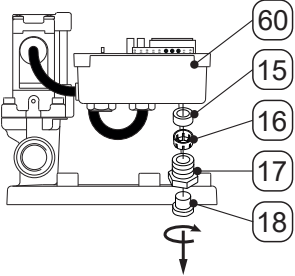
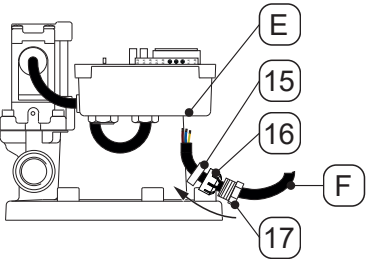
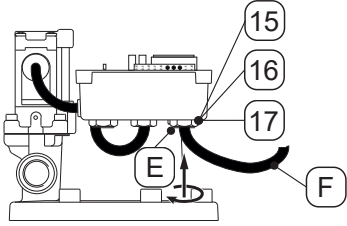
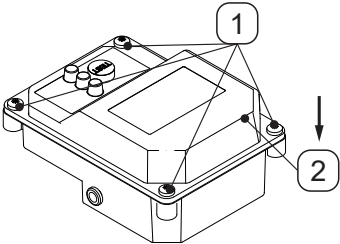
	<ol style="list-style-type: none"> <li>Loosen the 4 screws [1] of the top cover [2] and lift the top cover [2] off.</li> </ol>
	<ol style="list-style-type: none"> <li>Unscrew the components [15, 16, 17, 18] of the right cable gland [E] out.</li> </ol>
	<ol style="list-style-type: none"> <li>Slide the pressure screw [17] with the thread facing the end of the cable onto the voltage supply cable [F].</li> <li>Slide the claw [16], with the teeth pointing in the direction of the sealing nut [17], onto the power supply cable [F].</li> <li>Slide the sealing ring [15] onto the voltage supply cable [F].</li> <li>Insert the voltage supply cable [F] into the right cable gland [E].</li> <li>Connect the voltage supply cable [F] as indicated on the connection diagram "4.2. Connection diagram" on Page 21.</li> </ol>
	<ol style="list-style-type: none"> <li>Tighten the voltage supply cable [F] and screw the components of the cable gland [15, 16, 17] into the right cable gland [E].</li> <li>Tighten the pressure screw [17] with a torque of 2 Nm.</li> </ol>
	<ol style="list-style-type: none"> <li>Set the top cover [2] in place and fasten using the 4 screws [1].</li> </ol>

#### 4.4. Potential equalisation

The **BEKOMAT**<sup>®</sup> is potential equalised via the earthing terminals provided. It must be ensured that these are integrated in the potential equalisation.

Install the potential equalisation in compliance with the connection diagram 4.2 on page 21.

#### 4.5. NAMUR interface

The **BEKOMAT**<sup>®</sup> has a NAMUR interface for forwarding fault messages so that faults can be recognised in good time during operation. It is recommended that the NAMUR interface be processed via an isolating switch amplifier and forwarded to a central control centre.

Install the NAMUR interface in compliance with the connection diagram 4.2 on page 21.

NOTE	Information about the NAMUR interface
	For more information about the power supply to the NAMUR interface see the separate installation and operation manual.

### 5. Start-up procedure

Once assembly and the electrical installation work has been completed, the **BEKOMAT**<sup>®</sup> can be put into operation.

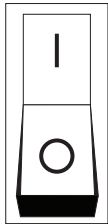
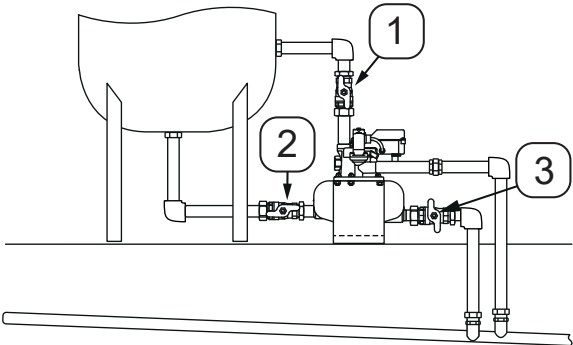
	<ol style="list-style-type: none"> <li>1. Supply the <b>BEKOMAT</b><sup>®</sup> with voltage</li> </ol>
	<ol style="list-style-type: none"> <li>2. Close the manual condensate drain [3]</li> <li>3. Slowly open the valves of the condensate inlet [1], [2] and pressurise the <b>BEKOMAT</b><sup>®</sup>.</li> </ol>

## 6. Operation



The **BEKOMAT**<sup>®</sup> has a NAMUR interface to detect faults during operation. It is recommended to process these at a central control centre in order to be informed of faults in good time.

<b>NOTE</b>	<b>Information about the NAMUR interface</b>
	For more information about the power supply to the NAMUR interface see the separate installation and operation manual and the NAMUR interface 4.5 on page 23.

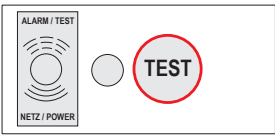
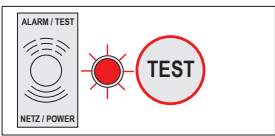
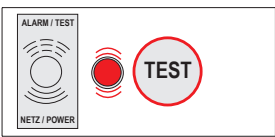
The following displays show the different operating states of the **BEKOMAT**<sup>®</sup>.

	<p><b>Alarm / test LED is off</b> The <b>BEKOMAT</b><sup>®</sup> is without function and there is no voltage applied.</p>
	<p><b>Alarm / test LED is lit</b> The <b>BEKOMAT</b><sup>®</sup> is being supplied with voltage and operates in normal mode.</p>
	<p><b>Alarm / test LED is flashing</b> The <b>BEKOMAT</b><sup>®</sup> is in alarm mode or the test button is being pressed.</p>

## 7. Maintenance and servicing

<b>DANGER</b>	<b>Insufficient qualification</b>
 	Inappropriate handling due to insufficient qualification can lead to explosions, serious property damage and personal injuries or death.
	<ul style="list-style-type: none"> <li>Maintenance work may only be carried out by trained service personnel from BEKO TECHNOLOGIES GmbH or authorised partners.</li> </ul>

### 7.1. Maintenance schedule

Maintenance	Interval
<b>Functional test</b> <ul style="list-style-type: none"> <li>Press the TEST button</li> <li>Visual inspection</li> </ul>	daily
<b>Maintenance</b> <ul style="list-style-type: none"> <li>Replace the set of wear parts</li> <li>Leakage test</li> <li>Functional test</li> <li>Check adhesive labels and replace if necessary</li> <li>Check length of valve core</li> <li>Check cable connections</li> <li>Check Namur interface</li> <li>Cleaning</li> </ul>	annually

**Functional test:**

The **BEKOMAT**® should be checked daily to ensure that it is working properly.

- To check the solenoid valve, briefly press the test button (approx. 2 seconds).  
→ The **BEKOMAT**® starts manual drainage.
- To check the NAMUR interface, shut off the condensate inlet and press the test button for approx. 1 minute.  
→ The **BEKOMAT**® starts manual drainage and triggers the alarm.

**i** During this test, larger quantities of compressed gas can flow into the condensate collection line.

**Maintenance:**

Further information about maintenance will be provided on request.

### 7.2. Cleaning

The **BEKOMAT**® is cleaned with a damp (not wet) cotton or disposable cloth and a mild, commercially available cleaning agent/soap.

To clean, spray the cleaning agent onto an unused cotton or disposable cloth and rub the component over the entire surface. Then dry using a clean cloth or let it dry at room temperature. Observe all hygiene instructions applicable on the site.

<b>NOTE</b>	<b>Damage to device caused by improper cleaning</b>
	Cleaning with a wet cloth, hard or pointed implement or aggressive detergent can damage the components and integrated electronic components.
	<ul style="list-style-type: none"> <li>Never clean the device with a dripping wet cloth.</li> <li>Do not use aggressive detergents.</li> <li>Never clean the device with hard or pointed implements.</li> </ul>

### 7.3. Spare parts

	Top cover	2800768
---	-----------	---------

### 7.4. Accessories

The table below indicates possible accessories.

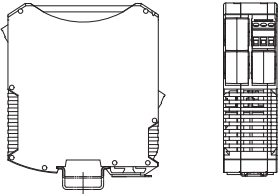
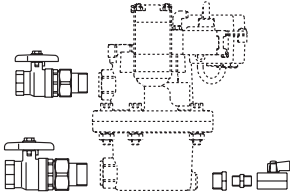
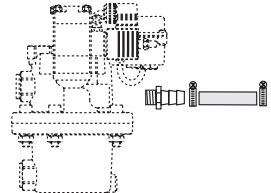
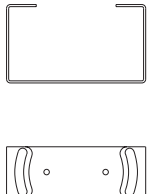
Illustration	Description	Order number*
	Ex-power supply unit	4005140 → Voltage: 85 ... 230 VAC 4010890 → Voltage: 24 VAC/VDC
	Connection set	2000043
	Drain kit	2000046
	Floor bracket	2801260 → Material: Steel 2801263 → Material: Stainless steel

\* Always state the serial number of the **BEKOMAT**® with every spare parts order

### 8. Troubleshooting

If malfunctions cannot be rectified, the device should be sent to us for repair. The device must be carefully cleaned and packed in a break-proof way before shipping. A return dispatch declaration with detailed description of the malfunction must be enclosed with the faulty device. If your device has come into contact with pollutants, a decontamination declaration is also required. You will find corresponding templates on our website at [www.beko-technologies.com](http://www.beko-technologies.com). If you should return your device without a decontamination declaration and our Service department has doubts about the medium used, repairs will only be started once a respective declaration has been received. If the device has come into contact with pollutants, appropriate precautionary measures must be taken during cleaning!

### 9. Removal from service

The device can be put out of operation as follows:

	<ol style="list-style-type: none"> <li>1. Close the bottom condensate inlet [2].</li> <li>2. Press the test button [4] for manual drainage.</li> <li>3. Close the top condensate inlet [1].</li> <li>4. Open the manual condensate drain [3].</li> </ol>
	<ol style="list-style-type: none"> <li>5. <b>Disconnect the BEKOMAT®</b> from the voltage supply</li> </ol>

### 10. Disassembly and disposal

This device must be disposed of in compliance with the European Directive 2012/19/EU. Used devices must not be disposed of with household waste!

If the device has come into contact with harmful substances, this must be given special consideration when disposing of it!

**BEKO TECHNOLOGIES GmbH**

Im Taubental 7  
 D - 41468 Neuss  
 Tel. +49 2131 988 0  
 Fax +49 2131 988 900  
 info@beko-technologies.com  
 service-eu@beko-technologies.com

**DE****BEKO TECHNOLOGIES LTD.**

Unit 11-12 Moons Park  
 Burnt Meadow Road  
 North Moons Moat  
 Redditch, Worcs, B98 9PA  
 Tel. +44 1527 575 778  
 info@beko-technologies.co.uk

**GB****BEKO TECHNOLOGIES S.à.r.l.**

Zone Industrielle  
 1 Rue des Frères Rémy  
 F - 57200 Sarreguemines  
 Tél. +33 387 283 800  
 info@beko-technologies.fr  
 service@beko-technologies.fr

**FR****BEKO TECHNOLOGIES B.V.**

Veenen 12  
 NL - 4703 RB Roosendaal  
 Tel. +31 165 320 300  
 benelux@beko-technologies.com  
 service-bnl@beko-technologies.com

**NL****BEKO TECHNOLOGIES  
(Shanghai) Co. Ltd.**

Rm.715 Building C, VANTONE Center  
 No.333 Suhong Rd.Minhang District  
 201106 Shanghai  
 Tel. +86 (21) 50815885  
 info.cn@beko-technologies.cn  
 service1@beko.cn

**CN****BEKO TECHNOLOGIES s.r.o.**

Na Pankráci 26/322  
 CZ - 140 00 Praha 4  
 Tel. +420 24 14 14 717 /  
 +420 24 14 09 333  
 info@beko-technologies.cz

**CZ****BEKO Tecnológica España S.L.**

Torruella i Urpina 37-42, nave 6  
 E - 08758 Cervelló  
 Tel. +34 93 632 76 68  
 Mobil +34 610 780 639  
 info.es@beko-technologies.es

**ES****BEKO TECHNOLOGIES LIMITED**

Room 2608B, Skyline Tower,  
 No. 39 Wang Kwong Road  
 Kwloon Bay Kwloon, Hong Kong  
 Tel. +852 2321 0192  
 Raymond.Low@beko-technologies.com

**HK****BEKO TECHNOLOGIES INDIA Pvt. Ltd.**

Plot No.43/1 CIEEP Gandhi Nagar  
 Balanagar Hyderabad  
 IN - 500 037  
 Tel. +91 40 23080275 /  
 +91 40 23081107  
 Madhusudan.Masur@bekoindia.com  
 service@bekoindia.com

**IN****BEKO TECHNOLOGIES S.r.l**

Via Peano 86/88  
 I - 10040 Leinì (TO)  
 Tel. +39 011 4500 576  
 Fax +39 0114 500 578  
 info.it@beko-technologies.com  
 service.it@beko-technologies.com

**IT****BEKO TECHNOLOGIES K.K**

KEIHIN THINK Building 8 Floor  
 1-1 Minamiwatarida-machi  
 Kawasaki-ku, Kawasaki-shi  
 JP - 210-0855  
 Tel. +81 44 328 76 01  
 info@beko-technologies.jp

**JP****BEKO TECHNOLOGIES Sp. z o.o.**

ul. Pańska 73  
 PL - 00-834 Warszawa  
 Tel. +48 22 314 75 40  
 info.pl@beko-technologies.pl

**PL****BEKO TECHNOLOGIES S. de R.L. de C.**

BEKO Technologies, S de R.L. de C.V.  
 Blvd. Vito Alessio Robles 4602 Bodega 10  
 Zona Industrial  
 Saltillo, Coahuila, 25107  
 Mexico  
 Tel. +52(844) 218-1979  
 informacion@beko-technologies.com

**MX****BEKO TECHNOLOGIES, CORP.**

900 Great Southwest Pkwy SW  
 Atlanta, GA 30336  
 USA  
 Tel. +1 404 924-6900  
 beko@bekousa.com

**US**