

Original installation and operation manual

BEKOMAT® Vario 20
BEKOMAT® Vario 20 FM

■ Table of contents

1. Notes about the documentation.....	5
1.1 Contact	5
1.2 Information about this installation and operation manual.....	5
2. Safety.....	6
2.1 Use	6
2.1.1 Intended use.....	6
2.1.2 Reasonably foreseeable inappropriate use.....	7
2.2 Responsibility of the operating company	7
2.3 Target group and personnel.....	8
2.4 Explanation of the safety symbols used.....	9
2.5 Safety instructions and warning notices.....	10
2.5.1 Basic safety instructions.....	10
2.5.2 Safe operation.....	10
2.5.3 Sudden escape of pressurised fluids	11
2.5.4 Electric voltage	11
2.5.5 Transport and storage.....	12
2.5.6 Installation.....	12
2.5.7 Maintenance	13
2.5.8 Handling hazardous substances.....	13
2.5.9 Working on electronic components	14
2.5.10 Use of spare parts, accessories or materials	14
2.6 Warning notices	14
3. Product information	15
3.1 Scope of delivery	15
3.2 Product overview	15
3.3 Exploded view BEKOMAT® 20 Vario	16
3.4 Exploded view BEKOMAT® 20 Vario FM.....	17
3.5 Function description	18
3.6 Type plate	19
3.7 Installation dimensions.....	19
4. Technical data	20
4.1 Operating parameters	20
4.2 Storage and transportation parameters	21
4.3 Materials.....	21
4.4 Screw fastening torques	21
4.5 Dimensions.....	22
4.6 Terminal diagrams.....	23
4.6.1 Power control board AC.....	23
4.6.2 Power control board DC.....	23
5. Transport and storage.....	24
5.1 Transport	24
5.2 Storage.....	24

6. Installation procedure	25
6.1 Warning notices	25
6.1.1 Installation dos and don'ts.....	25
6.2 Installation steps.....	27
7. Electrical installation	29
7.1 Connection work	29
7.1.1 Electrical supply connection.....	30
7.1.1.1 Power control board AC	30
7.1.1.2 Power control board DC	34
7.1.2 Connecting the dry contact.....	38
7.1.3 Connection of external TEST button	39
8. Start-up procedure	40
8.1 Warning notices	40
8.2 Start-up steps	40
9. Operation.....	41
9.1 Warning notices	41
9.2 Operating states	41
9.2.1 BEKOMAT® 20 Vario.....	41
9.2.2 BEKOMAT® 20 Vario FM.....	43
9.2.2.1 Filter management function reset	44
10. Maintenance.....	45
10.1 Warning notices	45
10.2 Maintenance schedule	46
10.3 Maintenance work	46
10.3.1 Wear part replacement	46
10.3.2 Functional test.....	49
10.3.3 Visual inspection.....	49
10.3.4 Leakage test	49
10.3.5 Cleaning.....	50
11. Consumables, accessories and spare parts	51
11.1 Order information.....	51
11.2 Accessories.....	51
11.3 Spare parts and set of seals	51
12. Shut-down procedure	52
12.1 Warning notices	52
12.2 Shut-down steps.....	52
13. Dismounting procedure	53
13.1 Warning notices	53
13.2 Dismounting steps	54


14. Disposal.....	55
14.1 Warning notices	55
14.2 Disposal of operating and auxiliary materials	56
14.3 Disposal of components	56
15. Troubleshooting	57
16. Appendices.....	58
16.1 Approval certificates and declarations of conformity.....	58
17. Declaration of Conformity	60
18. Notes	63

1. Notes about the documentation


This documentation contains all the necessary steps for the use and operation of the product and the accessories.

1.1 Contact

Manufacturer	Customer service and tools
BEKO TECHNOLOGIES GmbH Im Taubental 7 41468 Neuss Phone: +49 2131 988-1000 info@beko-technologies.com www.beko-technologies.com	BEKO TECHNOLOGIES GmbH Im Taubental 7 41468 Neuss Phone: +49 2131 988-1000 service-eu@beko-technologies.com www.beko-technologies.com

INFORMATION	Country-specific manufacturer representation
	You can contact the country-specific manufacturer's representative via the address listed in the address section on the rear cover or by using the contact form on the manufacturer's website.


1.2 Information about this installation and operation manual

INFORMATION	Copyright protection
	The contents of the installation and operation manual in the form of text, figures, illustrations, photographs, technical drawings, diagrams and other representations are protected by the copyright of the manufacturer. The distribution as well as the duplication of this document, the exploitation and the communication of its contents are prohibited unless expressly authorised.

Publication date	Revision	Version	Reason for amendment	Scope of amendment
24 June 2021	01	00	Editorial revision	Editorial changes
1 September 2022	02	00	Change in technical data	Change in technical data
1 February 2024	03	00	Editorial revision	Editorial changes

The installation and operation manual, hereinafter referred to as the manual, must always be kept close to the product and be in a permanently legible condition.

The manual must be handed over along with the product if it is sold or passed on.

NOTE	Follow the instructions given in the manual
	This manual contains all the basic information required for safe operation of the product and must be read before any actions are performed. Otherwise personal and material hazards as well as malfunction and device failure are possible.

2. Safety

2.1 Use

The **BEKOMAT® Vario 20 / Vario 20 FM**, also referred to in the following as the product or **BEKOMAT®**, is an electronically level-controlled condensate drain used for discharging condensate in pressurised systems. The **BEKOMAT®** is able to drain condensate at operating pressure with no pressure loss.

2.1.1 Intended use

Any use of this system other than the use described in this manual is hereby deemed to be non-intended and can cause a hazard for the safety of people and the environment.

The following must be noted for intended use:

- Read and follow the manual.
- Only use the product and the accessories in indoor areas.
- Only use the product and accessories within the operating parameters given in the “Technical Data”.
- Use the product and the accessories exclusively within the operating parameters and agreed terms of supply specified in the “Technical data” section.
- Only use the product and accessories with media which are free of caustic, aggressive, corrosive, toxic, flammable, oxidising and inorganic components. In cases of doubt an analysis must be carried out.
- Only use the product and accessories in surroundings where splash water is the maximum possible water exposure that can occur. The splash water must be free of corrosive components.
- Only use the product and accessories in areas which are free of toxic and corrosive chemicals and gases.
- Use the product and accessories only within a piping system designed for the operating parameters specified in section „4. Technical data“ on page 20, with appropriate connections, pipe diameters and installation clearances.
- Only use the product and accessories outside potentially explosive atmospheres.
- Only use the product and accessories away from direct solar radiation and heat sources as well as areas subject to frost.
- Only combine the product and the accessories with the recommended manufacturer products and components indicated in this manual.
- Adhere to the prescribed maintenance schedule.

Before using the product and the accessories, the operating company must make sure that all conditions and prerequisites for intended use are given.

The product and the accessories have been exclusively designed for stationary use in a commercial or industrial area. All of the assembly, installation, operation, maintenance, dismounting and disposal work described must be performed exclusively by qualified skilled technical personnel.

2.1.2 Reasonably foreseeable inappropriate use

A case of reasonably foreseeable inappropriate use is deemed to have occurred if the product or the accessories are used in any other way than that described in the "Intended use" section. Reasonably foreseeable inappropriate use includes the use of the product or the accessories in a manner not intended by the manufacturer or supplier but which may result from foreseeable human behaviour.

Reasonably foreseeable inappropriate use includes:

- The execution of any kind of modification, in particular constructive and process-technology related interventions.
- The suspension, bridging or non-application of existing or recommended safety equipment.
- Using the product and accessories in piping systems with carbon dioxide as the operating medium.

This list is not exhaustive as not all possible inappropriate use can be foreseen in advance. If the operating company is aware of any inappropriate use of the product or accessories which are not listed here, the manufacturer must be informed immediately.


2.2 Responsibility of the operating company

The responsible operating company must ensure the following to prevent accidents, incidents and adverse effects on the environment:

- Before all actions, check to ensure that the manual available does in fact belong to the product.
- The product and the accessories are used, serviced and repaired in accordance with the intended use.
- The product and accessories are only used with the recommended and fully operable safety equipment.
- All assembly, installation and maintenance work is carried out by qualified skilled technical personnel only.
- Personnel have the necessary personal protective equipment available and also use this equipment.
- Suitable technical safety measures are taken so that the permissible operating parameters are adhered to.
- Keep all safety symbols and the type plate on the product in a legible state. Replace damaged and illegible marking immediately.

2.3 Target group and personnel

This manual addresses the personnel listed below who are involved with work on the product or the accessories.

INFORMATION	Personnel requirements
	<ul style="list-style-type: none"> • Minors are strictly prohibited from working with and on the product and its accessories. • The personnel may not execute any actions on the product or the accessories when they are under the influence of drugs, medications, alcohol or other substances that may impair their consciousness.

Operating personnel

Operating personnel are persons who are able to operate the product and the accessories safely on the basis of knowledge of the manual and instruction at the product and accessories. Operating personnel can recognise possible malfunctions and dangerous situations independently and arrange for corresponding measures.

Skilled technical personnel - transport and storage

Skilled technical personnel - transport and storage are people who, due to their training, professional experience and qualifications, have all the necessary skills to safely carry out and direct all actions relating to the transport and storage of the product, to independently identify potentially hazardous situations and to take measures to avert danger.

The skills required include, in particular, experience operating hoists, forklifts and lifting equipment and familiarity with locally applicable laws, standards and guidelines relating to transport and storage.

Skilled technical personnel - pressure equipment and systems

Skilled technical personnel specialising in pressure equipment and systems consists of people who, due to their training, professional experience and qualifications, have all the necessary skills to safely carry out and direct all actions relating to pressurised fluids and systems, to independently identify potentially hazardous situations, and to implement appropriate measures to avert any danger.

The skills required include, in particular, experience using measuring equipment and control equipment, as well as familiarity with locally applicable laws, standards and regulations for pressurised systems.

Skilled technical personnel - electrical engineering

Skilled technical personnel - electrical engineering are people who, due to their training, professional experience and qualifications, have all the necessary skills to safely carry out and direct all actions relating to electricity, to independently identify potentially hazardous situations and to take measures to avert danger.










The skills required include, in particular, experience in using electrical plants, measurement and control technology as well as familiarity with locally applicable laws, standards and regulations for dealing with electrical equipment and systems.

Skilled technical personnel - product servicing

Skilled technical personnel - product servicing are people who have the skills and qualifications stated in all the skilled personnel definitions named above. Skilled technical personnel - product servicing must have documented proof of training and authorisation for all work on the product.

2.4 Explanation of the safety symbols used

The symbols used below indicate safety-relevant and important information which must be adhered to when handling the product and to ensure safe and optimum operation.

Symbol	Description / explanation
	General warning symbol (danger, warning, caution)
	Warning: pressurised system
	Warning: electric voltage
	Read and follow the installation and operation manual
	General instruction symbol
	Wear safety footwear
	Use protective gloves (cut-proof and liquid-resistant)
	Wear safety goggles with side shields
	General information

2.5 Safety instructions and warning notices

This section provides an overview of all the important safety aspects for personal protection as well as for the safe and problem-free operation of the product and accessories.

The following sections list the dangers posed by this product and the accessories even with intended use. To minimise the risk of personal injury and damage to property and to avoid dangerous situations, observe the safety instructions listed and adhere to the warning notices in the other sections of this manual.

Basic warning notices and the necessary qualifications of skilled technical personnel are always listed at the beginning of the section in the “Warning notices” section.

Warning notices related to specific actions are printed directly before potentially hazardous procedures or sequences of actions.

Failure to observe safety instructions and warning notices can result in personal injury, malfunctions, device failure and damage to property.

2.5.1 Basic safety instructions

- Before starting work, refer to the technical documentation for the entire system and observe the overall operating instructions.
- Carry out a risk assessment before starting work on site (last minute risk assessment).
- Use suitable personal protective equipment for all work.
- Set up a safety area around the working area during all installation, maintenance and repair work.
- Use existing system-specific protection procedures (e.g., LOTO procedure) in order to safely de-energise and isolate the system or system sections.

2.5.2 Safe operation

The following actions may result in serious injury or death:

- Start-up and operation of the product and accessories outside the permissible limit values and operating parameters
- Unauthorised interference and unauthorised modifications of the product and accessories

To guarantee the safe operation of the product and accessories, observe the following:

- Observe the limits and operating parameters specified on the type plate and in the manual.
- Check whether the permissible operating parameters have been changed or restricted by the use of accessories.
- Observe the requirements regarding installation location and ambient conditions.
- Adhere to the maintenance intervals.

2.5.3 Sudden escape of pressurised fluids

The following situations may result in serious injury or death:

- Contact with fast or suddenly escaping fluids
- Bursting system parts
- Whipping of pressurised hoses and pipes

For the safe handling of pressurised systems, observe the following:

- Observe the following safety rules during all work:
 1. Shut down the system or system section.
 2. Secure the system or system section against restarting.
 3. Reduce the pressure in the system or all system sections to the ambient pressure.
e.g. by slowly releasing the pressure in a controlled manner via relief valves
 4. Lock out and tag out the system or system section so that it cannot be pressurised again.
- Check the pressurised system or system section for safety, contamination and possible damage.
- Before pressurisation, check all system connections for leak tightness and tighten if necessary.
- Make absolutely sure to charge the system or system section with pressure slowly.
- Avoid pressure blows and high differential pressures.
- Compensate any vibrations occurring in the pipe network by using vibration dampers.

2.5.4 Electric voltage

Contact with live electrical components may result in serious personal injury or death.

To ensure the safe handling of live components, observe the following:

- Only connect the product and the accessories to the power supply if they are free of faults and defects.
- Conduct electrical installation work in compliance with all locally applicable legal requirements and regulations.
- Provide a circuit breaker in the power supply within easy reach of the product.
→ The circuit breaker disconnects all current-carrying conductors.
- Connect the protective conductor (earth connection) according to regulations.
- Only operate the product and accessories with the cover complete and closed, the electronics housing closed, or the switch cabinet closed.
- Before starting work on the product:
 1. Disconnect
→ Disconnect the product from all poles and all sides
 2. Secure against restarting
 3. Determine the absence of voltage at all poles
→ With suitable and permissible measuring device (e.g. two-pole voltage tester)
 4. Earth and short circuit

2.5.5 Transport and storage

Inappropriate transport or storage may result in personal injury or damage to property.

In order to ensure safety during the transport and storage of the product and accessories, observe the following:

- Use personal protective equipment during all work with packaging material.
- Handle packaging, the product and accessories carefully.
- Transport and handle the product and accessories according to the markings on the packaging.
- Use only proper transportation, lifting and lashing equipment that is in proper working order.
- Use only transportation, lifting and lashing equipment that are rated for the total weight of the product.
- Always adhere to the permissible transport and storage parameters.
- Store the product and accessories only outside of areas exposed to direct sunlight and heat sources.

2.5.6 Installation

Inappropriate physical or electrical installation of the product and accessories may result in personal injury and damage to property as well as impair operation.

For safe physical and electrical installation, observe the following:

- Install the product, the accessories, and all parts and materials used so that they are not subject to mechanical tension.
- Check all plug-type connections for a correct fit.
- Avoid a stumbling hazard by routing cables and hoses accordingly.
- Avoid mechanical strain on the cables.
- Fix and fasten hoses in such a way that they cannot flap around.
- Install the inlet lines as fixed pipes.

2.5.7 Maintenance

Inappropriate completion of maintenance and repair work may result in serious personal injuries or death.

For safe maintenance and repairs, observe the following:

- Before starting work, depressurise the pressurised product and accessories and secure them against unintentional pressurisation.
- Before starting work, isolate the product and accessories from the power source and secure them against being switched back on again unintentionally.
- Only use materials approved for the respective application.
- Use only suitable tools that are in proper working order.
- Only use cleaned pipes and hoses that are free of dirt and corrosion.
- Never use abrasive or aggressive cleaning agents or solvents which could damage the outer coating (e.g. markings, type plate, corrosion protection, etc.).
- Never clean the device with hard or pointed implements.
- Use only the specified materials and media for cleaning.
- Observe statutory, local and in-house hygiene regulations.
- Pay attention to order and cleanliness during maintenance and repair work. Prevent contamination from entering the opened product or accessories. Store disassembled components and accessories directly in a safe place.
- After completing maintenance and repair work, remove all tools and cleaning agents used, as well as all parts that are no longer needed, from the work area.
- Only dispose of the product and accessories when cleaned and freed of any residue.
- Dispose of all components, parts, operating and auxiliary materials as well as cleaning agents professionally and in accordance with all locally applicable legal requirements and regulations.
- Dispose of electrical and electronic components using a specialist disposal company or return them to manufacturer.

2.5.8 Handling hazardous substances

Contact with condensate containing substances which endanger health and the environment can pose a health hazard, causing irritation and/or damage to the eyes, skin and mucous membranes. In addition, polluted condensate must be prevented from entering the sewerage system, waters or the ground.

For the safe handling of polluted condensate, observe the following:

- Use suitable protective equipment when handling condensate.
- Pick up and dispose of any leaking or spilled condensate in accordance with locally applicable legal requirements and regulations.

2.5.9 Working on electronic components

Electrostatic discharge (ESD) can cause damage to electronic components, and malfunctions, device failures or material damage are possible.

- Take proper measures to prevent electrostatic discharge (e.g. earthing, potential equalisation, ESD-compatible dissipative work pads etc.).

2.5.10 Use of spare parts, accessories or materials

The use of incorrect spare parts, accessories or materials, as well as auxiliary and operating materials, may result in death or serious injury. Malfunction and device failure as well as material damage can occur.


- Only use undamaged original parts, auxiliary and operating materials which are specified by the manufacturer to complete all work.
- Only use the materials approved for the respective application and suitable tools in proper working order.
- Only use cleaned pipes that are free of dirt and corrosion.
- Only use electric components and materials that comply with locally applicable legal requirements and regulations (standards, directives etc.) for electrical safety.

2.6 Warning notices

Warning notices warn against dangers when handling the product and accessories.

Observe the warning notices in order to avoid personal injury, damage to property and impaired operation.

Structural set up:

SIGNAL WORD	Type and source of danger
 Symbol	Possible consequences if the danger is ignored
	<ul style="list-style-type: none"> • Measures to prevent the danger

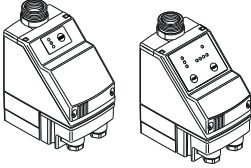

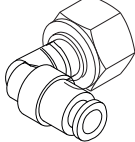
Signal words:

DANGER	Imminent hazard Consequences of non-compliance: Death or serious personal injury
WARNING	Imminent hazard Consequences of non-compliance: Death or serious personal injury are possible
CAUTION	Potential hazard Consequences of non-compliance: Personal injury or damage to property are possible
NOTE	Additional notes Consequences of non-compliance: Damage to property, malfunction and device failure are possible. No hazard to people or endangerment of safe operation.

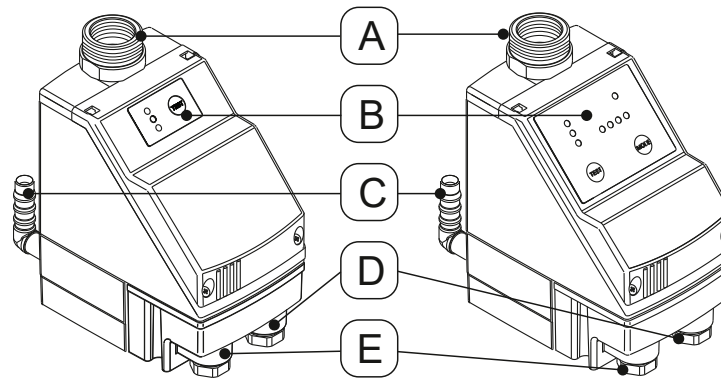
3. Product information

3.1 Scope of delivery

The table below shows the scope of delivery of the product:

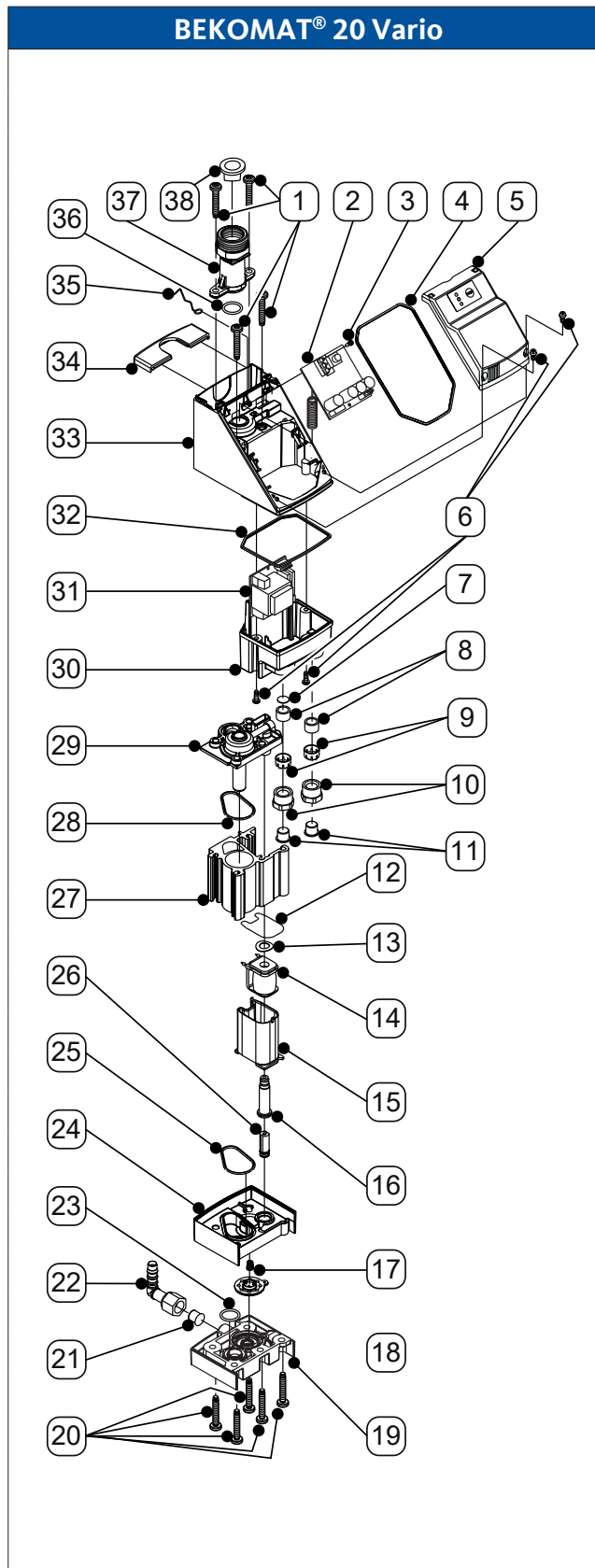
Illustration	Description / explanation
	<p>BEKOMAT® Vario 20 / Vario 20 FM</p>
	<p>Original installation and operation manual</p>
	<p>1 x elbow connector</p>

3.2 Product overview



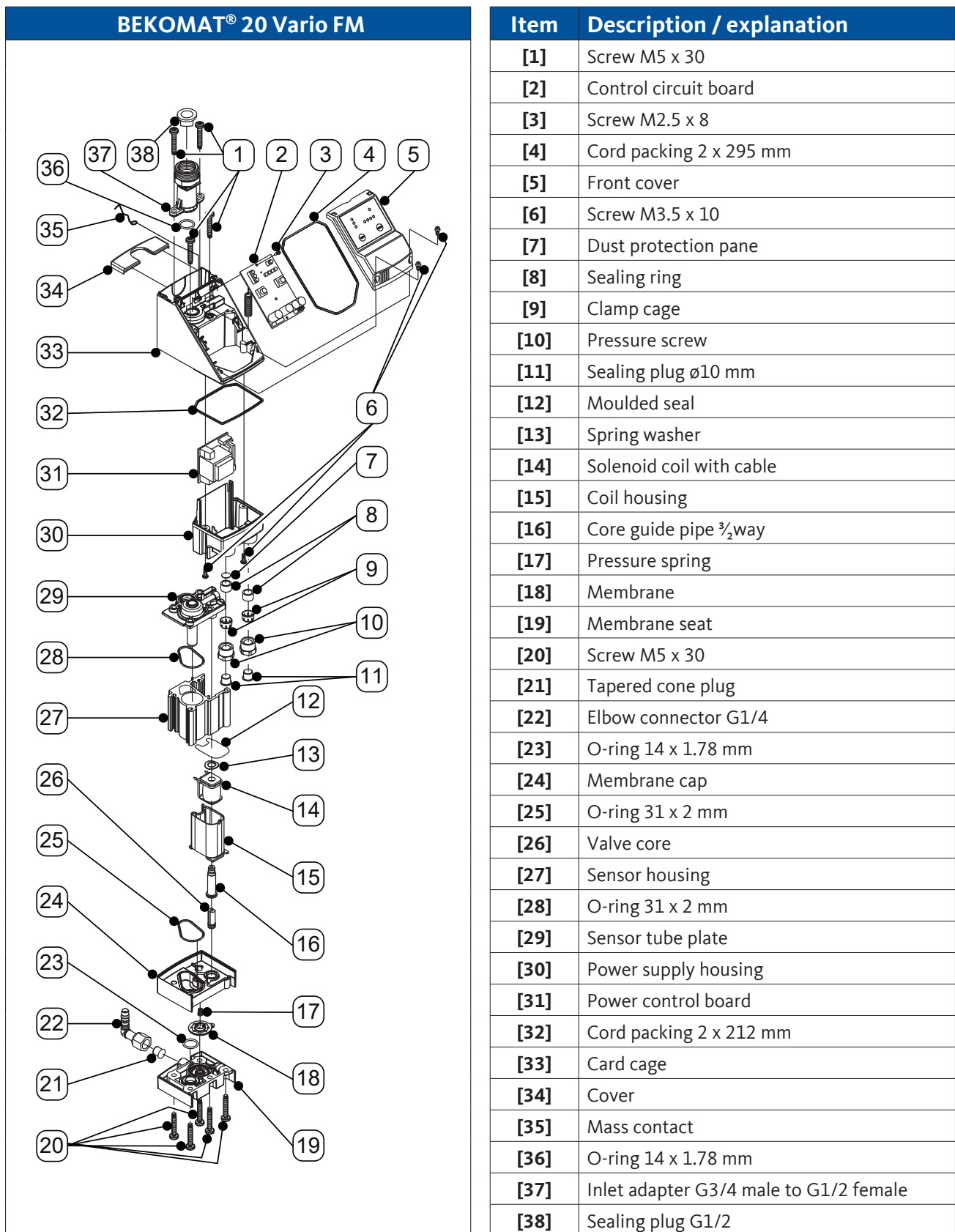
Pos. No.	Description	Pos. No.	Description
[A]	Condensate inlet	[D]	Cable gland right: Dry contact
[B]	Operating label	[E]	Cable gland left: Power supply
[C]	Condensate outlet		

3.3 Exploded view BEKOMAT® 20 Vario

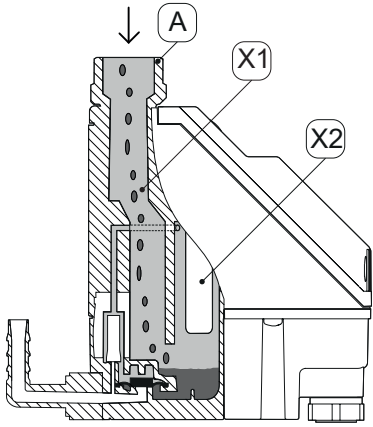
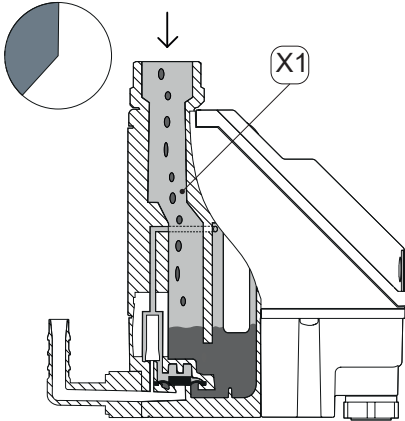
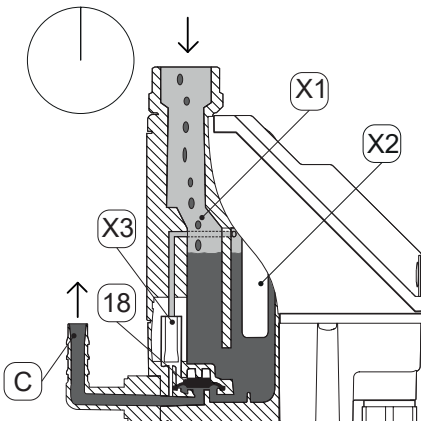
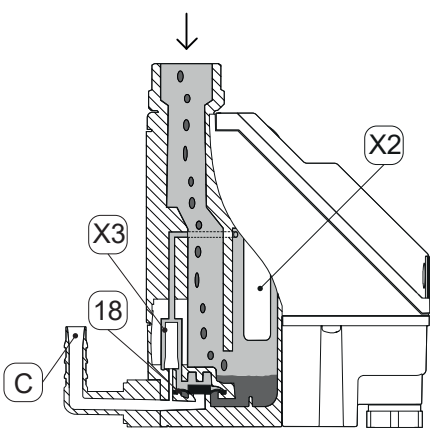


Item	Description / explanation
[1]	Screw M5 x 30
[2]	Control circuit board
[3]	Screw M2.5 x 8
[4]	Cord packing 2 x 295 mm
[5]	Front cover
[6]	Screw M3.5 x 10
[7]	Dust protection pane
[8]	Sealing ring
[9]	Clamp cage
[10]	Pressure screw
[11]	Sealing plug \varnothing 10 mm
[12]	Moulded seal
[13]	Spring washer
[14]	Solenoid coil with cable
[15]	Coil housing
[16]	Core guide pipe $\frac{3}{2}$ way
[17]	Pressure spring
[18]	Membrane
[19]	Membrane seat
[20]	Screw M5 x 30
[21]	Tapered cone plug
[22]	Elbow connector G1/4
[23]	O-ring 14 x 1.78 mm
[24]	Membrane cap
[25]	O-ring 31 x 2 mm
[26]	Valve core
[27]	Sensor housing
[28]	O-ring 31 x 2 mm
[29]	Sensor tube plate
[30]	Power supply housing
[31]	Control circuit board
[32]	Cord packing 2 x 212 mm
[33]	Card cage
[34]	Cover
[35]	Mass contact
[36]	O-ring 14 x 1.78 mm
[37]	Inlet adapter G3/4 male to G1/2 female
[38]	Sealing plug G1/2

3.4 Exploded view BEKOMAT® 20 Vario FM

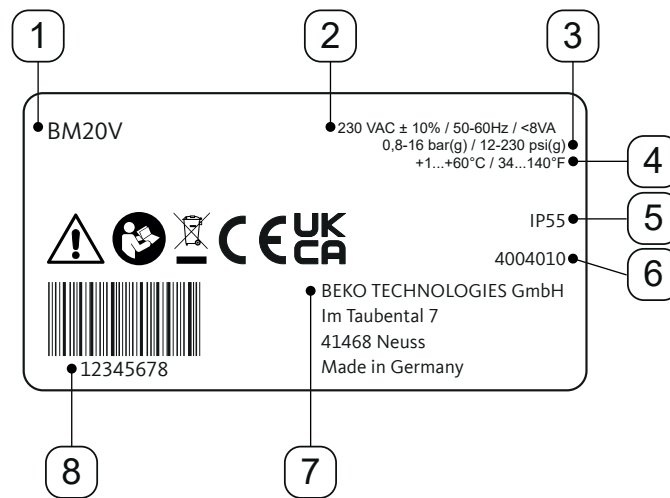


3.5 Function description

Illustration	Description / explanation
 <p>A cross-sectional diagram of the BEKOMAT unit. An arrow labeled 'A' points to the condensate inlet at the top. Below it is a chamber labeled 'X1' which is partially filled with condensate. A sensor tube labeled 'X2' extends from the top of chamber 'X1' down into the condensate. The unit is shown connected to a drainage system.</p>	<p>The condensate flows via the condensate inlet [A] into the BEKOMAT® and collects in the housing [X1]. The filling level in the housing [X1] is continuously monitored by a capacitive sensor in the sensor tube [X2].</p>
 <p>A cross-sectional diagram similar to the first one, but the condensate level in housing 'X1' has risen higher. A circular gauge icon in the top left corner shows a shaded segment, indicating that the sensor in tube 'X2' is now submerged.</p>	<p>Once the condensate has reached the maximum filling level, the pre-set waiting time in the controller is started. During the waiting time, the condensate level in the housing [X1] and the condensate inlet line increases continuously.</p>
 <p>A cross-sectional diagram showing the internal mechanism. A pilot valve labeled 'X3' is partially open. A membrane labeled '18' is being pushed upwards by the pressure of the condensate in housing 'X1'. This forces condensate through the valve into the outlet labeled 'C'. A circular gauge icon in the top left corner shows a full circle, indicating the sensor is no longer submerged.</p>	<p>Once the pre-set waiting time has expired, the controller switches the pilot valve [X3]. The area above the membrane [18] is depressurised. The membrane [18] lifts off the valve seat and the excess pressure in the housing [X1] forces the condensate into the condensate outlet [C].</p>
 <p>A cross-sectional diagram showing the valve 'X3' fully closed. The membrane '18' is now pressed firmly against its seat, sealing the outlet 'C'. The sensor tube 'X2' is still visible, and the gauge icon shows a shaded segment, indicating the sensor is submerged again.</p>	<p>When the sensor in the sensor tube [X2] is no longer covered by condensate, the controller switches the pilot valve [X3] and pressure builds up above the membrane [18]. The membrane [18] is pressed against the valve seat and the condensate outlet [C] is sealed tightly.</p>

3.6 Type plate

The type plate, which contains identification information and operating parameters for the product, is located on the bottom cover.



Example illustration

Pos. No.	Description / explanation
[1]	Product name
[2]	Operating voltage
[3]	Operating pressure
[4]	Operating temperature
[5]	IP protection class
[6]	Material number
[7]	Manufacturer
[8]	Serial number

For more information, see „2.4 Explanation of the safety symbols used“ on page 9.

3.7 Installation dimensions

Illustration	Description / explanation
	<p>When installing, leave sufficient clearance above the top cover so that the LEDs are visible and the TEST button can be pressed.</p>

4. Technical data

4.1 Operating parameters

BEKOMAT®	Vario 20 / Vario 20 FM
Relative ambient humidity	10 ... 80%, without condensation
Maximum operating height	2000 m 2187.23 yd
Minimum / maximum absolute operating pressure	0.8 ... 16 bar(g) 12 ... 230 psi(g)
Minimum / maximum operating temperature	+1 ... 60 °C +34 ... +158 °F
Average - discharge rate	75 l/h 19.81 gal/h
Maximum discharge rate (short-term)	75 l/h 19.81 gal/h
Connection*, condensate inlet	1 x G1/2 female max. screw-in depth 13.5 mm (1/2 in)
Connection, condensate outlet	1 x G1/4 male, hose connection for hose diameter 8 ... 10 mm internal (0.31 ... 0.39 in)
Media	Condensate, oil-contaminated or oil-free
Empty weight	0.7 kg 1.5 lbs
Operating voltage	230 / 115 / ... / 24 VAC ± 10%; 50 ... 60 Hz / 24 VDC ± 10% See type plate
Power consumption	P < 8.0 VA (W)
Degree of protection	IP55
Overvoltage category (IEC 61010-1)	II
Degree of pollution (IEC 61010-1)	3
Recommended cable diameter	5.8 ... 8.5 mm 0.23 ... 0.33 in
Recommended wire cross-sectional area (power supply)	0.75 ... 2.5 mm ² AWG 14 ... 20
Recommended shortening of the cable jacket	PE= ~ 60 mm L / N: ~ 50 mm PE= ~ 2.36 in L / N: ~ 1.97 in
Recommended stripping length of the cable wires	~ 6 mm ~ 0.24 in
Connection data for dry contact for switching load	AC: max. 250 V / 1A ; DC: max. 30 V / 1A
Connection data for dry contact for small signal	min. 5 VDC ; 10 mA
Connection data of external test contact	on the device side 5 VDC; switching current ≥ 0.5 mA

* The NPT thread version is available as an option.

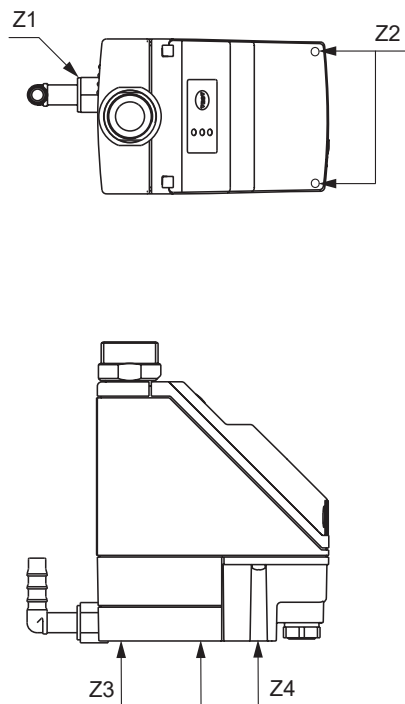
4.2 Storage and transportation parameters

BEKOMAT®	Vario 20 / Vario 20 FM
Minimum / maximum temperature, storage and transport	+1 ... +60 °C +34 ... +140 °F

4.3 Materials

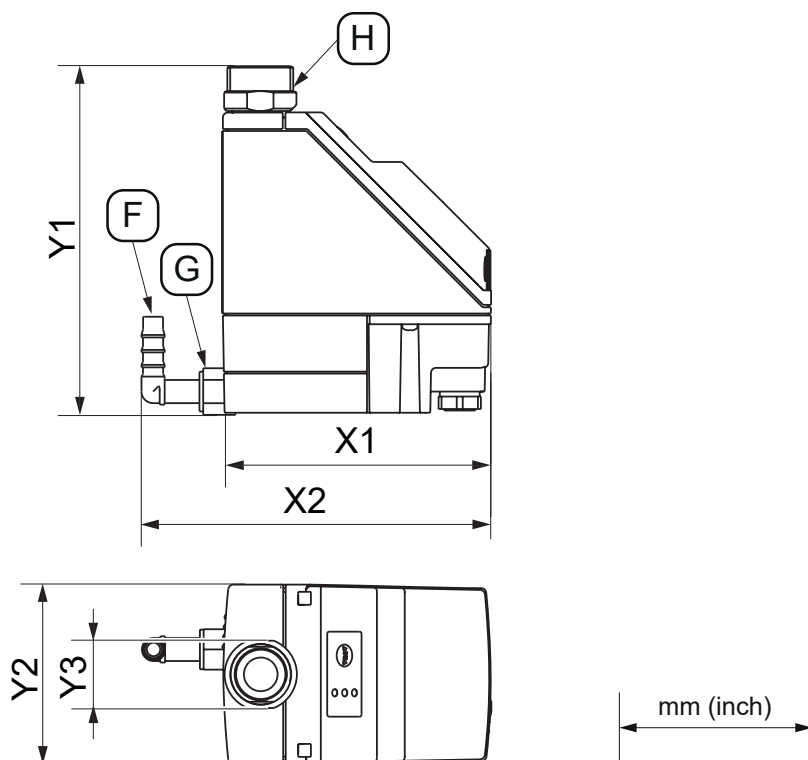
BEKOMAT®	Vario 20 / Vario 20 FM
Housing	Aluminium and plastic, glass fibre reinforced
Membrane	FKM

4.4 Screw fastening torques



Pos. No.	Description / explanation	Tightening torques
[Z1]	Elbow connector	3 Nm (2.21 ft-lb)
[Z2]	Screws, front cover	1.0 Nm +0.2 Nm (0.74 ft-lb +0.15 ft-lb)
[Z3]	Screws, membrane seat	3.5 Nm ±0.5 Nm (2.58 ft-lb +0.37 ft-lb)
[Z4]	Screws, power supply housing	1.0 Nm +0.2 Nm (0.74 ft-lb +0.15 ft-lb)

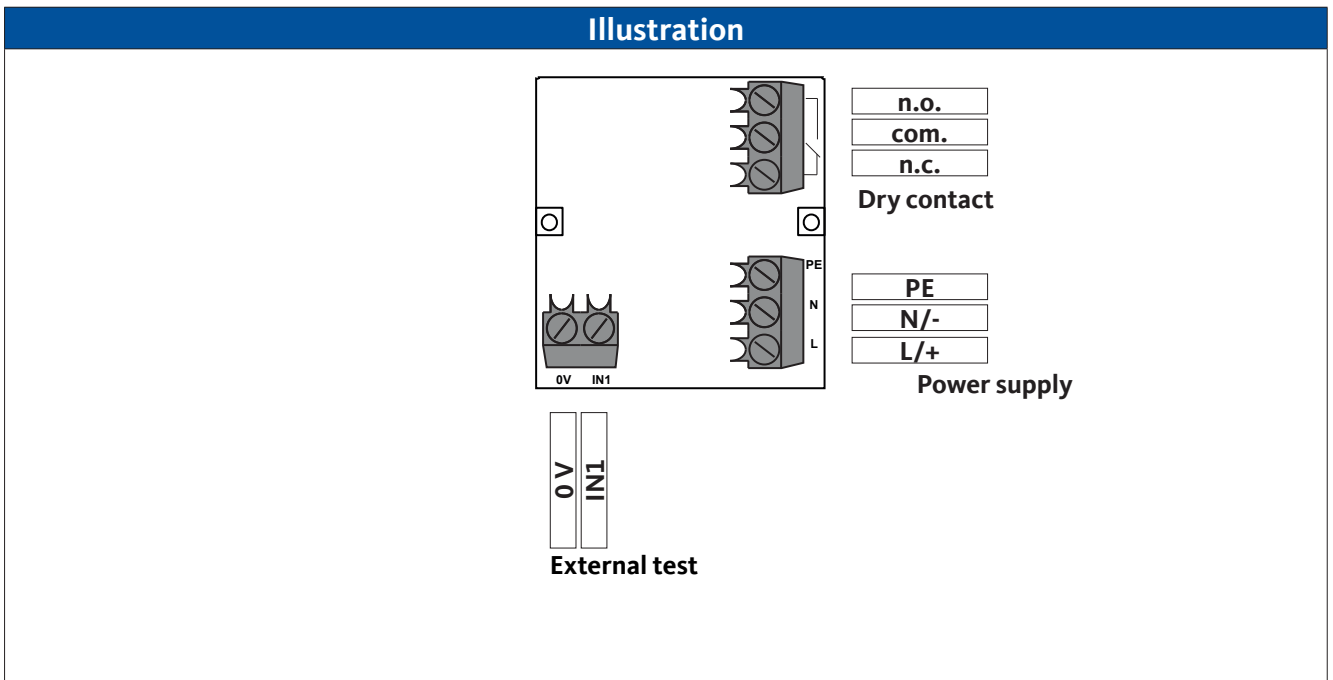
4.5 Dimensions



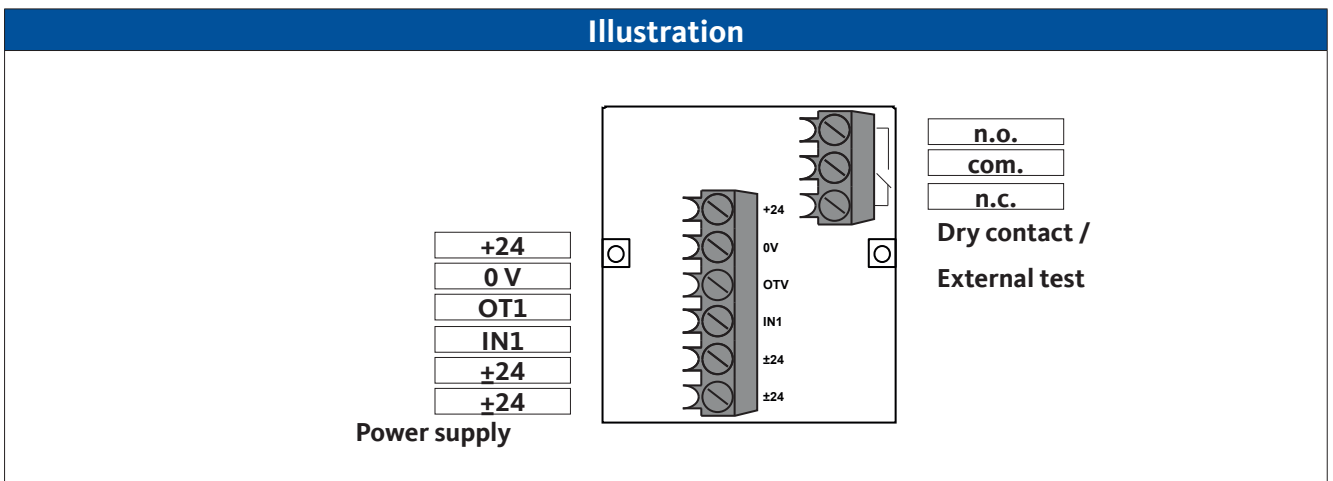
Splitting unit	BEKOMAT® Vario 20 / Vario 20 FM
[X1]	108 mm 4.25 in
[X2]	140 mm 5.51 in
[Y1]	140 mm 5.51 in
[Y2]	72 mm 2.83 in
[Y3]	SW27
[F] - Connection, barbed hose fitting	8 ... 10 mm internal 0.31 ... 0.39 in
[G] - Connection, condensate outlet	G1/4" NPT 1/4"
[H] - Connection, condensate inlet	G1/2" NPT 1/2"

4.6 Terminal diagrams

4.6.1 Power control board AC





4.6.2 Power control board DC



5. Transport and storage

Personnel

Skilled technical personnel - transport and storage (see section „2.3 Target group and personnel“ on page 8)

CAUTION	Inappropriate transport or storage
	<p>Inappropriate transport or storage may result in personal injury or damage to the device.</p> <ul style="list-style-type: none"> • Use personal protective equipment during all work with packaging material. • Handle packaging, the product and accessories carefully. • Use only proper transportation, lifting and lashing equipment that is in proper working order. • Use only transportation, lifting and lashing equipment that are rated for the total weight of the product. • Always adhere to the permissible transport and storage parameters.
NOTE	Dealing with packaging material
	<p>Inappropriate disposal of packaging materials can cause environmental damage.</p> <ul style="list-style-type: none"> • Dispose of the packaging material in accordance with the applicable legal requirements and provisions of the country and place of use.

5.1 Transport

After transporting and removing the packaging material, inspect the product for possible transport damage. If you find any damage, notify the carrier company, the manufacturer or one of its agents immediately.

Transport the product as follows:

- Only transport the product in its original packaging.
- Handle packaging and the product with care.
- Note the transport weight specification and marking on the packaging.
- Secure the packaging and the product against slipping and falling during transport.
- Pack all parts impact-proof using suitable material.

5.2 Storage


Store the product and the accessories as follows:

- Adhere to the storage parameters in section „4.2 Storage and transportation parameters“ on page 21.
- Store in a closed, dry as well as frost-free room.
- Store protected from external influences of the weather, direct sunlight and sources of heat.
- Secure against falling over and protect against vibrations at the storage location.

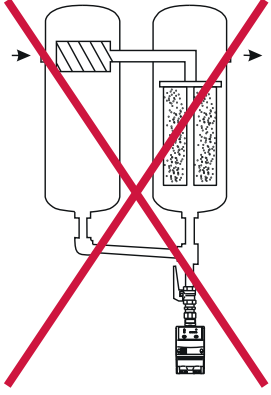
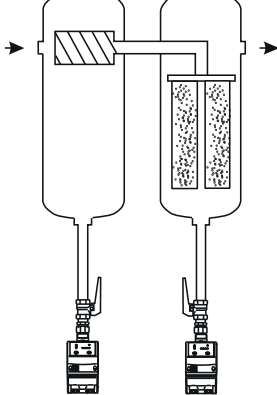
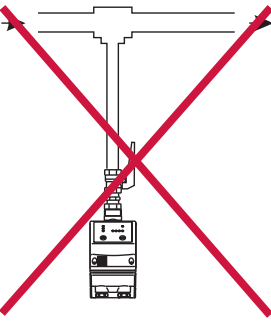
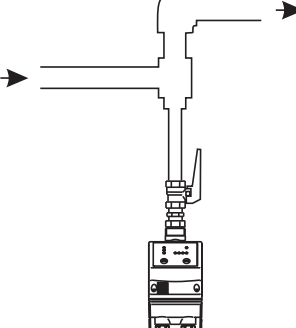
6. Installation procedure

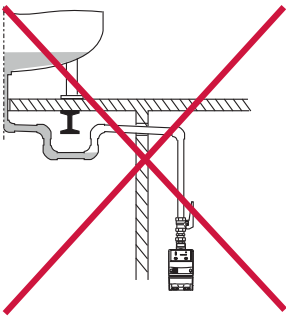
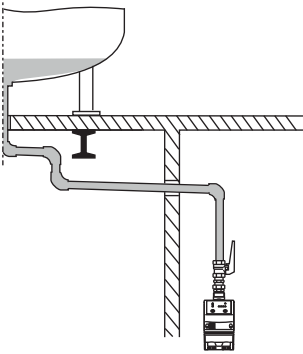
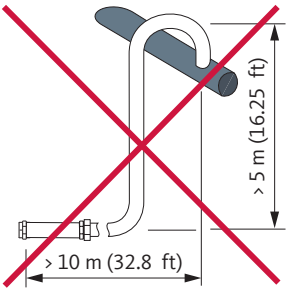
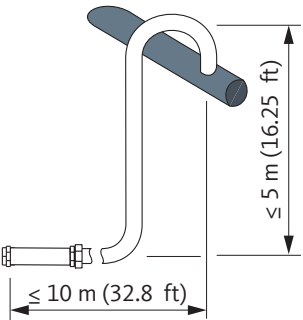
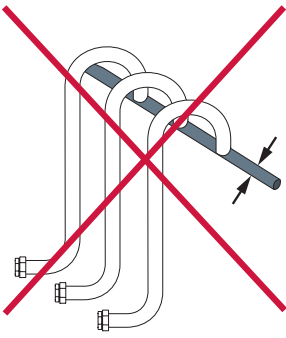
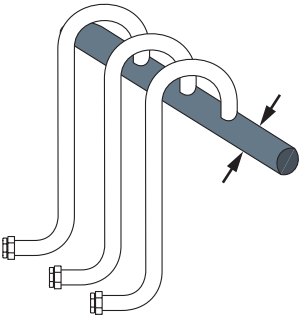
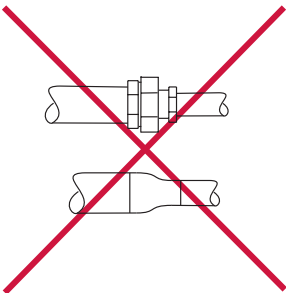
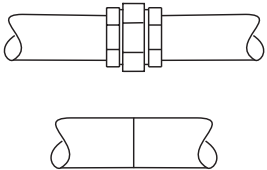
6.1 Warning notices

Personnel	
Skilled technical personnel - pressure equipment and systems (see section „2.3 Target group and personnel“ on page 8)	

DANGER	Sudden escape of pressurised fluids
	<p>There is a danger of death or serious personal injury resulting from contact with fast or suddenly escaping fluids or through bursting system parts.</p> <ul style="list-style-type: none"> • Before starting work, depressurise the pressurised system and secure it against unintentional pressurisation. • Assemble all pipes and hoses free of mechanical stress.


6.1.1 Installation dos and don'ts

Wrong	Right	Description / explanation
		<p>Bypassing filters</p> <ul style="list-style-type: none"> • Discharge each condensate collection point with a separate BEKOMAT®. • Do not create filter bypasses.
		<p>Discharge from pressurised pipes</p> <ul style="list-style-type: none"> • Divert the flow of gas to provide a deflecting surface to discharge the fluid components in the gas.

Wrong	Right	Description / explanation
		<p>Continuous fall > 3% in pipes</p> <ul style="list-style-type: none"> When installing the inlet line pipe, ensure a continuous fall (downward gradient) > 3%. Make sure that no water pockets form.
		<p>Drain line design</p> <ul style="list-style-type: none"> Do not use shut-off valves in the drain line. Only connect the BEKOMAT® to the drain line using a hose. <ul style="list-style-type: none"> → The hose compensates for installation tolerances, vibrations and thermal expansion. Do not route the drain line on or across storage or transportation surfaces. The drain line may be a maximum of 10 m (32.8 ft) long and installed at a maximum of 5 m (16.25 ft) rise. <ul style="list-style-type: none"> → The minimum operating pressure increases by 0.1 bar(g) (1.5 psi(g)) per metre of rise.
		<p>Manifold design</p> <ul style="list-style-type: none"> The cross-sectional area of the manifold must be at least equal to the sum of the individual cross-sectional areas of the connected lines feeding into it. Route the manifold with a continuous downward gradient >3%.
		<p>Observe the minimum pipe diameter</p> <ul style="list-style-type: none"> The minimum inside diameter of the inlet line and drain line is 13 mm (0.5 in). Do not restrict or reduce the (minimum) pipe diameter with reducers (reducing nipple fittings).

6.2 Installation steps

For installation work to be carried out, the following prerequisites must be fulfilled and the preparatory tasks must have been completed.

Prerequisites		
Tools	Material	Protective equipment
<ul style="list-style-type: none"> Combination wrench or adjustable wrench 	<ul style="list-style-type: none"> Sealants e.g. PTFE Inlet line Drain line Hose, interior diameter 8 ... 10 mm (0.31 ... 0.39 in), length approx. 30 cm (1 ft) Hose clamp 	<p>Always to be worn:</p> 

Preparatory tasks	
1.	Depressurise the pressurised system or the respective system section and secure it against unintentional pressurisation.
2.	Get the hose and hose clamp ready for connection to the condensate outlet.

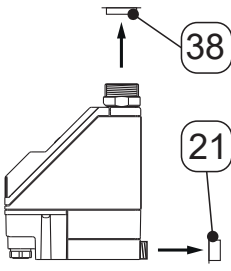
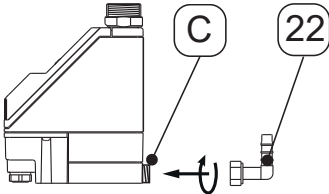
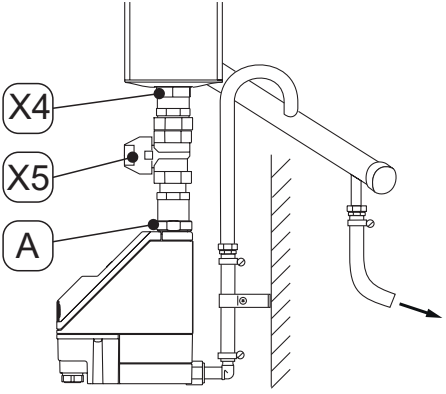
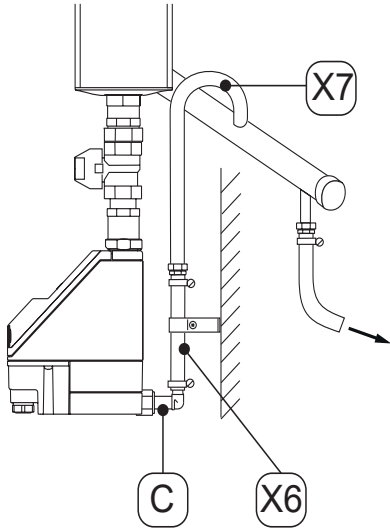
Illustration	Description / explanation
	<p>1. Remove the plugs [38, 21].</p>
	<p>2. Screw the supplied hose connection [22] onto the condensate outlet [C].</p>

Illustration	Description / explanation
 <p>The illustration shows a cross-section of the BEKOMAT 20 Vario / 20 Vario FM unit. A vertical pipe labeled X4 enters the unit from the top. A shut-off valve labeled X5 is installed on this pipe. The pipe then turns horizontally and then vertically down into the unit, where it is labeled A. A separate pipe is shown exiting the unit to the right, with an arrow indicating the direction of flow.</p>	<p>Recommendation:</p> <ol style="list-style-type: none"> 3. To ensure easy maintenance of the product, install a shut-off valve [X5] in the condensate inlet line [X4]. 4. For the condensate inlet line [X4], apply sealant to the end of a pressure-resistant pipe and screw it into the condensate inlet [A].
 <p>The illustration shows the same unit as above, but with a hose labeled X6 connected to a hose connection labeled C on the side of the unit. The other end of the hose X6 is connected to a condensate drain line labeled X7, which is shown exiting the unit to the right. An arrow indicates the direction of flow for the drain line.</p>	<ol style="list-style-type: none"> 5. For the condensate outlet, push the hose provided [X6] onto the hose connection [C] and fasten it with a hose clamp. 6. Connect the other end of the hose [X6] to the condensate drain line [X7].



Final steps

1. Before pressurisation, check all system connections for leak tightness and tighten if necessary.

7. Electrical installation


Personnel

Skilled technical personnel - electrical (see section „2.3 Target group and personnel“ on page 8)

DANGER	Electric voltage
	<p>Contact with live electrical components may result in serious personal injury or death.</p> <ul style="list-style-type: none"> • Only carry out installation, maintenance and repair work on the product and accessories after they have been isolated from the power source and secured against being switched back on again unintentionally. • Conduct electrical installation work in compliance with all locally applicable legal requirements and regulations. • Connect the protective conductor (earth connection) according to regulations.
WARNING	Ingress of moisture or foreign bodies
	<p>Removing components or opening the product may allow water or foreign bodies to enter the opened product. This can lead to accidents, personal injury and damage to property as well as impairments in operation.</p> <ul style="list-style-type: none"> • Protect the product from splashing water or moisture. • Only open the product or remove components in a dry place. • Do not insert any foreign bodies into the openings of the product. • Keep all contact surfaces and openings free of dirt and moisture.

7.1 Connection work

For connection work to be carried out, the following prerequisites must be fulfilled and the preparatory tasks must have been completed.

Prerequisites		
Tools	Material	Protective equipment
<ul style="list-style-type: none"> • Stripping tool • Crimping tool for wire-end ferrules • Screwdriver - cross-head size PZ2 • Screwdriver - flat-head size 2.5 mm (0.09") 	<ul style="list-style-type: none"> • 3-wire shielded connection cable: 3 wires for current supply • 3-wire shielded connection cable: 3 wires for dry contact • 2-wire shielded connection cable: 2 wires for external TEST button • Wire-end ferrules 	<p>Always to be worn:</p> 

Preparatory tasks

1.	The product has been physically installed (see section „6. Installation procedure“ on page 25).
----	---

7.1.1 Electrical supply connection

7.1.1.1 Power control board AC

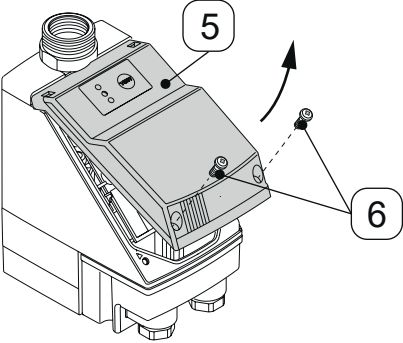
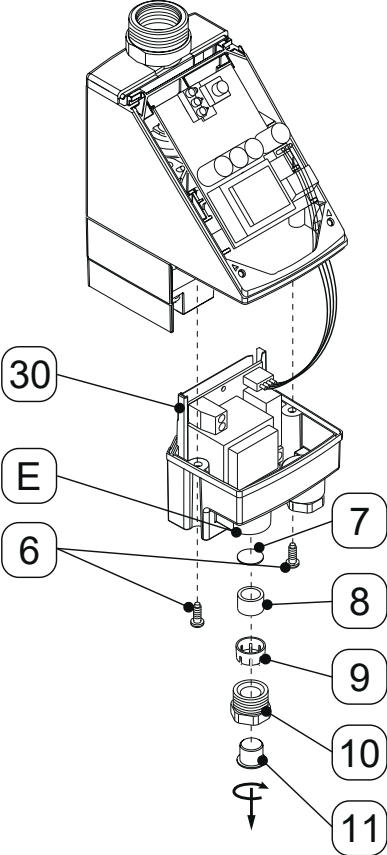
Illustration	Description / explanation
	<ol style="list-style-type: none"> 1. Loosen the screws [6] of the top cover [5] and lift the top cover [5] off.
	<ol style="list-style-type: none"> 2. Unscrew and remove the components [7, 8, 9, 10, 11] of the cable gland on the left [E]. 3. Loosen the 2 screws [6] of the power supply housing [30] and take the power supply housing [30] off.

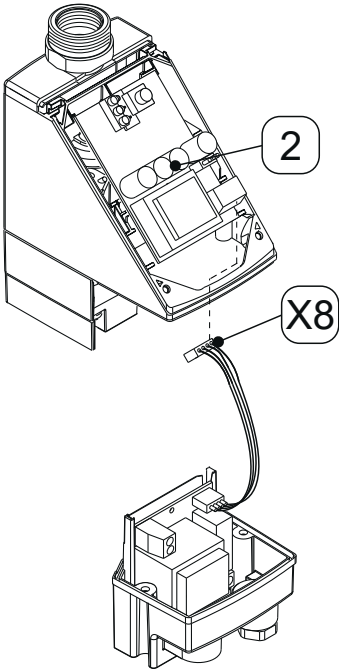
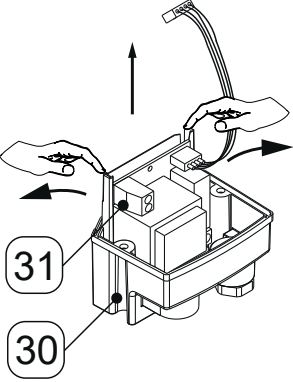
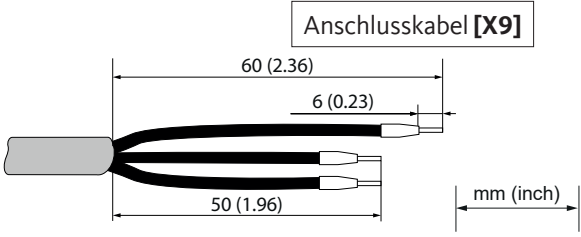
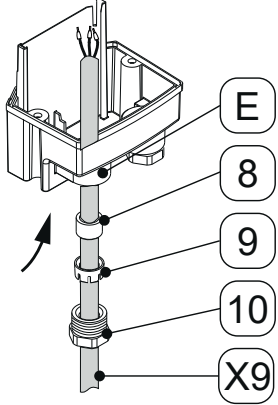
Illustration	Description / explanation
	<p>4. Pull the plug-type connector [X8] off the control circuit board [2].</p>
	<p>5. Ease the rails of the power supply housing [30] slightly apart using your fingers, and pull the power control board [31] up and out.</p>
 <p>Anschlusskabel [X9]</p>	<p>6. Prepare the power connection cable [X9].</p>
	<p>7. Fit the cable gland components [8, 9, 10] over the power connection cable [X9] and insert the cable into the cable gland on the left [E].</p>

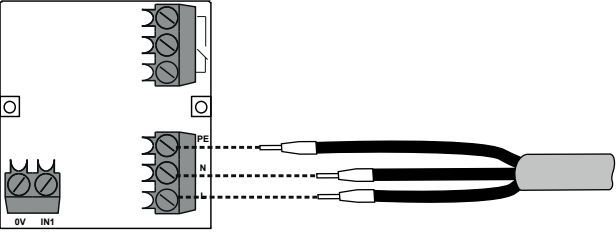
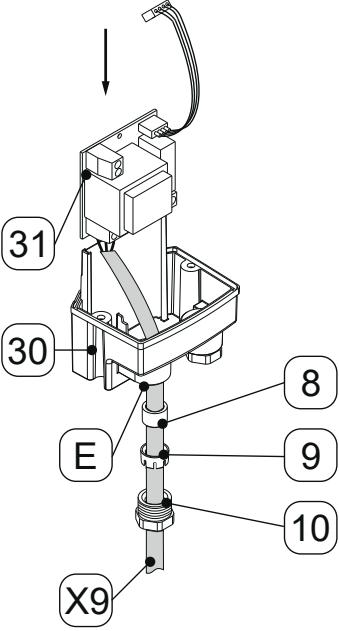
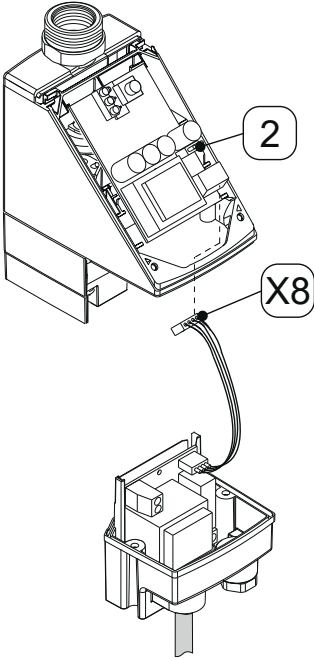
Illustration	Description / explanation
	<p>8. Connect the power connection cable [X9] in accordance with the terminal diagram „4.6 Terminal diagrams“ on page 23.</p>
	<p>9. Insert the power control board [31] back into the power supply housing [30].</p> <p>10. Pull the power connection cable [X9] taut while doing so and screw the counter nut [10] with the components [8, 9] back into the cable gland on the left [E].</p>
	<p>11. Connect the plug-type connector [X8] to the control circuit board [2].</p>

Illustration	Description / explanation
The illustration shows two views of the power supply housing assembly. The top view shows the housing [30] being pushed back into its position on the main unit. The bottom view shows the housing [30] fully seated, with two screws [6] being inserted into the base to secure it. Dashed lines indicate the alignment and movement of the housing.	<p>12. Push the power supply housing [30] back into place and secure it with the screws [6].</p>
The illustration shows four views of the top cover assembly. The top-left view shows the top cover [5] being placed onto the main unit. The top-right view shows the top cover [5] fully seated. The bottom-left view shows the top cover [5] being fastened with screws [6]. The bottom-right view shows the top cover [5] incorrectly placed, with a red 'X' over it, indicating that it should not be fastened in this position.	<p>13. Set the top cover [5] in place as shown and fasten using the screws [6].</p>

7.1.1.2 Power control board DC

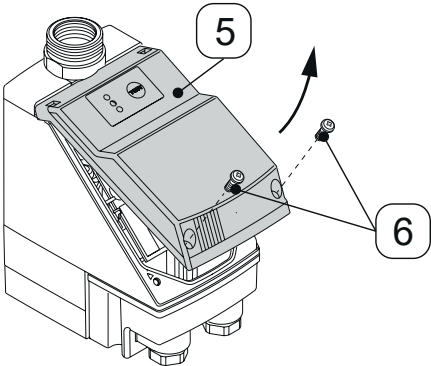
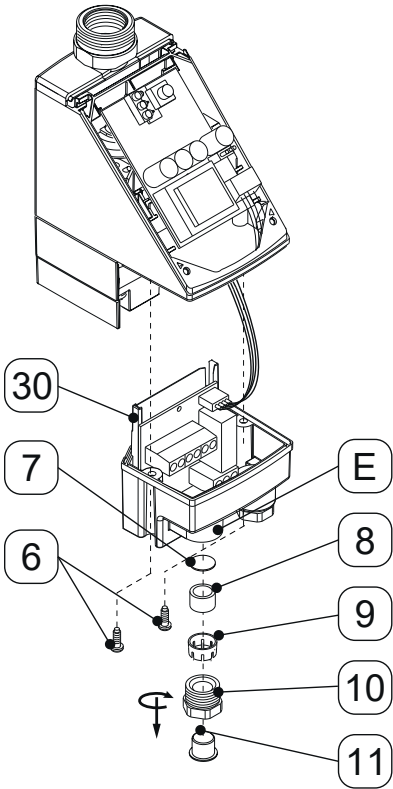
Illustration	Description / explanation
	<ol style="list-style-type: none"> 1. Loosen the screws [6] of the top cover [5] and take the top cover [5] off.
	<ol style="list-style-type: none"> 2. Unscrew and remove the components [7, 8, 9, 10, 11] of the cable gland on the left [E]. 3. Loosen the screws [6] of the power supply housing [30] and take the power supply housing [30] off.

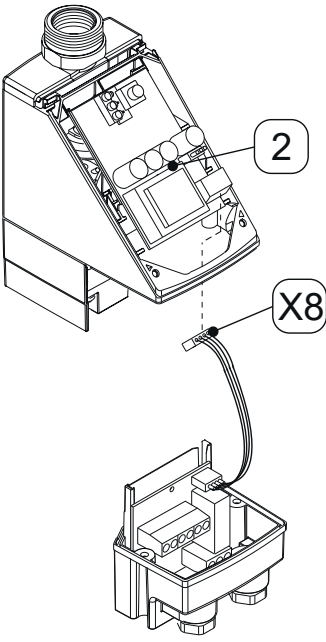
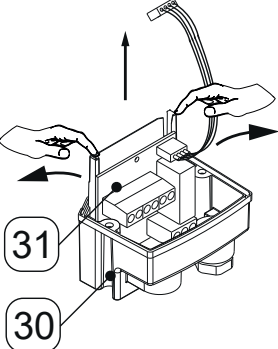
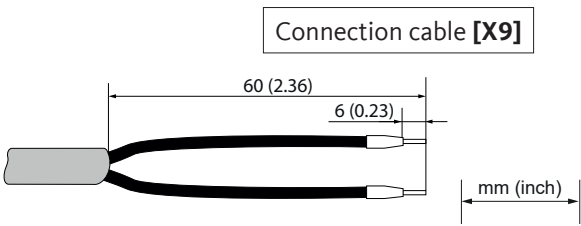
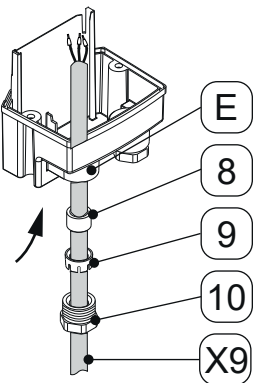
Illustration	Description / explanation
	<p>4. Pull the plug-type connector [X8] off the control circuit board [2].</p>
	<p>5. Ease the rails of the power supply housing [30] slightly apart using your fingers, and pull the power control board [31] up and out.</p>
 <p>Connection cable [X9]</p> <p>60 (2.36)</p> <p>6 (0.23)</p> <p>mm (inch)</p>	<p>6. Prepare the power connection cable [X9].</p>
	<p>7. Fit the cable gland components [8, 9, 10] over the power connection cable [X9] and insert the cable into the cable gland on the left [E].</p>

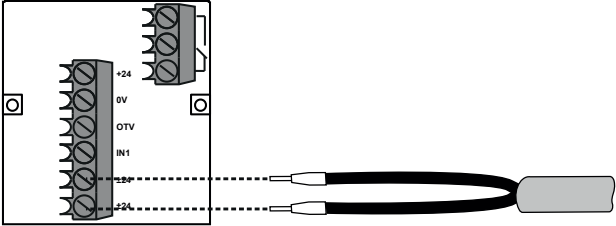

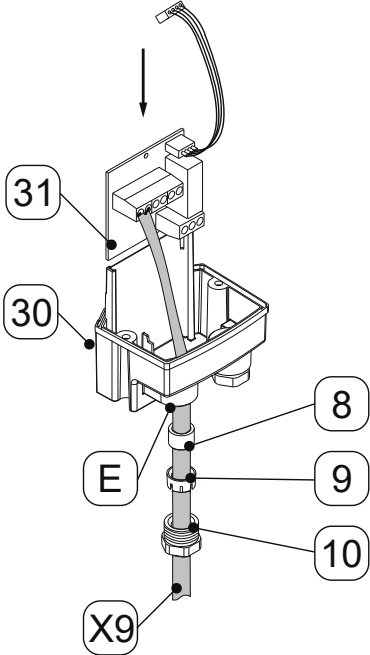
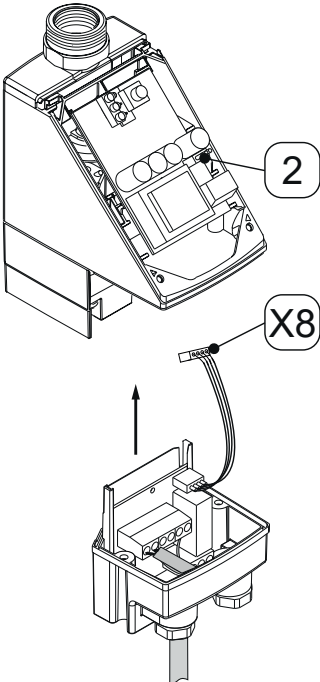
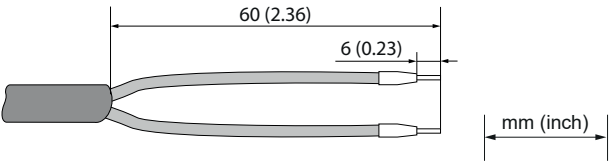

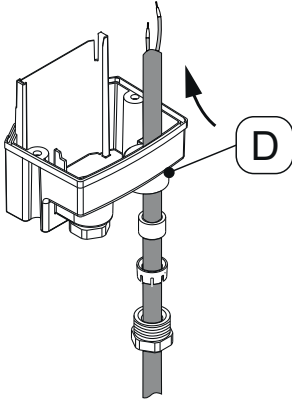
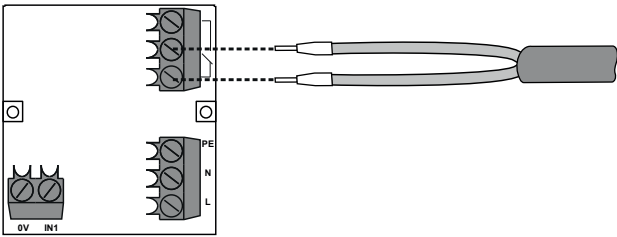
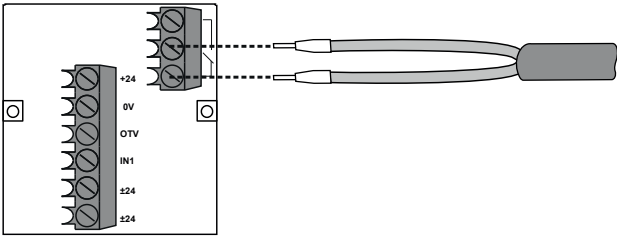
Illustration	Description / explanation
	<p>8. Connect the power connection cable [X9] in accordance with the terminal diagram „4.6 Terminal diagrams“ on page 23.</p> <p> In the case of 24 VDC operation there is no galvanic isolation between the power supply and the BEKOMAT® electronics. The housing is connected to the circuit ground.</p>
	<p>9. Insert the power control board [31] back into the power supply housing [30].</p> <p>10. Pull the power connection cable [X9] taut while doing so and screw the counter nut [10] with the components [8, 9] back into the cable gland on the left [E].</p>
	<p>11. Connect the plug-type connector [X8] to the control circuit board [2].</p>

Illustration	Description / explanation
The illustration shows two views of the power supply housing assembly. The top view shows the housing [30] being pushed back into its designated slot. The bottom view shows the housing [30] fully seated, with two screws [6] being inserted from the bottom to secure it. Dashed lines indicate the alignment and the path of the screws.	<p>12. Push the power supply housing [30] back into place and secure it from below using the screws [6].</p>
The illustration shows four views of the top cover [5] installation. The top-left view shows the cover [5] being placed onto the unit. The top-right view shows the cover [5] being pushed down into place, with an arrow indicating the direction of movement. The bottom-left view shows the cover [5] fully seated, with two screws [6] being inserted from the bottom to fasten it. The bottom-right view shows the cover [5] not properly seated, with a large red 'X' over it, indicating that this is an incorrect installation method.	<p>13. Set the top cover [5] in place as shown and fasten using the screws [6].</p>

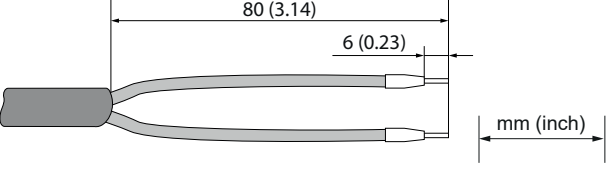

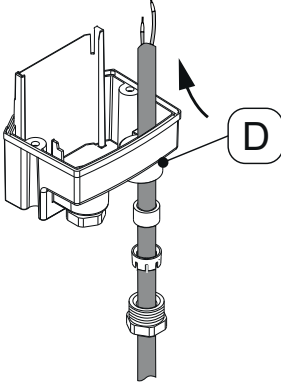
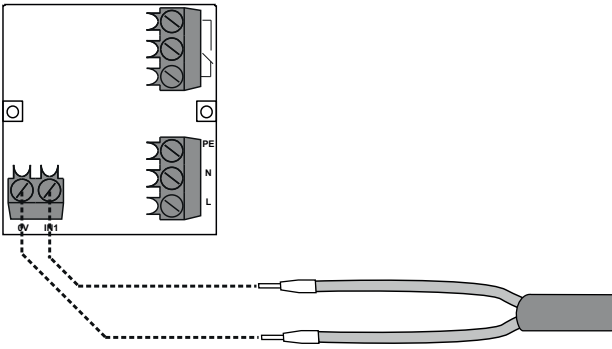
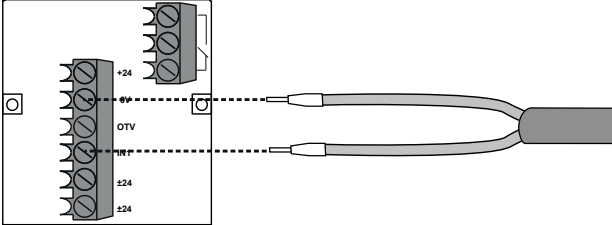
7.1.2 Connecting the dry contact

The product has a dry contact on the power control board. It can be used to display a fault message at a remote maintenance centre.

Illustration	Description / explanation
	<ol style="list-style-type: none"> 1. Prepare the power connection cable for the dry contact (depending on the application). <p> If the external TEST button is to be connected in addition to the dry contact, a 4/5-wire cable must be used for the connection (depending on the application).</p>
	<ol style="list-style-type: none"> 2. Use the right-hand cable gland [D] for the connection.
	<p>Power control board AC</p> <ol style="list-style-type: none"> 3. Connect the power connection cable for the dry contact in accordance with the terminal diagram „4.6 Terminal diagrams“ on page 23.
	<p>Power control board DC</p> <ol style="list-style-type: none"> 4. Connect the power connection cable for the dry contact in accordance with the terminal diagram „4.6 Terminal diagrams“ on page 23.



7.1.3 Connection of external TEST button

The product supports the connection of an external TEST button. This makes it possible for condensate to be discharged via remote control. If the external contact is closed, the solenoid valve opens in the same way as when the TEST button is pressed on the top cover, causing the product to discharge condensate.

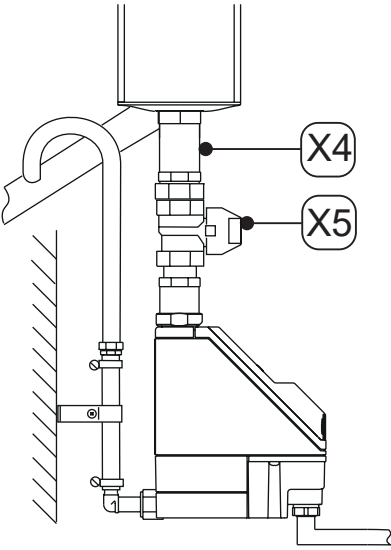
Illustration	Description / explanation
	<ol style="list-style-type: none"> 1. Prepare the connection cable for the external TEST button (depending on the application). <p> If the dry contact is to be connected in addition to the external TEST button, a 4/5-wire cable must be used for the connection (depending on the application).</p>
	<ol style="list-style-type: none"> 2. Use the right-hand cable gland [D] for the connection.
	<p>Power control board AC</p> <ol style="list-style-type: none"> 3. Connect the power connection cable for the dry contact in accordance with the terminal diagram „4.6 Terminal diagrams“ on page 23.
	<p>Power control board DC</p> <ol style="list-style-type: none"> 4. Connect the power connection cable for the dry contact in accordance with the terminal diagram „4.6 Terminal diagrams“ on page 23.

8. Start-up procedure

8.1 Warning notices

Personnel	
Skilled technical personnel - pressure equipment and systems and skilled technical personnel - electrical (see section „2.3 Target group and personnel“ on page 8)	
DANGER	Sudden escape of pressurised fluids
	<p>There is a danger of death or serious personal injury resulting from contact with fast or suddenly escaping fluids or through bursting system parts.</p> <ul style="list-style-type: none"> • Before pressurisation, check all system connections for leak tightness and tighten if necessary. • Slowly pressurise the system.
DANGER	Electric voltage
	<p>Contact with live electrical components may result in death, serious injury, malfunction, device failure, or material damage.</p> <ul style="list-style-type: none"> • Only operate the product and accessories with the cover complete and closed, the electronics housing closed, or the switch cabinet closed. • Check the product and accessories before start-up in accordance with the locally applicable legal requirements and regulations.


8.2 Start-up steps

Illustration	Description / explanation
	<ol style="list-style-type: none"> 1. Connect the power supply. 2. Slowly pressurise the system section (e.g., by slowly opening the recommended shut-off valve [X5] in the condensate inlet line [X4]). 3. Carry out a functional test (see section „10.3.2 Functional test“ on page 49).

9. Operation

9.1 Warning notices

Personnel	
Operating personnel (see section „2.3 Target group and personnel“ on page 8)	

DANGER	Electric voltage
	Contact with live electrical components may result in serious personal injury or death. <ul style="list-style-type: none"> • Only operate the product and accessories with the cover complete and closed, the electronics housing closed, or the switch cabinet closed.

9.2 Operating states

9.2.1 BEKOMAT® 20 Vario

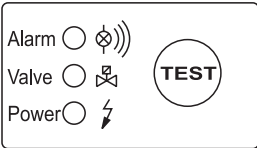
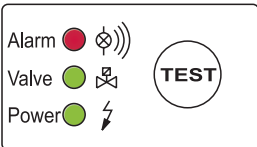
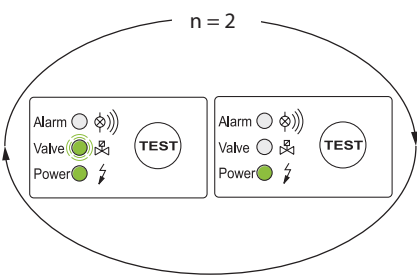
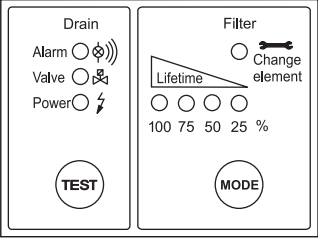
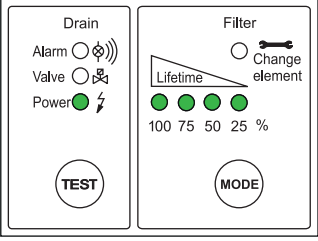
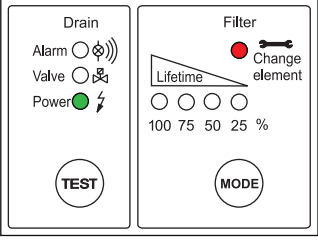
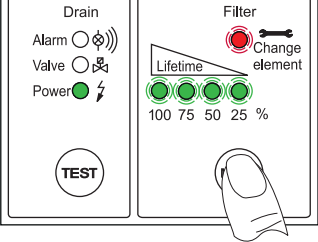
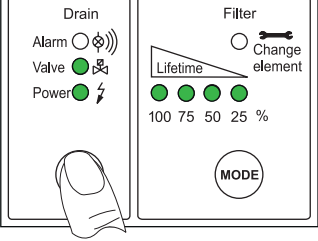
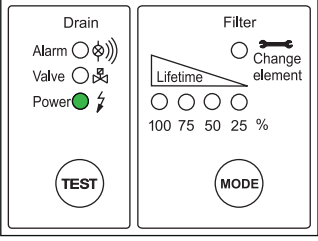
Illustration	Description / explanation
	<p>Disconnected</p> <ul style="list-style-type: none"> • All LEDs are off
	<p>Switch on / power-on self-test</p> <ul style="list-style-type: none"> • All LEDs light up for 1 second
	<p>Positive power-on self-test (repeat 2x)</p> <ul style="list-style-type: none"> • The red Alarm LED is off • The green Valve LED lights up during the solenoid valve cycles • The green Power LED is on • The solenoid valve cycles <p>→ goes into normal operation</p>

Illustration	Description / explanation
	<p>Negative power-on self-test (repeat 20x)</p> <ul style="list-style-type: none"> The red Alarm LED is on The green Valve LED lights up during the solenoid valve cycles The green Power LED is on The solenoid valve cycles <p>→ Goes to fail-safe operation (continuous loop)</p> <ul style="list-style-type: none"> The solenoid valve is cycling once per second
	<p>Ready for operation (normal operating mode)</p> <ul style="list-style-type: none"> The red Alarm LED is off The green Valve LED is off The green Power LED is on
	<p>Discharge procedure (TEST button pressed briefly)</p> <ul style="list-style-type: none"> The red Alarm LED is off The green Valve LED lights up during the discharge procedure The green Power LED is on
	<p>Pre-alarm (TEST button pressed > 1 min and < 5 min)</p> <ul style="list-style-type: none"> The red Alarm LED flashes The green Valve LED is on The green Power LED is on
	<p>Alarm (TEST button pressed > 5 min)</p> <ul style="list-style-type: none"> The red Alarm LED is on The green Valve LED is off The green Power LED is on
	<p>Alarm mode (malfunctioning of condensate drain)</p> <ul style="list-style-type: none"> The red Alarm LED flashes The green Power LED lights up The green Valve LED lights up during the solenoid valve cycles The solenoid valve is cycling every 4 minutes <p>→ Passes to normal mode with free condensate drain</p>

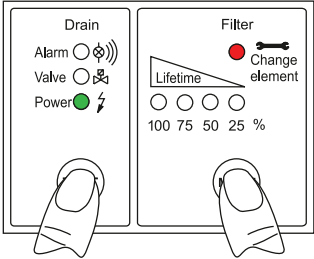
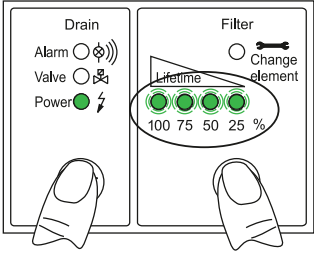
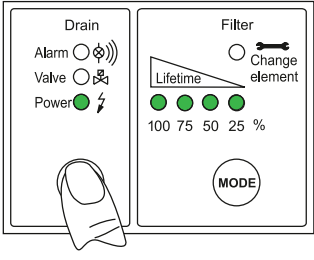
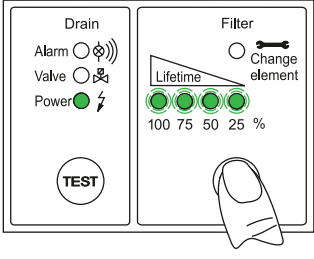
9.2.2 BEKOMAT® 20 Vario FM

Illustration	Description / explanation
	<p>Disconnected</p> <ul style="list-style-type: none"> All LEDs are off.
	<p>Ready for operation (normal operating mode)</p> <ul style="list-style-type: none"> The green Power LED is lit. All 4 green Lifetime LEDs are lit. 100% to 76% service life available. At 75% to 51% only 3 LEDs are lit. At 50% to 26% only 2 LEDs are lit. At 25% to 1% only 1 LED is lit.
	<p>Filter change</p> <ul style="list-style-type: none"> The green Power LED is lit. The red Change Element LED is lit.
	<p>LED function check</p> <ul style="list-style-type: none"> Press and hold the MODE button. <ul style="list-style-type: none"> → The green Power LED is lit. → All green Lifetime LEDs flash. → The Change Element LED flashes.
	<p>Discharge procedure (TEST button pressed briefly)</p> <ul style="list-style-type: none"> The red Alarm LED is off. The green Valve LED is lit during the discharge procedure. The green Power LED is on.
	<p>Operating voltage / operating function</p> <ul style="list-style-type: none"> The green Power LED is lit. <p>Operating voltage, valve function and alarm are shown in the left-hand "Drain" field.</p>

For further information about fault indications during operation, see „15. Troubleshooting“ on page 57.




9.2.2.1 Filter management function reset

After filter replacement, the filter management function must be reset. To reset, carry out the following steps after filter replacement.

Illustration	Description / explanation
	<p>Starting the reset function</p> <ul style="list-style-type: none"> To start the reset mechanism, press the TEST button and the MODE button at the same time. <p>The action of the button pressed first starts. When the second button is pressed as well, the first action triggered is stopped.</p>
	<p>Reset mechanism</p> <ul style="list-style-type: none"> Keep both buttons pressed for longer than 10 seconds. → All Lifetime LEDs start to flash. The standard BEKOMAT® functionality is active in the background. If no button is pressed, it remains in this state. Release both buttons.
	<p>Cancelling the reset mechanism</p> <ul style="list-style-type: none"> Press the TEST button briefly. → The reset mechanism is cancelled immediately. Do not press any button. → The reset mechanism cancels automatically after 60 seconds.
	<p>Reset filter lifetime to the initial value</p> <ul style="list-style-type: none"> Press the MODE button. → The filter lifetime counter is reset to the initial value. → The BEKOMAT® returns to its normal operating state.

10. Maintenance

10.1 Warning notices

Personnel	
Skilled technical personnel - product servicing (see section „2.3 Target group and personnel“ on page 8)	
DANGER	Sudden escape of pressurised fluids
	<p>There is a danger of death or serious personal injury resulting from contact with fast or suddenly escaping fluids or through bursting system parts.</p> <ul style="list-style-type: none"> • Before starting work, depressurise the pressurised system and secure it against unintentional pressurisation.
DANGER	Electric voltage
	<p>Contact with live electrical components may result in serious personal injury or death.</p> <ul style="list-style-type: none"> • Only carry out maintenance and repair work on the product when it has been isolated from the power source and locked and tagged out. • Conduct electrical installation work in compliance with all locally applicable legal requirements and regulations.
WARNING	Ingress of moisture or foreign bodies
	<p>Removing components or opening the product may allow water or foreign bodies to enter the opened product. This can lead to accidents, personal injury and damage to property as well as impairments in operation.</p> <ul style="list-style-type: none"> • Protect the product from splashing water or moisture. • Only open the product or remove components in a dry place. • Do not insert any foreign bodies into the openings of the product. • Keep all contact surfaces and openings free of dirt and moisture. • Do not clean using pressure washers or steam cleaners.


10.2 Maintenance schedule

Maintenance	Interval
Wear part replacement	After 8760 operating hours or 1 million switching cycles*; at least annually
Cleaning	Annually
Visual inspection	Weekly
Leakage test	After all installation, maintenance and servicing work on the product

* based on 7 bar(g) (101.5 psi(g)) and pH-neutral condensate

10.3 Maintenance work

For installation work to be carried out, the following prerequisites must be fulfilled and the preparatory tasks must have been completed.

Prerequisites		
Tools	Material	Protective equipment
<ul style="list-style-type: none"> Screwdriver – flat head size 2.5 mm (0.09 in) Combination wrench or adjustable wrench 	<ul style="list-style-type: none"> Sealants Suitable lubricant for greasing the O-rings Mild cleaning agent Cotton or disposable cloth 	<p>Always to be worn:</p> 

Preparatory tasks	
1.	The product has been fully shut down (see „12. Shut-down procedure“ on page 52).
2.	The product has been dismantled (see section „13. Dismounting procedure“ on page 53).

10.3.1 Wear part replacement

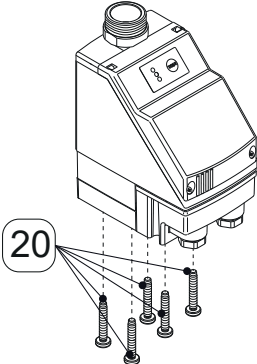
Illustration	Description / explanation
	<ol style="list-style-type: none"> Loosen the screws [20].

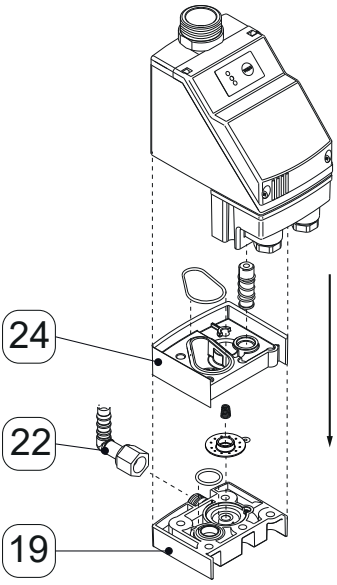
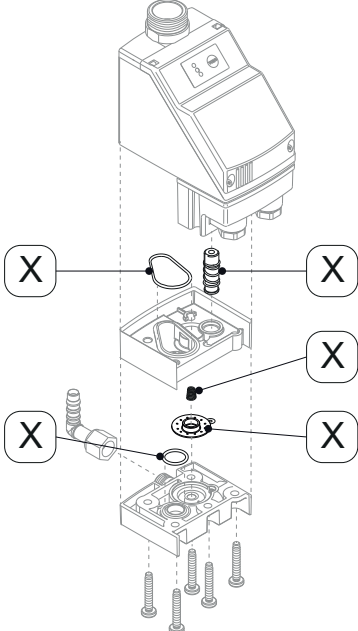
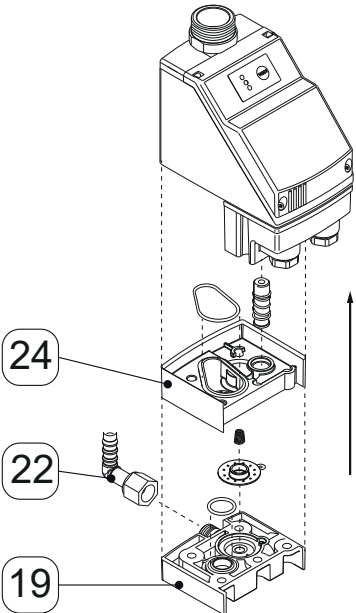
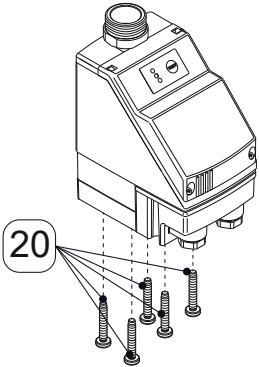
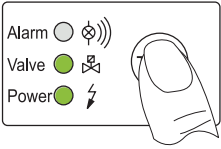
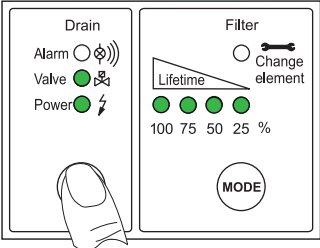
Illustration	Description / explanation
	<ol style="list-style-type: none"><li data-bbox="821 488 1260 521">2. Remove the elbow connector [22].<li data-bbox="821 560 1428 622">3. Carefully remove the membrane seat [19] and the membrane cap [24].
	<ol style="list-style-type: none"><li data-bbox="821 1160 1364 1223">4. Replace all the components in the set of wear parts [X].<li data-bbox="821 1261 1340 1294">5. Grease the O-rings in the set of wear parts.

Illustration	Description / explanation
	<ol style="list-style-type: none"> 6. Bring the membrane seat [19] and the membrane cap [24] together as shown. 7. Mount the elbow connector [22].
	<ol style="list-style-type: none"> 8. Insert and tighten the screws [20].

Final steps

1.	Install the product (see section „6. Installation procedure“ on page 25).
2.	Start the product up (see section „8. Start-up procedure“ on page 40).

10.3.2 Functional test

Illustration	Description / explanation
	<p>Press the TEST button for 2 ... 5 seconds.</p> <ul style="list-style-type: none"> → The valve opens and condensate is drained
	<p>Press the TEST button for 2 ... 5 seconds.</p> <ul style="list-style-type: none"> → The green POWER LED lights up → The green Valve LED is lit during the discharge procedure. → The valve opens and condensate is drained



10.3.3 Visual inspection

During the visual inspection of the product, inspect all components for mechanical damage and corrosion. Replace damaged components immediately.

10.3.4 Leakage test

The leakage test is a non-destructive test method and is used to prove leak tightness in vacuum and overpressure systems. The leakage test can be carried out in different ways. The manufacturer does not recommend any specific method over another. The selection and determination of the test procedure is the responsibility of the company operating the pressurised system and must be carried out in conformity with the applicable standards and guidelines (e.g., DIN EN 1779).

10.3.5 Cleaning

CAUTION	Personal injury through inappropriate use of cleaning media
	<p>Inappropriate use of cleaning media may result in minor injuries and damage to health.</p> <ul style="list-style-type: none"> • Never clean the device with a dripping wet cloth. • Do not clean using pressure washers. • Never use abrasive or aggressive cleaning agent or solvents which could damage the outer coating (e.g. markings, type plate, corrosion protection, etc.). • Never clean the device with hard or pointed implements. • Use an anti-static, damp cloth for cleaning the outside. • Immediately replace any product markings (pictograms, markings) that have become illegible. • Use personal protective equipment. • Use cleaning media in accordance with the manufacturer's instructions.
NOTE	Observe local hygiene regulations
	In addition to the cleaning instructions listed, any regionally applicable or company-specific hygiene regulations must be observed.

Preparatory tasks

1.	The product has been fully shut down.
----	---------------------------------------

Cleaning work

1.	Spray mild cleaning agent onto a cotton cloth or disposable tissue until it is damp (not wet).
2.	Rub the surfaces of the product with the damp cloth.
3.	Start the product up.

Final steps

1.	Assemble the product.
2.	Install the product (see „6. Installation procedure“ on page 25).
3.	Start the product up (see „8. Start-up procedure“ on page 40).

11. Consumables, accessories and spare parts

11.1 Order information

Manufacturer customer service requires the following data for an enquiry or order:

- Serial number (see type plate)
- Material number and designation of the accessory or spare part
- Required quantity of accessories or spare parts to be delivered

The contact data for the relevant manufacturer customer services are listed in section „1.1 Contact“ on page 5.

11.2 Accessories



Description	Material no.
Trace heater 230 VAC	4041657
Drain kit	2000045

11.3 Spare parts and set of seals

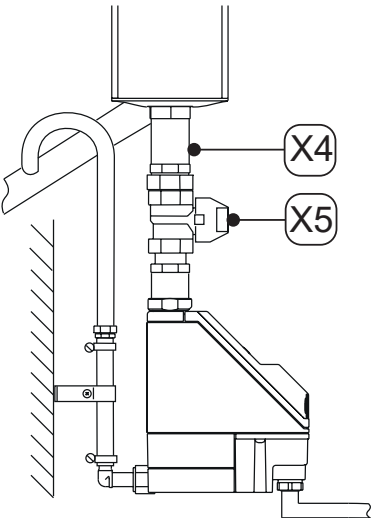










Description	Material no.
Set of wear parts	4003701
Membrane seat	4003700
5 x membrane	2000496
3 x elbow connector	4003702
Control circuit board BEKOMAT® 20 Vario	4047964
Control circuit board BEKOMAT® 20 Vario FM	4060203
Power control board 230 VAC	2001501
Power control board 115 VAC	2001502
Power control board 24 VAC	2001504
Power control board 24 VDC	2001915

12. Shut-down procedure

12.1 Warning notices

Personnel	
Skilled technical personnel - product servicing (see section „2.3 Target group and personnel“ on page 8)	
DANGER	Sudden escape of pressurised fluids
	<p>There is a danger of death or serious personal injury resulting from contact with fast or suddenly escaping fluids or through bursting system parts.</p> <ul style="list-style-type: none"> • Set up a safety area around the working area before starting work. • Before starting work, depressurise the pressurised system and secure it against unintentional pressurisation.
DANGER	Electric voltage
	<p>Contact with live electrical components may result in death, serious injury, malfunction, device failure, or material damage.</p> <ul style="list-style-type: none"> • Set up a safety area around the working area before starting work. • Before starting work, isolate the product and accessories from the power source and secure them against being switched back on again unintentionally.

12.2 Shut-down steps



Illustration	Description / explanation
	<ol style="list-style-type: none"> 1. Stop condensate feed via the condensate inlet line [X4] (e.g. by closing the recommended shut-off valve [X5]).
<div style="display: flex; justify-content: space-around;"> <div style="border: 1px solid black; padding: 5px;"> <p>Alarm </p> <p>Valve </p> <p>Power </p> </div> <div style="border: 1px solid black; padding: 5px;"> <p>Drain </p> <p>Alarm </p> <p>Valve </p> <p>Power </p> </div> <div style="border: 1px solid black; padding: 5px;"> <p>Filter </p> <p>Change element </p> <p>Lifetime </p> <p>100 75 50 25 %</p> <p style="text-align: center;">MODE</p> </div> </div>	<ol style="list-style-type: none"> 2. Press the TEST button briefly multiple times. <ul style="list-style-type: none"> → The BEKOMAT® is depressurised → The condensate remaining in the BEKOMAT® is drained 3. Disconnect the BEKOMAT® from the power supply and switch off all power.

13. Dismounting procedure

13.1 Warning notices


Personnel

4. Skilled technical personnel - product servicing (see section „2.3 Target group and personnel“ on page 8)

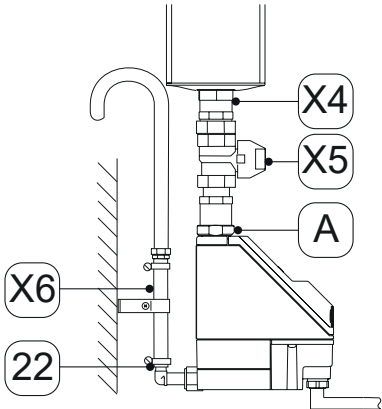
DANGER	Sudden escape of pressurised fluids
	<p>There is a danger of death or serious personal injury resulting from contact with fast or suddenly escaping fluids or through bursting system parts.</p> <ul style="list-style-type: none"> • Set up a safety area around the working area before starting work. • Before starting work, depressurise the pressurised system and secure it against unintentional pressurisation.
DANGER	Electric voltage
	<p>Contact with live electrical components may result in death, serious injury, malfunction, device failure, or material damage.</p> <ul style="list-style-type: none"> • Set up a safety area around the working area before starting work. • Before starting work, isolate the product and accessories from the power source and secure them against being switched back on again unintentionally.

13.2 Dismounting steps

For dismounting work to be carried out, the following prerequisites must be fulfilled and the preparatory tasks must have been completed.

Prerequisites		
Tools	Material	Protective equipment
<ul style="list-style-type: none"> Combination wrench or adjustable wrench 	<ul style="list-style-type: none"> No material necessary 	Always to be worn: 



Preparatory tasks	
1.	The product has been fully shut down (see section „12. Shut-down procedure“ on page 52).
2.	Depressurise the pressurised system or the respective system section and secure it against unintentional pressurisation.

Illustration	Description / explanation
	<ol style="list-style-type: none"> Remove the hose [X6] from the elbow connector [22]. Loosen and remove the condensate inlet line [X4] and the recommended shut-off valve [X5] from the condensate inlet [A]. Disconnect all electrical connections.

14. Disposal

At the end of their useful life the product and the accessories must be disposed of appropriately, e.g. by a specialist disposal company. Materials such as glass, plastics and some chemical compounds are mostly recoverable, reusable or recyclable.

14.1 Warning notices

NOTE	Inappropriate disposal
	<p>Inappropriate disposal of parts, components, operating and auxiliary materials as well as cleaning media can cause environmental damage.</p> <ul style="list-style-type: none"> • Dispose of all components, parts, operating and auxiliary materials as well as cleaning agents professionally and in accordance with all locally applicable legal requirements and regulations. • Dispose of electrical and electronic components using a specialist disposal company or return them to manufacturer. • In case of doubt, consult a local disposal company before disposal.
INFORMATION	Disposal of electrical and electronic equipment
	<p>Electrical and electronic equipment (EEE) contains materials, components and substances which can be dangerous and harmful to human health and the environment if the waste from electrical and electronic equipment (WEEE) is not disposed of properly.</p> <p>Electrical and electronic equipment is marked with a crossed-out rubbish bin symbol. The crossed-out rubbish bin symbol indicates that electrical and electronic equipment must be collected separately and must not be disposed of together with unsorted household waste.</p> <p>For additional information regarding locally applicable legal requirements and regulations concerning recycling electrical and electronic products, contact your local disposal companies or the responsible municipal authority.</p>

14.2 Disposal of operating and auxiliary materials

Operating material / auxiliary material	EU waste code
Adsorption materials, filter materials, cleaning wipes and protective clothing – contaminated by oils or other hazardous substances	15 02 02
Adsorption materials, filter materials, cleaning wipes and protective clothing - with the exception of those classified by 15 02 02	15 02 03
Packaging - paper and cardboard	15 01 01
Packaging - plastic material	15 01 02
Waste oil - mineral	13 02 05
Waste oil - synthetic	13 02 06

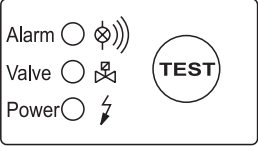
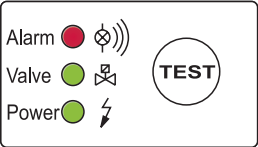
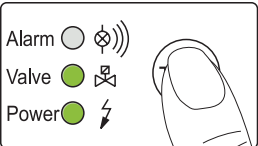
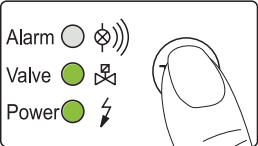
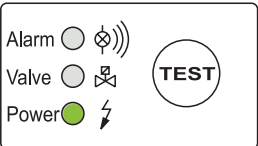
14.3 Disposal of components

Ensure the following prerequisites are met before disposal:

Prerequisites	
1.	The product and the accessories have been shut down and dismantled.
2.	The product and the accessories have been cleaned and any fluid residue has been removed from them.


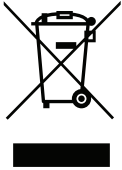

Components	EU waste code
Electric and electronic devices with the exception of those covered by 20 01 21, 20 01 23 and 20 01 35	20 01 36
Plastic material	20 01 39
Metals	20 01 40

15. Troubleshooting

Illustration	Description / explanation	Corrective action
	<p>No LED is lit.</p>	<ul style="list-style-type: none"> • Check that the voltage is as per the rated operating voltage on the type plate. • Check whether the terminals of the power control board (L, N, PE) have voltage. • Check the plug-type connection between the power control board and the control circuit board.
	<p>All LEDs are permanently lit.</p>	<ul style="list-style-type: none"> • Isolate the device from operating voltage and reconnect after > 5 seconds. • Inspect circuit board for damage.
	<p>TEST button has been pressed but no condensate is being discharged.</p>	<ul style="list-style-type: none"> • Check inlet and drain lines. • Replace wear parts. • Check whether valve actuation can be heard by pressing the TEST button several times. • Check the plug connections of the terminal block on the control circuit board.
	<p>Condensate is only discharged when the TEST button is pressed.</p>	<ul style="list-style-type: none"> • Install inlet line with a downward gradient > 3%. • Clean sensor tube. • Check whether the necessary minimum pressure has been reached.
	<p>Device blows off air continuously.</p>	<ul style="list-style-type: none"> • Clean entire valve unit. • Replace wear parts. • Clean sensor tube.

16. Appendices

16.1 Approval certificates and declarations of conformity

Symbol	Description / explanation
	<p>CE marking</p> <p>The CE marking indicates that a product fulfils all the EU regulations applicable to the product and that all basic safety and health requirements were met during its production. The product may be sold on the European market.</p>
	<p>WEEE marking</p> <p>The crossed out rubbish bin marks an electrical or electronic product that must not be disposed of with domestic waste at the end of its service life. Free collecting points for used electrical equipment as well as further acceptance points for reuse of the products are available for them to be returned. Addresses can be obtained from the local authorities.</p>
	<p>UKCA marking</p> <p>The UKCA marking is a conformity mark that indicates conformity with the applicable requirements for products sold within Great Britain.</p>

17. Declaration of Conformity

BEKO TECHNOLOGIES GMBH
Im Taubental 7
41468 Neuss

GERMANY

Tel: +49 2131 988-0
www.beko-technologies.com



EU-Konformitätserklärung

Wir erklären hiermit, dass das nachfolgend bezeichnete Produkt den Anforderungen der einschlägigen Richtlinien und technischen Normen entspricht. Diese Erklärung bezieht sich nur auf das Produkt in dem Zustand, in dem das Produkt in Verkehr gebracht wurde. Nicht vom Hersteller angebrachte Teile und/oder nachträglich vorgenommene Eingriffe bleiben unberücksichtigt.

Produktbezeichnung:	Kondensatableiter
Modelle:	BEKOMAT® 20, 20 FM, 20 V, 20 VFM
Spannungsvarianten:	24 VDC, 24 VAC, 100 VAC, 115 VAC, 200 VAC, 230 VAC
Max. Betriebsdruck:	16 bar(ü)
Produktbeschreibung und Funktion:	Kondensatableiter zur elektronisch niveaugeregelten Ableitung von Kondensat im Druckluftnetz.

Niederspannungs-Richtlinie 2014/35/EU

Angewandte harmonisierte Normen: EN 61010-1: 2010/A1:2019/AC:2019-04

Die Geräte mit einer Betriebsspannung von 24 ... 48 VAC und 18 ... 72 VDC fallen nicht in den Anwendungsbereich der Niederspannungs-Richtlinie.

EMV-Richtlinie 2014/30/EU

Angewandte harmonisierte Normen: EN 61326-1:2013

ROHS II-Richtlinie 2011/65/EU

Die Vorschriften der Richtlinie 2011/65/EU zur Beschränkung der Verwendung bestimmter gefährlicher Stoffe in Elektro- und Elektronikgeräten werden erfüllt.

Der Hersteller trägt die alleinige Verantwortung für die Ausstellung dieser Konformitätserklärung.

Neuss, 21.12.2021

Unterzeichnet für und im Namen von:

BEKO TECHNOLOGIES GMBH

i.V. Christian Riedel

Leiter Qualitätsmanagement International

BEKO TECHNOLOGIES GMBH
Im Taubental 7
41468 Neuss

GERMANY

Phone: +49 2131 988-0
www.beko-technologies.com



EU Declaration of Conformity

We hereby declare that the product named below complies with the stipulations of the relevant directives and technical standards. This declaration only refers to the product in the condition in which it has been placed into circulation by us. Parts which have not been installed by the manufacturer and/or modifications which have been implemented subsequently remain unconsidered.

Product designation:	Condensate drain
Models:	BEKOMAT® 20, 20 FM, 20 V, 20 VFM
Voltage versions:	24 VDC, 24 VAC, 100 VAC, 115 VAC, 200 VAC, 230 VAC
Max. operating pressure:	16 bar(g)
Product description and function:	Condensate drain for electronically level-controlled discharge of condensate in the compressed-air system.

Low Voltage Directive 2014/35/EU

Applied harmonised standards: EN 61010-1: 2010/ A1:2019/ AC:2019-04

The devices with a working voltage of 24... 48 VAC and 18... 72 VDC are not governed by the scope of the Low Voltage Directive.

EMC Directive 2014/30/EU

Applied harmonised standards: EN 61326-1:2013

RoHS II Directive 2011/65/EU

The products meet the requirements laid down in European Directive 2011/65/EU concerning the restriction on the use of certain hazardous substances in electrical and electronic devices.

The manufacturer shall have sole responsibility for issuing this declaration of conformity.

Signed for and on behalf of:

Neuss, 21 December 2021

BEKO TECHNOLOGIES GMBH

i.V. Christian Riedel
Head of International Quality Management

BEKO TECHNOLOGIES GMBH
Im Taubental 7
41468 Neuss

GERMANY

Phone: +49 2131 988-0
www.beko-technologies.com



UK Declaration of Conformity

We hereby declare that the product named below complies with the stipulations of the relevant directives and technical standards. This declaration applies only to the product in the condition in which it is marketed by us. Parts which have not been installed by the manufacturer and/or modifications which have been implemented subsequently remain unconsidered.

Product designation:	Condensate drain
Types:	BEKOMAT® 20, 20 FM, 20 V, 20 VFM
Supply voltage versions:	24 VDC, 24 VAC, 48 VAC, 100 VAC, 115 VAC, 200 VAC, 230 VAC
Max. operating pressure:	16 bar(g)
Product description and function:	Condensate drain for electronically level-controlled discharge of condensate in the compressed-air system.

Manufacturer: **BEKO TECHNOLOGIES GMBH**
Im Taubental 7, 41468 Neuss, Germany

UK Representative: **BEKO TECHNOLOGIES Ltd**
Unit 11-12 Moons Park, Burnt Meadow Road, North Moons Moat
Redditch, Worcs, B98 9PA, United Kingdom

Electrical Equipment (Safety) Regulations 2016, 2016 No. 1101
Applied standards: S.I. 2016 No. 1101
(EN 61010-1:2010/A1:2019/AC:2019-04)

The devices with a working voltage of 24 ... 48 VAC and 18 ... 72 VDC are not governed by the scope of the Low Voltage Directive.

Electromagnetic Compatibility Regulations 2016, 2016 No. 1091
Applied standards: S.I. 2016 No. 1091
(EN 61326-1:2013)

RoHS Regulations 2012 No 3032 (2011/65/EU)
The products meet the requirements laid down in RoHS Regulations 2012 concerning the restriction of the use of certain hazardous substances in electrical and electronic devices.

The products bear the UKCA mark:



BEKO TECHNOLOGIES GMBH shall have sole responsibility for issuing this Declaration of Conformity.

Neuss, 21.12.2021

Signed for and on behalf of:
BEKO TECHNOLOGIES GMBH

i.V. Christian Riedel
Head of Quality Management International

UK_decl_BM20_20FM_en_12_2021

BEKO TECHNOLOGIES GmbH

Im Taubental 7
 D - 41468 Neuss
 Tel. +49 2131 988 0
 Fax +49 2131 988 900
 info@beko-technologies.com
 service-eu@beko-technologies.com

DE**BEKO TECHNOLOGIES LTD.**

Unit 11-12 Moons Park
 Burnt Meadow Road
 North Moons Moat
 Redditch, Worcs, B98 9PA
 Tel. +44 1527 575 778
 info@beko-technologies.co.uk

GB**BEKO TECHNOLOGIES S.à.r.l.**

Zone Industrielle
 1 Rue des Frères Rémy
 F - 57200 Sarreguemines
 Tél. +33 387 283 800
 info@beko-technologies.fr
 service@beko-technologies.fr

FR**BEKO TECHNOLOGIES B.V.**

Veenen 12
 NL - 4703 RB Roosendaal
 Tel. +31 165 320 300
 benelux@beko-technologies.com
 service-bnl@beko-technologies.com

NL**BEKO TECHNOLOGIES
(Shanghai) Co. Ltd.**

Rm.715 Building C, VANTONE Center
 No.333 Suhong Rd.Minhang District
 201106 Shanghai
 Tel. +86 (21) 50815885
 info.cn@beko-technologies.cn
 service1@beko.cn

CN**BEKO TECHNOLOGIES s.r.o.**

Na Pankraci 58
 CZ - 140 00 Praha 4
 Tel. +420 24 14 14 717 /
 +420 24 14 09 333
 info@beko-technologies.cz

CZ**BEKO Tecnológica España S.L.**

Torruella i Urpina 37-42, nave 6
 E - 08758 Cervelló
 Tel. +34 93 632 76 68
 Mobil +34 610 780 639
 info.es@beko-technologies.es

ES**BEKO TECHNOLOGIES LIMITED**

Room 2608B, Skyline Tower,
 No. 39 Wang Kwong Road
 Kwoloon Bay Kwoloon, Hong Kong
 Tel. +852 2321 0192
 Raymond.Low@beko-technologies.com

HK**BEKO TECHNOLOGIES INDIA Pvt. Ltd.**

Plot No.43/1 CIEEP Gandhi Nagar
 Balanagar Hyderabad
 IN - 500 037
 Tel. +91 40 23080275 /
 +91 40 23081107
 Madhusudan.Masur@bekoindia.com
 service@bekoindia.com

IN**BEKO TECHNOLOGIES S.r.l**

Via Peano 86/88
 I - 10040 Leinì (TO)
 Tel. +39 011 4500 576
 Fax +39 0114 500 578
 info.it@beko-technologies.com
 service.it@beko-technologies.com

IT**BEKO TECHNOLOGIES K.K**

KEIHIN THINK Building 8 Floor
 1-1 Minamiwatarida-machi
 Kawasaki-ku, Kawasaki-shi
 JP - 210-0855
 Tel. +81 44 328 76 01
 info@beko-technologies.jp

JP**BEKO TECHNOLOGIES Sp. z o.o.**

ul. Pańska 73
 PL - 00-834 Warszawa
 Tel. +48 22 314 75 40
 info.pl@beko-technologies.pl

PL**BEKO TECHNOLOGIES S. de R.L. de C.**

BEKO Technologies, S de R.L. de C.V.
 Blvd. Vito Alessio Robles 4602 Bodega 10
 Zona Industrial
 Saltillo, Coahuila, 25107
 Mexico
 Tel. +52(844) 218-1979
 informacion@beko-technologies.com

MX**BEKO TECHNOLOGIES, CORP.**

900 Great Southwest Pkwy SW
 Atlanta, GA 30336
 USA
 Tel. +1 404 924-6900
 beko@bekousa.com

US